



# Tools for the Mechanical Mounting and Dismounting of Rolling Bearings

Technical Product Information



# Contents

1	Mechanical mounting and dismounting of rolling bearings .....	4
1.1	Cylindrical bearing seats .....	4
1.2	Tapered bearing seats .....	5
1.3	Schaeffler Mounting Manager .....	6
2	Tools for mounting.....	7
2.1	Mounting sleeve set TOOL-IMPACT .....	7
2.1.1	Fitting tool set IMPACT-33.....	8
2.1.2	Mounting sleeve set IMPACT-39.....	9
3	Tools for mounting and dismounting.....	10
3.1	Sockets LOCKNUT-SOCKET .....	10
3.2	Hook wrenches LOCKNUT-HOOK.....	12
4	Tools for dismounting.....	14
4.1	Mechanical pullers.....	14
4.1.1	Two-/three-arm pullers MSP-2/3 .....	15
4.2	Hydraulic pullers.....	17
4.2.1	Two-/three-arm pullers HP .....	18
4.2.2	Two-/three-arm pullers HSP .....	21
4.2.3	Two-/three-arm pullers HXP .....	24
4.2.4	Three-arm pullers TRI-SECTION-SET .....	27
4.3	Accessories .....	30
4.3.1	Hydraulic pump AHP.....	30
4.3.2	Three-section extraction plates TRI-SECTION-PLATE .....	32
4.3.3	Extraction plate set ACC-SET .....	35
5	Accessories .....	38
5.1	Transport and mounting tool BEARING-MATE .....	38
6	Service and replacement parts .....	41

# 1 Mechanical mounting and dismounting of rolling bearings

## 1.1 Cylindrical bearing seats

In order to prevent bearing damage, the mounting forces must be applied to the tightly fitted ring during mounting and dismounting. If the extraction forces are directed through the rolling elements during extraction of rolling bearings, the bearings are rendered unusable.

### 1.1.1 Mounting

Smaller bearings can be driven cold onto the shaft or into the housing for normal tight fits.

For the economical and secure mounting of rolling bearings in the range up to 60 mm bore diameter and up to 130 mm outside diameter, mounting tool sets are suitable. They can also be used to easily mount sleeves, intermediate rings, seals and similar components.

Tightly fitted inner rings can be driven onto the shaft or outer rings can be driven into the housing bore by hitting a mounting sleeve with the hammer. Applying the mounting force to the tightly fitted bearing ring prevents the mounting forces from being transmitted through the rolling elements and raceways, which can lead to damage. The precision parts are matched to each other, ensuring that the forces are uniformly transmitted to the end faces of the bearing rings.

1 TOOL-IMPACT



001A1372

### 1.1.2 Dismounting

Extraction tools are used for dismounting. Particular care is necessary during dismounting in order to prevent damage to the bearing. The extraction tool must always be applied to the ring to be removed.

For the dismounting of small rolling bearings up to approx. 100 mm bore diameter that are located with a tight fit on the shaft or in the housing, mechanical pullers are used. The extraction force is normally applied by means of a threaded spindle. In the case of pullers for larger rolling bearings, the work can be aided by means of a hydraulic spindle.

2 Use of the mechanical puller MSP-2/3



001B009D

## 1.2 Tapered bearing seats

The inner ring of a bearing with a tapered bore is always mounted with a tight fit. The bearing can be seated directly on a tapered shaft or be located on a cylindrical shaft using an adapter sleeve or withdrawal sleeve. When the inner ring is pushed on, it is expanded and the radial internal clearance of the bearing is reduced.

The reduction in radial internal clearance is an indication of the seating of the inner ring. In order to prevent bearing damage, the inner ring must not be pushed on too far.

As an alternative to measurement of the radial internal clearance, the axial drive-up distance can also be measured in order to set the radial internal clearance correctly.

Locknuts can be easily tightened and loosened on shafts, adapter sleeves and withdrawal sleeves using sockets. If no tightening torque is specified, hook wrenches are suitable for the tightening and loosening of locknuts and precision locknuts on shafts, adapter sleeves or withdrawal sleeves.

3 Hook wrench

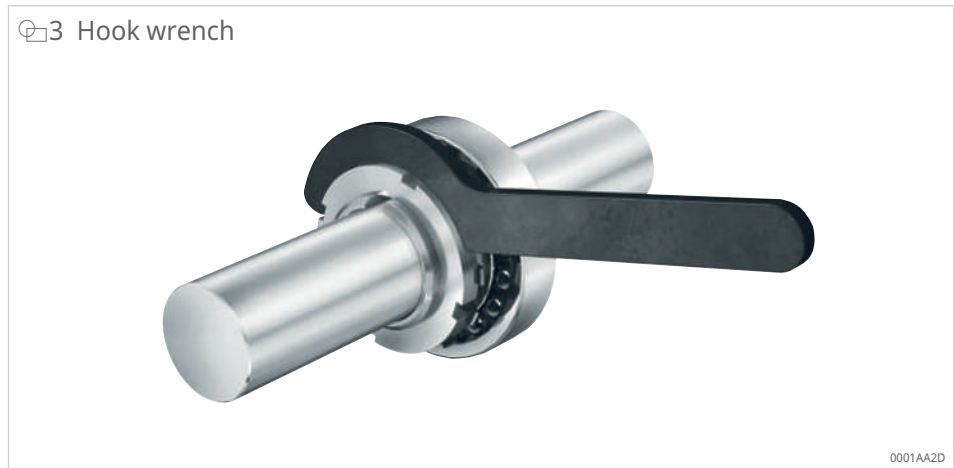

### 1.3 Schaeffler Mounting Manager



The online calculation program Schaeffler Mounting Manager is a user-friendly aid for ensuring the correct mounting of bearings with a tapered bore.

- Shows suitable mounting methods.
- Calculates the values required for mounting in relation to the reduction in radial internal clearance and drive-up distance.
- Provides information about the necessary accessories and tools.

## 2 Tools for mounting

### 2.1 Mounting sleeve set TOOL-IMPACT

For the safe, precise and rapid mounting of bearings and other workpieces with a cylindrical bore.

When an IMPACT mounting set is used, the mounting forces are transmitted directly to the inner ring or outer ring, depending on whether the bearing is being mounted onto a shaft or into the housing, to avoid damage to the bearing.

The impact-resistant plastic collets are made of unbreakable sheet material. This prevents metal/metal contact as well as damage to or premature wear of the bearing seats. The mounting sleeves are made from aluminium. The head of the recoilless hammer produces no sparks.

4 Mounting sleeve set IMPACT-33



The sets can be used for bore diameters from 10 mm to 60 mm. The IMPACT mounting set can also be used for the safe, precise and rapid mounting of other machine components such as pipes, sealing rings, gears and pulleys.

#### Advantages

- Safe, precise and rapid mounting.
- Prevents damage to the bearing, bearing seat and housing.
- The impact-resistant plastic collets are made of unbreakable sheet material.
- The collet numbers are clearly engraved and marked, to avoid mistakes.

#### 1 TOOL-IMPACT overview

Article designation		IMPACT-33	IMPACT-39
Article number		300430469-0000-10	300430477-0000-10
Number of mounting rings		33	39
Mounting ring bore	mm	10...50	10...60
Outside diameter	mm	26...110	26...130
Number of mounting sleeves		3	4
Mounting sleeve bore	mm	18, 32, 52	18, 32, 52, 62
Mass of recoilless hammer	kg	0,7	0,7
Weight	kg	4,8	6,5

## 2.1.1 Fitting tool set IMPACT-33

## 2 Selection of mounting rings

ISO bearing code suffix	Example	Mounting sleeve				Mounting ring
		small	medium	large	extra large	
000	6000	S	-	-	-	10-26
200	2200	S	-	-	-	10-30
300	7300	S	-	-	-	10-35
001	6001	S	-	-	-	12-28
201	3201	S	-	-	-	12-32
301	7301	S	-	-	-	12-37
002	6002	S	-	-	-	15-32
202	2202	S	-	-	-	15-35
302	3302	S	-	-	-	15-42
003	16003	S	-	-	-	17-35
203	7203	S	-	-	-	17-40
303	2303	-	M	-	-	17-47
403	6403	-	M	-	-	20-52
004	7004	-	M	-	-	20-42
204	3204	-	M	-	-	20-47
304	2304	-	M	-	-	20-52
404	6404	-	M	-	-	25-62
005	7005	-	M	-	-	25-52
205	22205	-	M	-	-	25-62
305	3305	-	M	-	-	25-72
405	6405	-	M	-	-	30-72
006	6006	-	M	-	-	30-55
206	NU206	-	M	-	-	30-62
306	7306	-	M	-	-	30-72
406	6406	-	-	L	-	35-80
007	7007	-	-	L	-	35-62
207	22207	-	-	L	-	35-72
307	1307	-	-	L	-	35-80
407	NJ407	-	-	L	-	40-90
008	6008	-	-	L	-	40-68
208	2208	-	-	L	-	40-80
308	7308	-	-	L	-	40-90
408	6408	-	-	L	-	45-100
009	7009	-	-	L	-	45-75
209	6209	-	-	L	-	45-85
309	N309	-	-	L	-	45-100
409	6409	-	-	L	-	50-110
010	6010	-	-	L	-	50-80
210	2210	-	-	L	-	50-90
310	21310	-	-	L	-	50-110



## 2.1.2 Mounting sleeve set IMPACT-39

## 3 Selection of mounting rings

ISO bearing code suffix	Example	Mounting sleeve				Mounting ring
		small	medium	large	extra large	
000	6000	S	-	-	-	10-26
200	2200	S	-	-	-	10-30
300	7300	S	-	-	-	10-35
001	6001	S	-	-	-	12-28
201	3201	S	-	-	-	12-32
301	7301	S	-	-	-	12-37
002	6002	S	-	-	-	15-32
202	2202	S	-	-	-	15-35
302	3302	S	-	-	-	15-42
003	16003	S	-	-	-	17-35
203	7203	S	-	-	-	17-40
303	2303	-	M	-	-	17-47
403	6403	-	M	-	-	20-52
004	7004	-	M	-	-	20-42
204	3204	-	M	-	-	20-47
304	2304	-	M	-	-	20-52
404	6404	-	M	-	-	25-62
005	7005	-	M	-	-	25-52
205	22205	-	M	-	-	25-62
305	3305	-	M	-	-	25-72
405	6405	-	M	-	-	30-72
006	6006	-	M	-	-	30-55
206	NU206	-	M	-	-	30-62
306	7306	-	M	-	-	30-72
406	6406	-	-	L	-	35-80
007	7007	-	-	L	-	35-62
207	22207	-	-	L	-	35-72
307	1307	-	-	L	-	35-80
407	NJ407	-	-	L	-	40-90
008	6008	-	-	L	-	40-68
208	2208	-	-	L	-	40-80
308	7308	-	-	L	-	40-90
408	6408	-	-	L	-	45-100
009	7009	-	-	L	-	45-75
209	6209	-	-	L	-	45-85
309	N309	-	-	L	-	45-100
409	6409	-	-	L	-	50-110
010	6010	-	-	L	-	50-80
210	2210	-	-	L	-	50-90
310	21310	-	-	L	-	50-110
011	6011	-	-	-	XL	55-90
211	20211	-	-	-	XL	55-100
311	3211	-	-	-	XL	55-120
012	6012	-	-	-	XL	60-95
212	2212	-	-	-	XL	60-110
312	3215	-	-	-	XL	60-130

## 3 Tools for mounting and dismounting

### 3.1 Sockets LOCKNUT-SOCKET

The sockets LOCKNUT-SOCKET are suitable for the tightening and loosening of locknuts KM0 to KM20 on shafts, adapter sleeves and withdrawal sleeves.

☞5 Sockets LOCKNUT-SOCKET



00095A70

The sockets require less space on the circumference of the nut than hook wrenches and allow the use of ratchets and torque wrenches.

For safer working, the sockets should be secured using a locking pin and rubber washer. The socket therefore has a hole for the locking pin and a groove for the rubber washer. The rubber washer prevents the locking pin from falling out. The locking pin and rubber washer are included in the scope of delivery.

The sockets LOCKNUT-SOCKET are also suitable, in combination with sockets AMS, for precision locknuts AM.

☞6 Use of the socket LOCKNUT-SOCKET

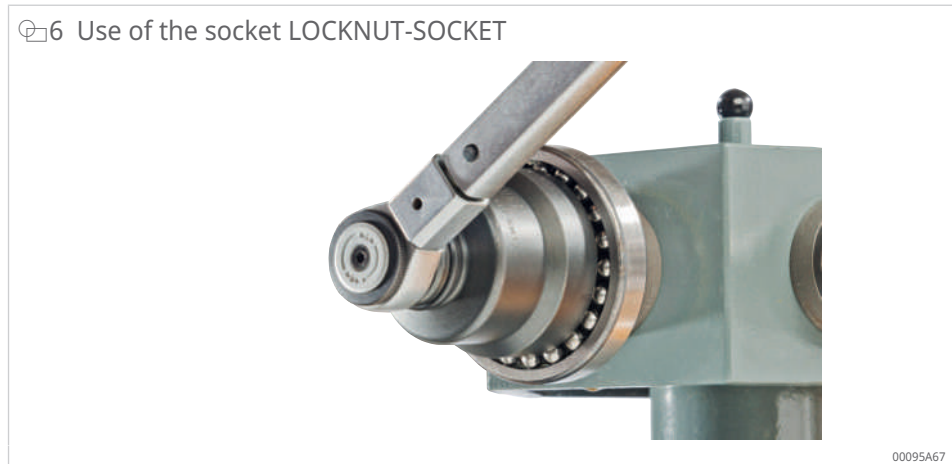

00095A67

The sockets LOCKNUT-SOCKET have a new type of coating. This coating replaces the black oxide coating that was previously used on these components. It has a lustrous silver colour.

The advantages of the coating are as follows:

- It is free from heavy metals and therefore environmentally acceptable.
- It gives improved anti-corrosion protection compared to black oxide coating.

7 LOCKNUT-SOCKET dimensions

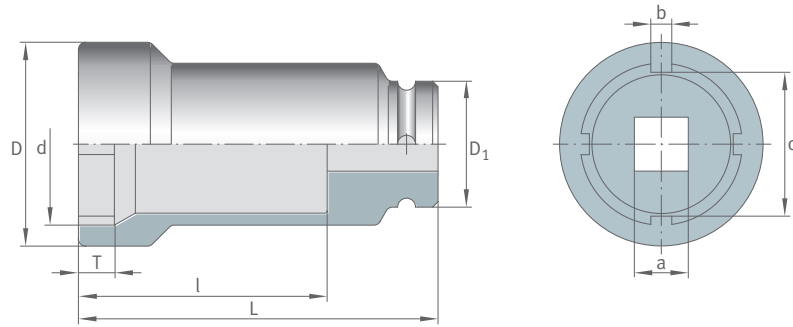

001ACA28

3

## 4 LOCKNUT-SOCKET designs

Designation	Article number	$d$	$D$	$D_1$	$L$	$l$	$T$	$a$	$b$	$c$	$m$	Lock-nuts	Precision locknuts
		mm	mm	mm	mm	mm	mm	mm	inch	mm	mm		
LOCKNUT-SOCKET-KM0	039013618-0000-02	18,3	22	22	57	45	5	$\frac{3}{8}$	2,6	14,4	0,1	KM0	ZM10
LOCKNUT-SOCKET-KM1	039013626-0000-02	22,4	28	22	57	45	5	$\frac{3}{8}$	2,6	18,5	0,1	KM1	ZM12
LOCKNUT-SOCKET-KM2	039013634-0000-02	25,4	33	30	82	65	6	$\frac{1}{2}$	3,5	21,6	0,2	KM2	-
LOCKNUT-SOCKET-KM3	039013642-0000-02	28,4	36	30	82	65	6	$\frac{1}{2}$	3,5	24,6	0,24	KM3	ZM17
LOCKNUT-SOCKET-KM4	039013650-0000-10	32,5	38	30	82	58	9	$\frac{1}{2}$	3,5	28,6	0,28	KM4	ZM20
LOCKNUT-SOCKET-KM5	039013669-0000-10	38,5	46	30	82	58	9	$\frac{1}{2}$	4,7	34,6	0,38	KM5	ZMA20/38, ZM25
LOCKNUT-SOCKET-KM6	039013677-0000-10	45,5	53	30	82	58	9	$\frac{1}{2}$	4,7	41,6	0,42	KM6	ZMA25/45, ZM30
LOCKNUT-SOCKET-KM7	039013685-0000-10	52,5	60	30	82	58	9	$\frac{1}{2}$	4,7	48,6	0,45	KM7	ZMA20/52, ZMA30/52, ZM35
LOCKNUT-SOCKET-KM8	039013693-0000-10	58,6	68	30	82	58	9	$\frac{1}{2}$	5,7	53,8	0,61	KM8	ZMA25/58, ZMA35/58, ZM40
LOCKNUT-SOCKET-KM9	039013707-0000-10	65,7	73,5	44	90	60	13,5	$\frac{3}{4}$	5,7	60,8	0,8	KM9	ZMA30/65, ZM45
LOCKNUT-SOCKET-KM10	039013715-0000-10	70,7	78,5	44	90	60	13,5	$\frac{3}{4}$	5,7	65,8	0,87	KM10	ZMA35/70, ZM50
LOCKNUT-SOCKET-KM11	039013723-0000-10	75,7	83,5	44	90	60	13,5	$\frac{3}{4}$	6,7	69,8	0,9	KM11	ZM55
LOCKNUT-SOCKET-KM12	039013731-0000-10	80,7	88,5	44	90	60	13,5	$\frac{3}{4}$	6,7	74,8	1	KM12	-
LOCKNUT-SOCKET-KM13	039013740-0000-10	85,7	94	44	90	60	13,5	$\frac{3}{4}$	6,7	79,8	1,09	KM13	ZMA45/85, ZM65
LOCKNUT-SOCKET-KM14	039013758-0000-10	92,6	103	62	110	80	12	1	7,6	85,8	2,2	KM14	ZMA50/92, ZM70
LOCKNUT-SOCKET-KM15	039013766-0000-10	98,6	109	62	110	80	13	1	7,6	91,9	2,3	KM15	ZMA55/98, ZMA60/98, ZM75
LOCKNUT-SOCKET-KM16	039013774-0000-10	105,8	116	62	110	80	15	1	7,6	98,9	2,1	KM16	ZMA65/105, ZM80
LOCKNUT-SOCKET-KM17	039013782-0000-10	110,8	121	62	110	80	16	1	7,6	103,9	2,61	KM17	ZMA70/110, ZM85
LOCKNUT-SOCKET-KM18	039013790-0000-10	120,8	131	62	110	80	16	1	9,5	113	2,9	KM18	ZM90
LOCKNUT-SOCKET-KM19	039013804-0000-10	125,8	137	62	110	80	17	1	9,5	118	3,01	KM19	-
LOCKNUT-SOCKET-KM20	039013812-0000-10	130,8	143	62	110	80	18	1	9,5	123	3,3	KM20	ZMA90/130, ZM100
LOCKNUT-SOCKET-KM21	070471665-0000-10	140,8	153	62	110	80	18	1	11,5	131	3,5	KM21	ZMA100/140, ZM105
LOCKNUT-SOCKET-KM22	084750430-0000-10	145,8	158	62	110	80	18	1	11,5	136	3,75	KM22	ZM110
LOCKNUT-SOCKET-KM24	082782512-0000-10	155,8	170	62	110	80	18	1	11,5	146	3,57	KM24	ZM120

### 3.2 Hook wrenches LOCKNUT-HOOK

The hook wrenches LOCKNUT-HOOK in accordance with DIN 1810-A are suitable for the tightening and loosening of locknuts KM on shafts, adapter sleeves and withdrawal sleeves, if no tightening torque is specified.

The hook wrenches are suitable for locknuts KM0 to KM40. Special sizes are available by agreement.

Hook wrenches can be used to mount rolling bearings on tapered shaft seats, on adapter sleeves and on withdrawal sleeves. Withdrawal sleeves can also be dismounted using hook wrenches together with the extraction nuts.

Special sizes are available by agreement.

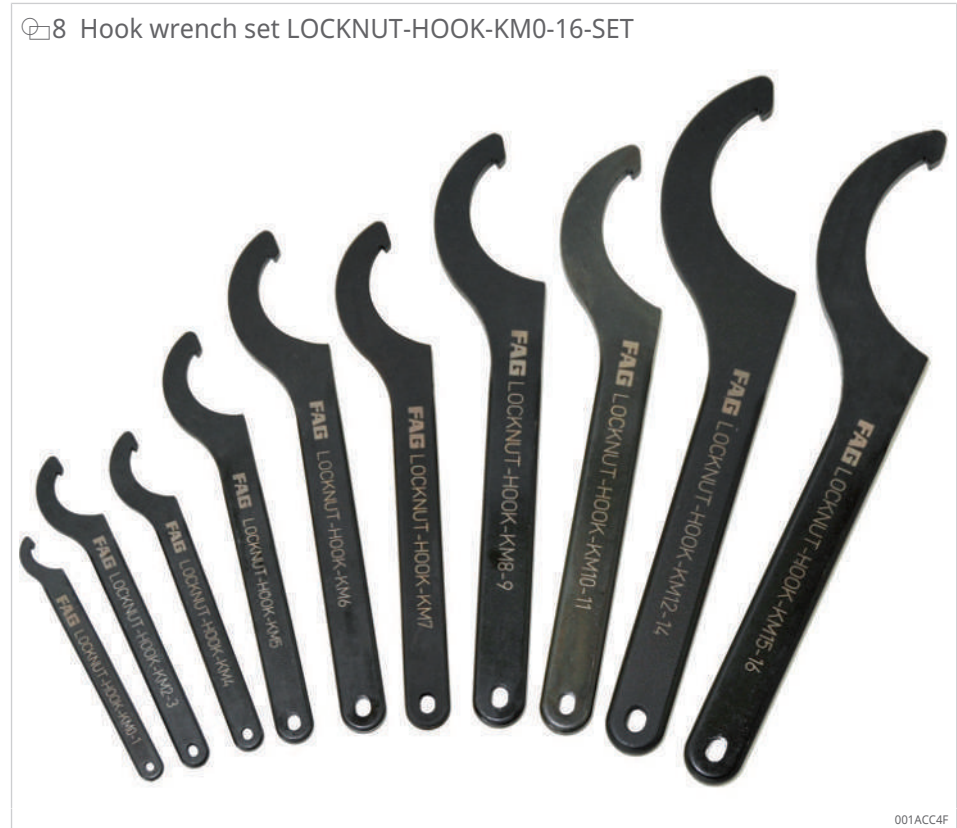

5 Hook wrench set LOCKNUT-HOOK-KM0-16-SET

Designation	Article number	Locknuts
LOCKNUT-HOOK-KM0-16-SET	076201767-0000-10	KM0...KM17

The set LOCKNUT-HOOK-KM0-16-SET contains hook wrenches for locknuts up to KM16. Hook wrenches can also be ordered as individual items.

9 LOCKNUT-HOOK dimensions

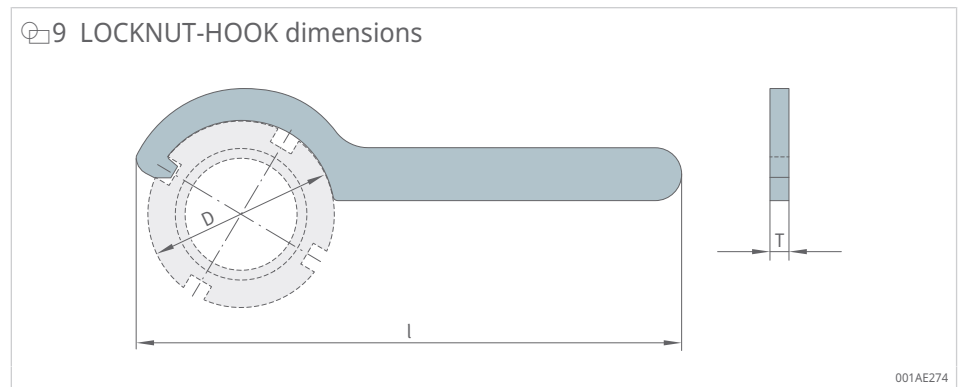

001AE274

3

6 LOCKNUT-HOOK designs

Designation	Article number	$D_{min}$	$D_{max}$	l	T	m	Locknuts
		mm	mm				
LOCKNUT-HOOK-KM0-1	039056660-0000-10	16	20	110	3	0,03	KM0, KM1
LOCKNUT-HOOK-KM2-3	039056678-0000-10	25	28	136	4	0,05	KM2, KM3
LOCKNUT-HOOK-KM4	039056686-0000-02	30	32	136	4	0,05	KM4
LOCKNUT-HOOK-KM5	039056694-0000-10	34	36	170	5	0,09	KM5
LOCKNUT-HOOK-KM6	039056708-0000-10	45	50	206	6	0,16	KM6
LOCKNUT-HOOK-KM7	039056716-0000-10	52	55	206	6	0,16	KM7
LOCKNUT-HOOK-KM8-9	039056724-0000-10	58	62	240	7	0,26	KM8, KM9
LOCKNUT-HOOK-KM10-11	039056732-0000-10	68	75	240	7	0,26	KM10, KM11
LOCKNUT-HOOK-KM12-14	039056740-0000-10	80	90	280	8	0,41	KM12, KM13, KM14
LOCKNUT-HOOK-KM15-16	039056759-0000-10	95	100	280	8	0,41	KM15, KM16
LOCKNUT-HOOK-KM17	039056767-0000-10	110	115	335	10	0,75	KM17
LOCKNUT-HOOK-KM18-20	039056775-0000-10	120	130	335	10	0,72	KM18, KM19, KM20
LOCKNUT-HOOK-KM21-23	039056791-0000-10	135	145	385	10	1	KM21, KM22, KM23
LOCKNUT-HOOK-KM24-27	039056805-0000-10	155	165	385	10	0,97	KM24, KM25, KM26, KM27
LOCKNUT-HOOK-KM28-30	039056813-0000-10	180	195	470	10	1,5	KM28, KM29, KM30
LOCKNUT-HOOK-KM31-34	039056821-0000-10	205	220	470	10	1,58	KM31, KM32, KM33, KM34
LOCKNUT-HOOK-KM36-40	039056848-0000-10	230	245	568	10	2,25	KM36, KM38, KM40

## 4 Tools for dismounting

### 4.1 Mechanical pullers

The mechanical puller MSP-2/3 facilitates the simple dismounting of complete rolling bearings of widely varying types and of tightly fitted inner rings. These pullers require good radial and axial accessibility of the bearing position, possibly with extraction slots.

The parts of the puller under mechanical load are made from high quality chromium-molybdenum steel.

10 Use of the mechanical puller MSP-2/3



001B009D

7 Overview of mechanical pullers

Feature		MSP-2/3
Grip width	mm	45...440
Extraction forc	kN	15...110
Self-centring		yes
Conversion between 2 and 3 arms possible		yes

### 4.1.1 Two-/three-arm pullers MSP-2/3

11 MSP-2/3



The mechanical pullers MSP-2/3 are available with extraction forces of 15 kN to 110 kN.

The puller is self-centring. The arms move inwards and outwards at the same time when the grip width is adjusted, which prevents the bearing from tilting during extraction and thus damage to the shaft and bearing.

If there is insufficient space for 3 arms, the puller can be simply converted to 2 arms.

#### Scope of delivery

12 Scope of delivery MSP-2/3



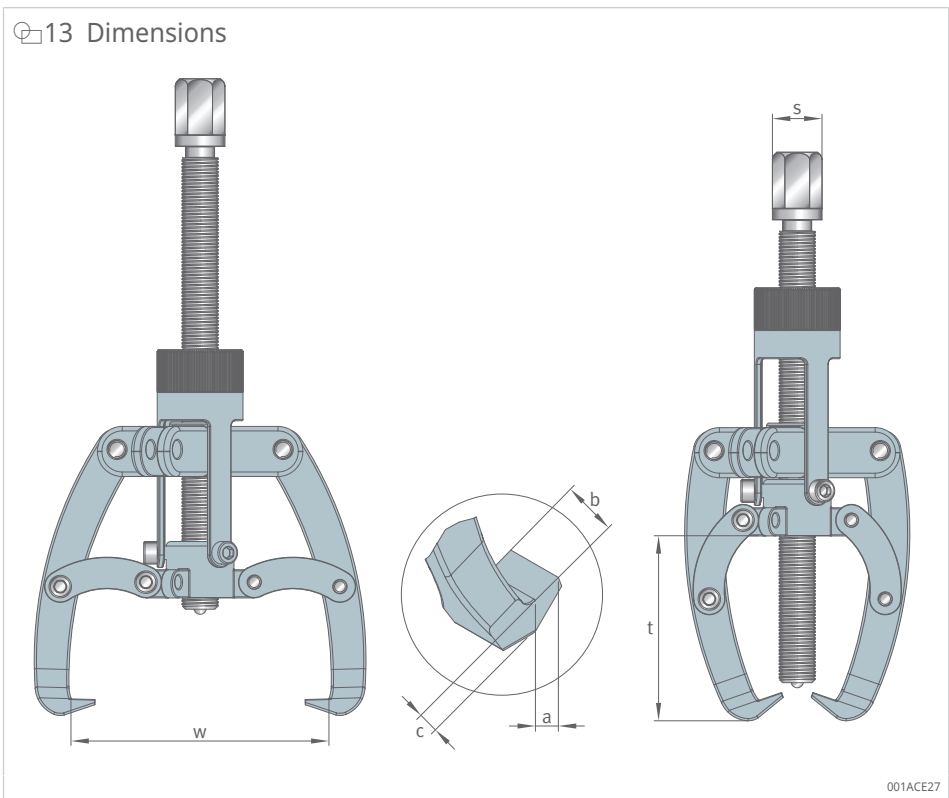

8 MSP-2/3 designs

Designation	Article number	$s$	$w_{min}$	$w_{max}$	$t_{max}$	$a$	$b$	$c$	$F_p$	$m$
		mm	mm	mm	mm	mm	mm	mm	kN	kg
MSP-2/3-120	300438923-0000-10	19	45	120	80	8	15	6	15	1,6
MSP-2/3-180	300438931-0000-10	19	95	180	120	6	15	7	25	2,3
MSP-2/3-270	300438940-0000-10	23	60	270	160	11	25	10	45	4,3
MSP-2/3-300	300438958-0000-10	23	55	300	210	13	27	14	75	6,1
MSP-2/3-380	300438966-0000-10	29	180	380	250	14	29	10	95	9,6
MSP-2/3-440	300438974-0000-10	29	180	440	250	14	29	10	110	11,2

$F_p$	kN	Extraction force
$m$	kg	Mass
$s$	mm	Spanner width
$t_{max}$	mm	max. grip depth
$w_{min}$	mm	min. grip width
$w_{max}$	mm	max. grip width



## 4.2 Hydraulic pullers

The hydraulic pullers HP and HSP have an integrated pump and cylinder. A safety valve prevents overloading and ensures that the maximum force is not exceeded. The pullers HXP require a separate hydraulic hand pump.

The parts of the puller under mechanical load are made from high quality chromium-molybdenum steel.

4

14 Use of the hydraulic puller HSP



001B00CD

9 Overview of hydraulic pullers

Feature		HP	HSP	HXP	TRI-SECTION-SET
Grip width	mm	~...550	83...620	95...860	30...340
Extraction force	kN	35...290	35...290	75...490	35...110
Self-centring		no	yes	yes	no
Integrated pump and cylinder		yes	yes	no	yes

## 4.2.1 Two-/three-arm pullers HP



The hydraulic pullers HP are available with extraction forces of 35 kN to 290 kN. If there is insufficient space for 3 arms, the puller can be simply converted to 2 arms.

The grip depth can be adjusted by means of the adapter included in the scope of delivery. The number of adapters varies according to the design of the puller.

The lightweight telescopic handle can be rotated 360°, the operator can always adopt the optimum working position as the puller can be used in any position.

## Scope of delivery

 16 Scope of delivery HP

0018095A

1	HP	2	Centring piece with spring-loaded centring tip
3	Adapter	4	Safety mesh or safety sleeve, depending on the size of the puller
5	Case		

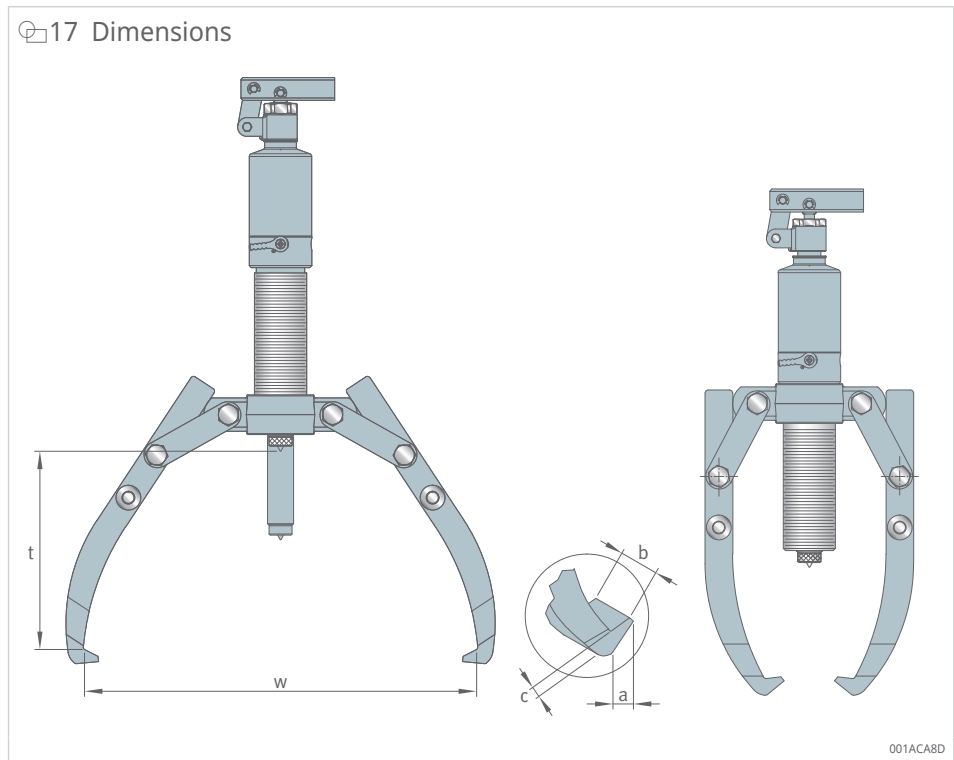

10 HP designs

Designation	Article number	$w_{min}$	$w_{max}$	$t_{max}$	a	b	c	Stroke	$F_p$	m
		mm	mm	mm	mm	mm	mm		mm	kN
HP-43	300504489-0000-10	-	255	185	11	22	6	60	35	4,5
HP-63	300504497-0000-10	-	330	220	13	22	10	70	55	6,3
HP-83	300504519-0000-10	-	350	230	11	25	10	85	75	6,5
HP-123	300504683-0000-10	-	375	270	14	29	10	85	110	8
HP-203	300504926-0000-10	-	520	360	20	33	27	111	190	22
HP-303	300504934-0000-10	-	550	360	20	38	27	111	290	32

$F_p$  kN Extraction force  
 m kg Mass  
 $t_{max}$  mm max. grip depth  
 $w_{min}$  mm min. grip width  
 $w_{max}$  mm max. grip width

## 4.2.2 Two-/three-arm pullers HSP



The hydraulic pullers HSP are available with extraction forces of 35 kN to 290 kN.

The puller is self-centring. The arms move inwards and outwards at the same time when the grip width is adjusted, which prevents the bearing from tilting during extraction and thus damage to the shaft and bearing.

If there is insufficient space for 3 arms, the puller can be simply converted to 2 arms.

The grip depth can be adjusted by means of the adapter included in the scope of delivery. The number of adapters varies according to the design of the puller.

The lightweight telescopic handle can be rotated 360°, the operator can always adopt the optimum working position as the puller can be used in any position.

Scope of delivery

📦 19 Scope of delivery HSP



001AE284

1	HSP	2	Centring piece with spring-loaded centring tip
3	2× Adapter, depending on the size of the puller	4	Safety mesh or safety sleeve, depending on the size of the puller
5	Case		

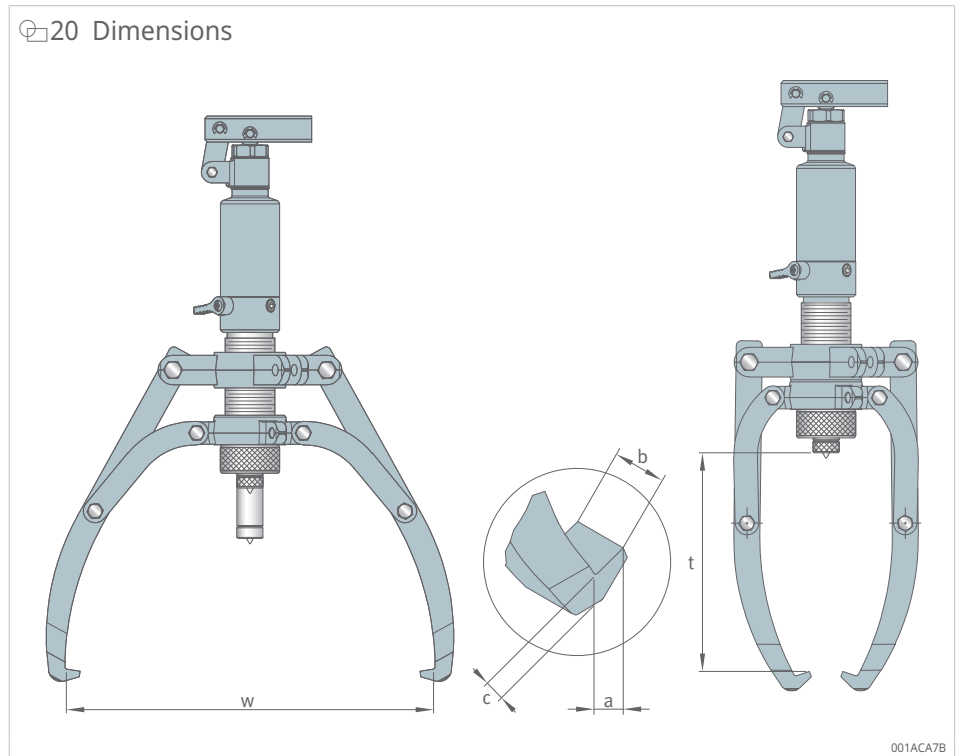

### 11 HSP designs

Designation	Article number	$w_{min}$	$w_{max}$	$t_{max}$	$a$	$b$	$c$	Stroke	$F_p$	$m$
		mm	mm	mm	mm	mm	mm			
HSP-43	300511388-0000-10	83	315	190	13	22	10	60	35	8
HSP-63	300511396-0000-10	90	390	230	13	22	10	70	55	10
HSP-83	300511400-0000-10	110	460	280	13	27	13	85	75	12
HSP-123	300511418-0000-10	120	515	300	15	29	16,5	85	110	15
HSP-203	300511620-0000-10	160	520	325	18	33	20	111	190	26
HSP-303	300511639-0000-10	190	620	415	18	38	20	111	290	36

$F_p$	kN	Extraction force
$m$	kg	Mass
$t_{max}$	mm	max. grip depth
$w_{min}$	mm	min. grip width
$w_{max}$	mm	max. grip width

## 4.2.3 Two-/three-arm pullers HXP



The hydraulic pullers HXP are available with extraction forces of 75 kN to 490 kN.

The puller is self-centring. The arms move inwards and outwards at the same time when the grip width is adjusted, which prevents the bearing from tilting during extraction and thus damage to the shaft and bearing.

If there is insufficient space for 3 arms, the puller can be simply converted to 2 arms.

The grip depth can be adjusted by means of the adapter included in the scope of delivery. The number of adapters varies according to the design of the puller.



A separate hydraulic pump AHP is required for operation ▶30|4.3.1.



## Scope of delivery

 22 Scope of delivery HXP

001B0BB1

1	HXP	2	Centring piece with spring-loaded centring tip
3	Adapter, depending on the size of the puller	4	Safety mesh or safety sleeve, depending on the size of the puller
5	Case		

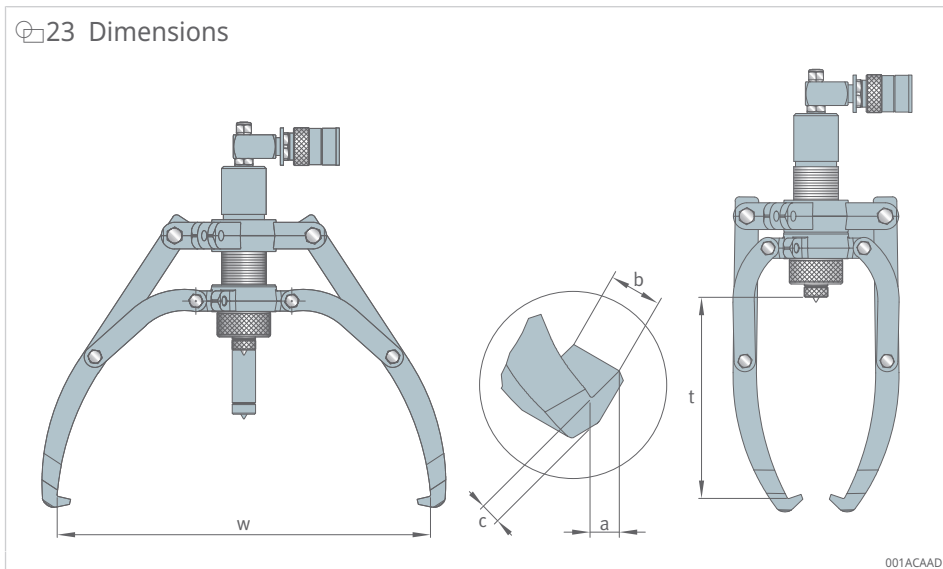

12 HXP designs

Designation	Article number	$w_{min}$	$w_{max}$	$t_{max}$	$a$	$b$	$c$	Stroke	$F_p$	$m$	Suitable hydraulic pump
		mm	mm	mm	mm	mm	mm		mm	kN	
HXP-83	300513437-0000-10	95	460	280	13	22	10	85	75	9	AHP-701-SET
HXP-123	300513445-0000-10	100	515	300	13	27,5	13	85	110	11,7	AHP-701-SET
HXP-203	300513453-0000-10	110	520	325	15	29	16,5	111	190	24	AHP-702-SET
HXP-303	300513461-0000-10	120	620	415	20	33	27	111	290	34	AHP-702-SET
HXP-503	300513470-0000-10	160	860	455	23	60	35	159	490	140	AHP-703-SET

$F_p$  kN Extraction force  
 $m$  kg Mass  
 $t_{max}$  mm max. grip depth  
 $w_{min}$  mm min. grip width  
 $w_{max}$  mm max. grip width

#### 4.2.4 Three-arm pullers TRI-SECTION-SET



The hydraulic pullers TRI-SECTION-SET are available with extraction forces of 35 kN to 110 kN.

The hydraulic cylinder is positioned in the puller block and connected to the TRI-SECTION-PLATE with 3 connection rods.

The extraction plates are suitable for mounting situations where a three-arm puller on its own cannot be used to achieve gentle extraction by means of the inner ring.

Alternatively, the hydraulic pullers HP, HSP and HXP can also be used with a separately available extraction plate ▶32 | 4.3.2.

The grip depth can be adjusted by means of the adapter included in the scope of delivery. The number of adapters varies according to the design of the puller.

The lightweight telescopic handle can be rotated 360°, the operator can always adopt the optimum working position as the puller can be used in any position.

## Scope of delivery

25 Scope of delivery TRI-SECTION-SET



001B0C0C

1	Hydraulic unit	2	TRI-SECTION-PLATE
3	Adapter	4	Connection rods
5	Crossbar	6	Centring piece with spring-loaded centring tip
7	Case		

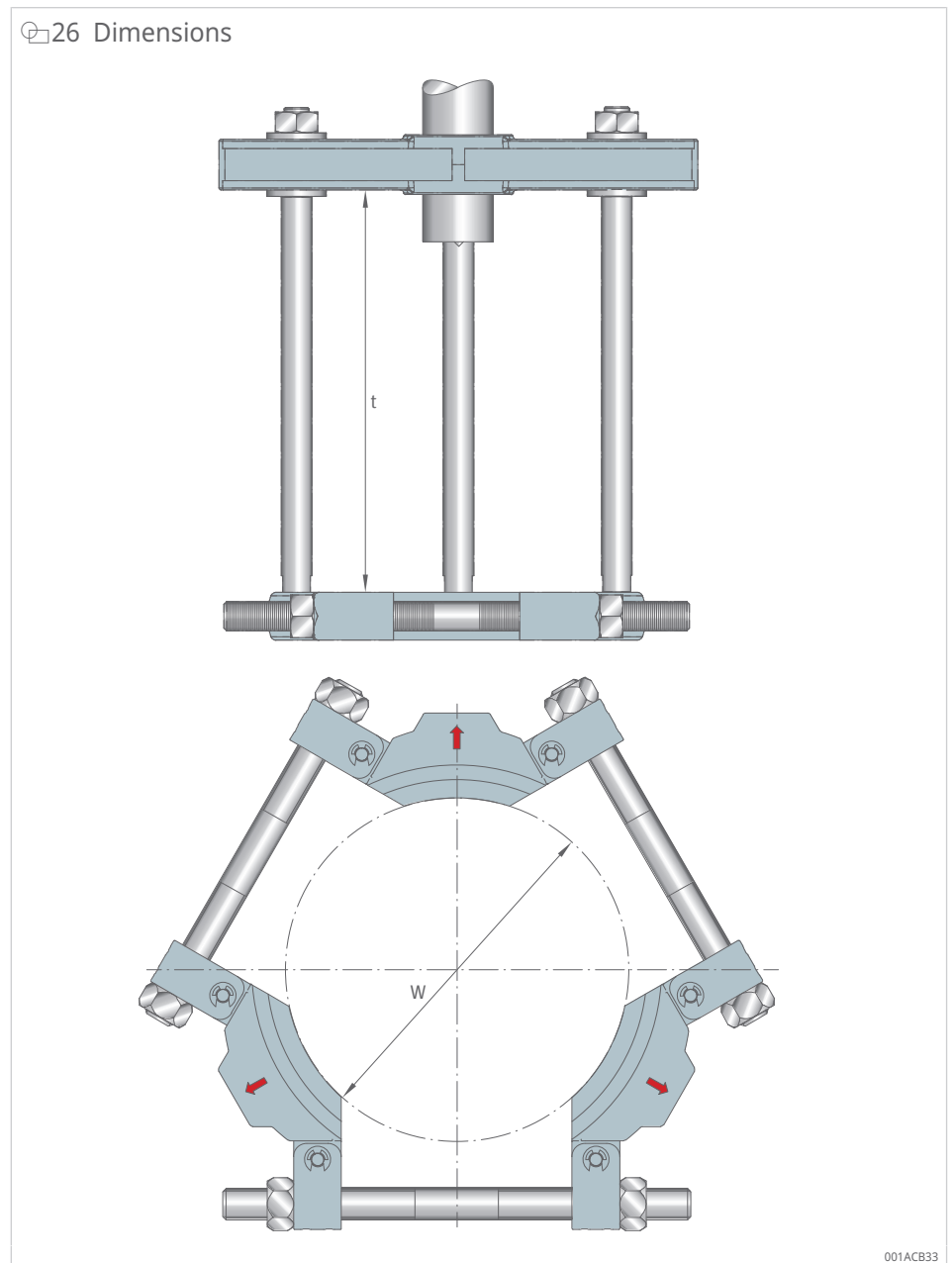
 26 Dimensions

 13 TRI-SECTION-SET designs

Designation	Article number	$w_{\min}$	$w_{\max}$	$t_{\max}$	Stroke	$F_p$	m
		mm	mm	mm			
TRI-SECTION-SET-4T	300690371-0000-10	30	160	211	-	35	20
TRI-SECTION-SET-6T	300690380-0000-10	50	210	243	-	55	30
TRI-SECTION-SET-8T	300690398-0000-10	50	270	243	-	75	34
TRI-SECTION-SET-12T	300690401-0000-10	90	340	284	-	110	68

 $F_p$ 

kN

Extraction force

m

kg

Mass

 $t_{\max}$ 

mm

max. grip depth

 $w_{\min}$ 

mm

min. grip width

 $w_{\max}$ 

mm

max. grip width

## 4.3 Accessories

### 4.3.1 Hydraulic pump AHP

The hand pump AHP is needed in order to operate puller HXP.

The hand pump has 2 stages to ensure a rapid build-up of pressure.

The aluminium alloy construction and practical pressure release button with locking mechanism render these pumps particularly suitable for industrial applications and day-to-day operations.

The hand pump is fitted with an overload valve (700 bar) to protect the hydraulic components.

#### Scope of delivery

☞ 27 Scope of delivery of hydraulic pump AHP



1	AHP	2	Hose
3	Tee fitting	4	Manometer
5	Case	6	Coupling nipples and coupling sleeves

#### 14 AHP designs

Designation	Article number	$p_1$	$p_{max}$	$\dot{V}_{H1}$	$\dot{V}_H$	$\dot{V}_{max}$	$V_{eff}$	L	B	H	m	Hose connector
		bar	bar	cm <sup>3</sup>	cm <sup>3</sup>	cm <sup>3</sup>	l	mm	mm	mm	kg	
AHP-701-SET	300824173-0000-10	20	700	12,9	1,65	0,5	0,35	391	110	140	10,4	3/8" NPT
AHP-702-SET	300824181-0000-10	20	700	12,9	1,65	1	0,75	542	110	130	11,1	3/8" NPT
AHP-703-SET	300824190-0000-10	20	700	12,9	2,3	2	1,62	623	150	135	18,1	3/8" NPT

4

$p_1$	bar	Operating pressure, 1st stage
$p_{max}$	bar	max. operating pressure
$\dot{V}_{H1}$	cm <sup>3</sup>	Oil flow per stroke, 1st stage
$\dot{V}_H$	cm <sup>3</sup>	Oil flow rate per stroke
$V_{max}$	l	max. volume of the oil container
$V_{eff}$	l	Usable oil quantity
L	mm	Length
B	mm	Width
H	mm	Height
m	kg	Mass

### 4.3.2 Three-section extraction plates TRI-SECTION-PLATE

The three-section extraction plates TRI-SECTION-PLATE are used for the extraction of complete bearings or tightly fitted inner rings.

28 Dismounting with the TRI-SECTION-PLATE

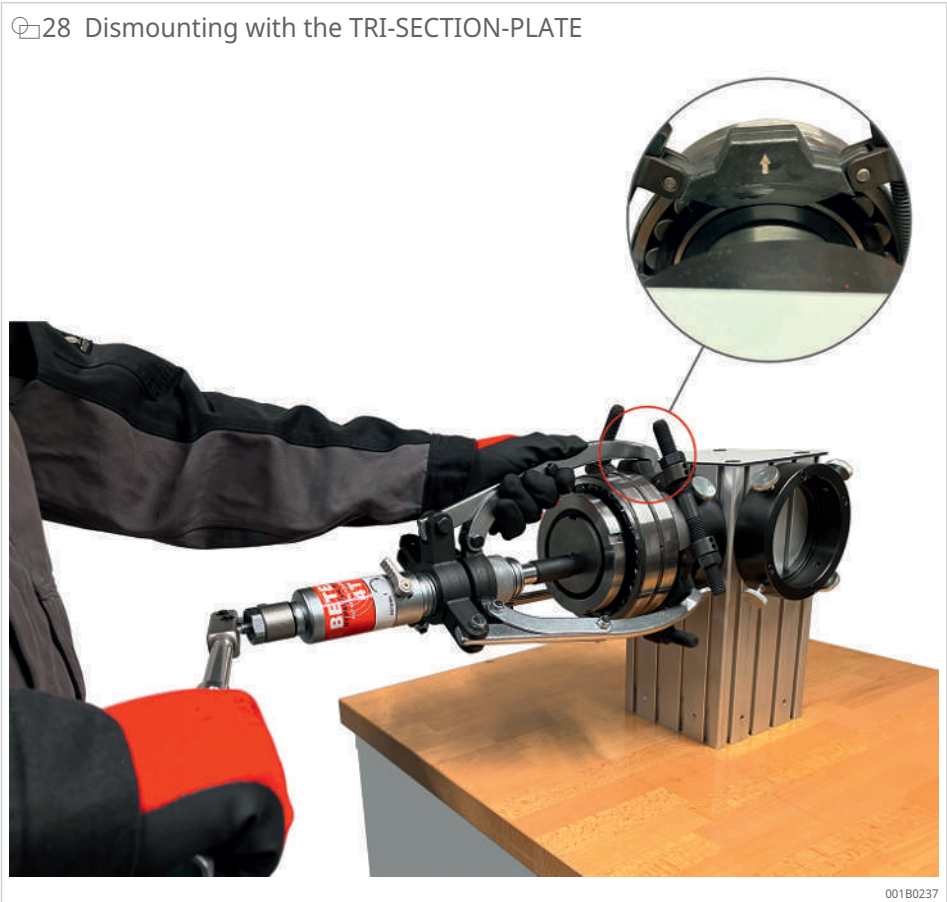

001B0237

The three-section extraction plates TRI-SECTION-PLATE are suitable for shaft diameters from 26 mm to 495 mm, depending on the design, and are used in conjunction with three-arm pullers.

If the puller does not engage with the bearing inner ring with good radial access to the bearing position, inner rings or complete rolling bearings can be extracted without damage using the extraction plates.

The 3 extraction plates are pushed, by means of alternately screwing in the nuts, between the shaft shoulder and inner ring. This is supported by the special geometry of the extraction plates.

The bearing is extracted by means of a puller that is inserted into the plates.

The extraction tool should be placed on the bearing inner ring to prevent the rolling elements from pressing into the bearing raceways.

The side marked with an arrow must be facing away from the bearing if gentle extraction is to be achieved by means of the inner ring.



29 Three-section extraction plate TRI-SECTION-PLATE



001ACCOF

15 Possible combinations TRI-SECTION-PLATE

Designation	Can be combined with			
	MSP-2/3	HP	HSP	HXP
TRI-SECTION-PLATE-160	180, 270	43, 63	43, 63	43, 63
TRI-SECTION-PLATE-210	270, 300	63, 83	63, 83	63, 83
TRI-SECTION-PLATE-340	300, 380, 440	83, 203, 303	83, 203, 303	83, 203, 303
TRI-SECTION-PLATE-495	-	203, 303	203, 303	203, 303

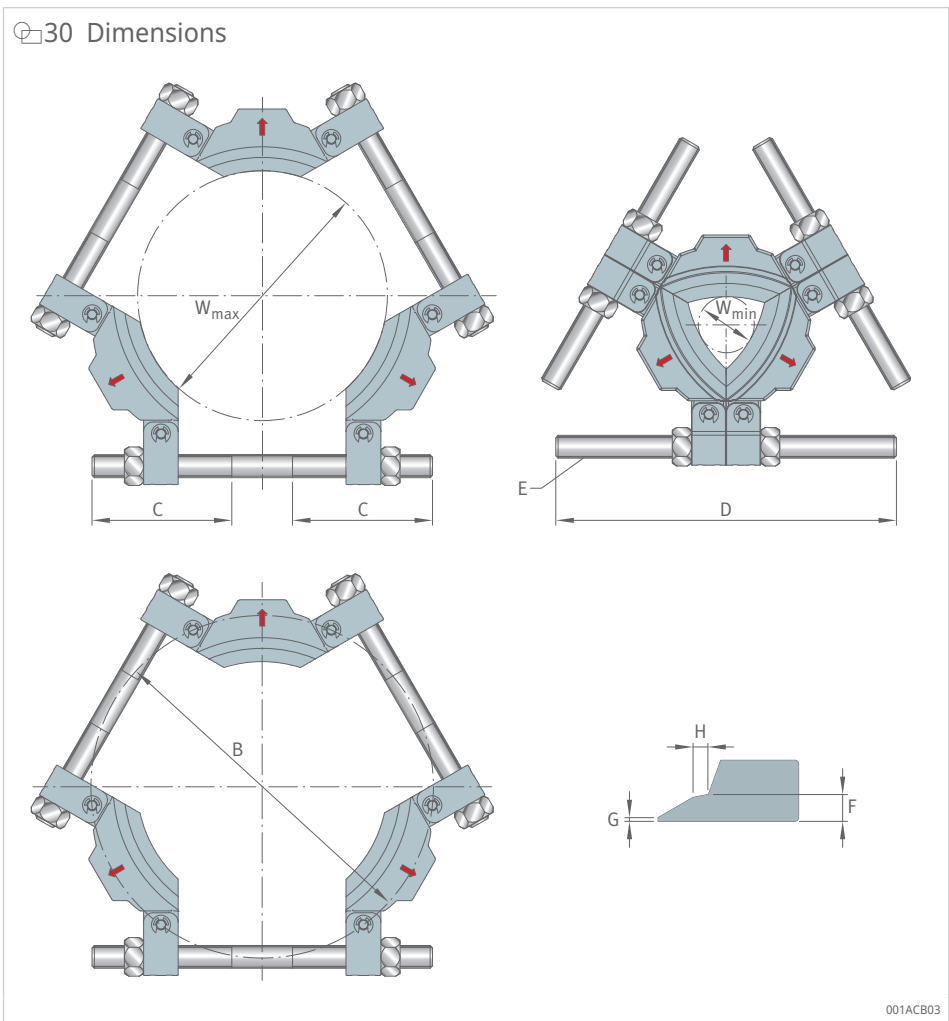

16 TRI-SECTION-PLATE designs

Designation	Article number	$w_{min.}$ mm	$w_{max.}$ mm	$B_{max}$ mm	C mm	D mm	E -	F mm	G mm	H mm	$F_{z max.}$ kN	m kg
TRI-SECTION-PLATE-160	300687710-0000-10	26	160	216	105	240	5/8"-11 UNC	8	2	6,5	55	3,5
TRI-SECTION-PLATE-210	300688628-0000-10	50	210	280	117	285	7/8"-14 UNF	10	2	9	75	5,5
TRI-SECTION-PLATE-340	300688636-0000-10	90	340	460	175	430	1 1/4"-12 UNF	14	2	8	190	18
TRI-SECTION-PLATE-495	300688644-0000-10	140	495	660	235	610	1 3/4"-12 UNF	20	2	12	290	45

$F_{z max}$	N	max. permissible extraction force
m	kg	Mass
$t_{max}$	mm	max. grip depth
$w_{max}$	mm	max. grip width
$w_{min}$	mm	min. grip width

### 4.3.3 Extraction plate set ACC-SET

31 Application example ACC-SET



001802A7

The extraction plate set ACC-SET is suitable for shaft diameters from 12 mm to 225 mm, depending on the design, and is used with the hydraulic unit of hydraulic pullers HP, HSP and HXP.

The two-section extraction plates are suitable for the gentle dismounting of complete bearings, bearing inner rings and other components, whereby the extraction force is not transmitted via moving parts.

Good radial access to the part to be dismounted is required.

The 2 extraction plates are pushed, by means of alternately screwing in the nuts, between the shaft shoulder and inner ring. This is supported by the special geometry of the extraction plates.

The flat side of the extraction plate must be facing the bearing if gentle extraction is to be achieved by means of the inner ring.

## Scope of delivery

32 Scope of delivery ACC-SET-HP43-HSP43



001B0A8F

1	Crossbar	2	Extraction rods
3	Extraction plate set	4	Case

**!** The hydraulic unit is not included in the scope of delivery.

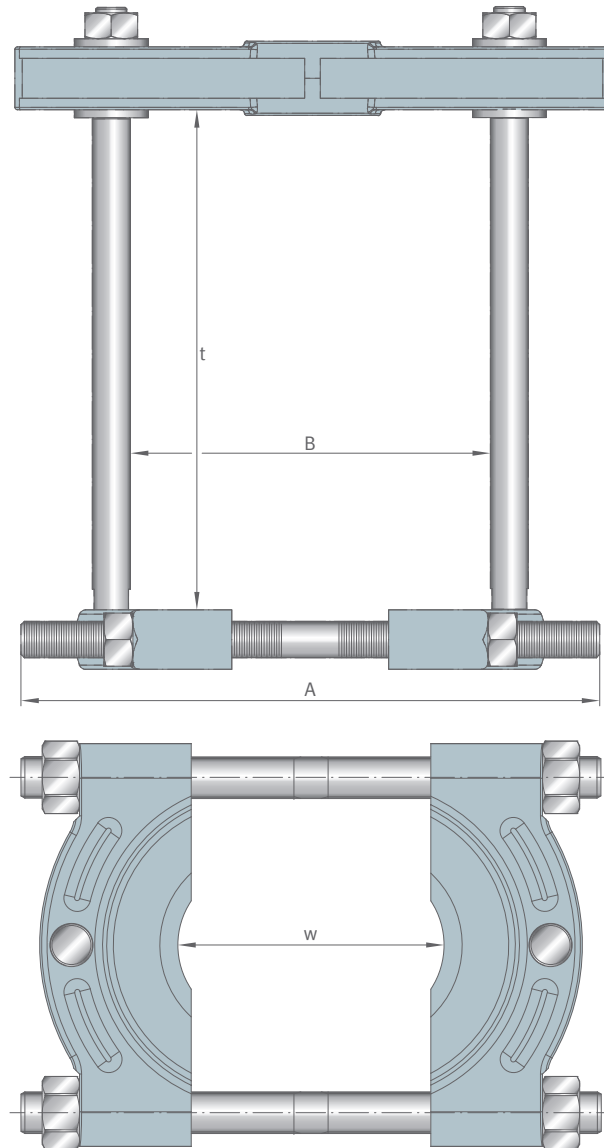
 33 Dimensions

001ACB13

 17 ACC-SET designs

Designation	Article number	$w_{\min}$	$w_{\max}$	$t_{\max}$	A	$B_{\min}$	$B_{\max}$	$F_{z \max}$	m
		mm	mm	mm					
ACC-SET-HP43-HSP43	300690118-0000-10	12	70	224	163	100	145	35	7,5
ACC-SET-HP63-HSP63	300690100-0000-10	28	150	255	260	110	220	55	11,5
ACC-SET-HP83-HSP83-HXP83	300691025-0000-10	28	150	255	260	115	230	75	12
ACC-SET-HP123-HSP123-HXP123	300691033-0000-10	40	225	298	360	140	310	110	21

 $F_{z \max}$ 

N

max. permissible extraction force

m

kg

Mass

 $t_{\max}$ 

mm

max. grip depth

 $w_{\max}$ 

mm

max. grip width

 $w_{\min}$ 

mm

min. grip width

## 5 Accessories

### 5.1 Transport and mounting tool BEARING-MATE

The transport and mounting tool BEARING-MATE is an accessory for the secure, rapid and easy handling of medium-sized and large rolling bearings. It can also be used where bearings are heated prior to mounting.

The tool comprises two handles and two steel strips. Turning the handles clamps the steel strips firmly on the outer ring of the rolling bearing. The compact packaging also includes two brackets. These are used on self-aligning ball bearings and spherical roller bearings in order to prevent tilting of the inner rings.

34 Use of BEARING-MATE



00180673

The tool and bearing are carried either by 2 people or a crane. If 2 carrying slings are used, the rolling bearing can be rotated to any position when transported by crane. During heating on an induction heating device, the tool remains mounted on the bearing. The steel strips expand uniformly with the bearing. Optimum tension is thus maintained.

## Scope of delivery

35 Scope of delivery BEARING-MATE



001ACC9F

1	BEARING-MATE	2	Short bracket (2×)
3	Multi-purpose grease Arcanol Multi2 in a 20g tube		

### 18 Accessories

Description	Ordering designation
2 long brackets to prevent tilting of the inner rings of self-aligning bearings	BEARING-MATE.LOCKBAR270

### 19 Replacement parts

Description	Ordering designation
2 short brackets to prevent tilting of the inner rings of self-aligning bearings	BEARING-MATE.LOCKBAR170
Pack of small parts <ul style="list-style-type: none"> <li>• Replacement labels for BEARING-MATE</li> <li>• 20 g tube of Arcanol MULTI2</li> </ul>	BEARING-MATE.SERVICE-KIT

The transport and mounting tool is available in 4 designs with steel strips of differing lengths. This can be used to transport bearings with outside diameters from 250 mm to 1050 mm.

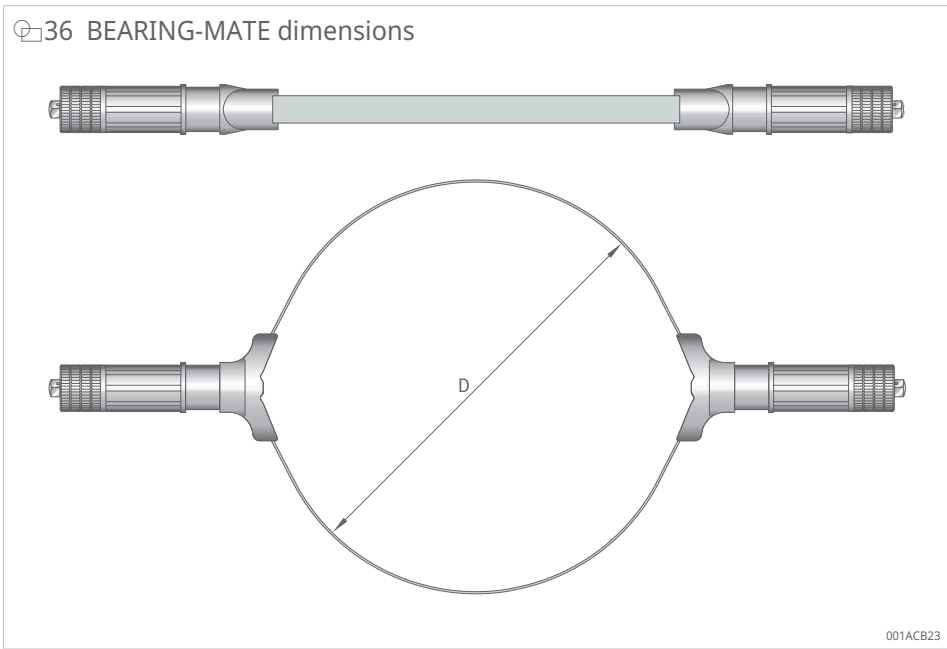

20 BEARING-MATE designs

Designation	Article number	Bearing parameters			T <sub>max</sub>	m
		D <sub>min</sub> mm	D <sub>max</sub> mm	m kg		
BEARING-MATE250-450	038888386-0000-10	250	450	500	160	6,3
BEARING-MATE450-650	039620468-0000-10	450	650	500	160	6,4
BEARING-MATE650-850	039620476-0000-10	650	850	500	160	6,5
BEARING-MATE850-1050	093165803-0000-10	850	1050	500	160	6,85

D <sub>min</sub>	mm	min. outside diameter
D <sub>max</sub>	mm	max. outside diameter
m	kg	Mass
T <sub>max</sub>	°C	max. temperature



## 6 Service and replacement parts

### 6.1 Service

Schaeffler service portal:  
<https://schaeffler-sms.schaeffler.com>

Service Smart Maintenance Tools:  
[or-hzr-tool-repair@schaeffler.com](mailto:or-hzr-tool-repair@schaeffler.com)

### 6.2 Replacement parts

Information about replacement parts:  
[or-hzr-tool-repair@schaeffler.com](mailto:or-hzr-tool-repair@schaeffler.com)

**Schaeffler Technologies AG & Co. KG**

Georg-Schäfer-Straße 30

97421 Schweinfurt

Germany

[www.schaeffler.de/en/services](http://www.schaeffler.de/en/services)

Technical support:

[www.schaeffler.de/en/technical-support](http://www.schaeffler.de/en/technical-support)

All information has been carefully compiled and checked by us, but we cannot guarantee complete accuracy. We reserve the right to make corrections. Therefore, please always check whether more up-to-date or amended information is available. This publication supersedes all deviating information from older publications. Printing, including excerpts, is only permitted with our approval.  
© Schaeffler Technologies AG & Co. KG  
TPI 216 / 05 / en-GB / DE / 2024-05