



COMPANY WITH
QUALITY SYSTEM
CERTIFIED BY DNV GL
= ISO 9001 =

INDUSTRIES
SUPPORTI AUTOALLINEANTI
SELF-ALIGNING BEARING UNITS



CATALOGO TECNICO GENERALE
GENERAL TECHNICAL CATALOGUE



01.09.19

www.isb-industries.com

Supporti autoallineanti

Self-aligning bearing units



**DISPONIBILI SUPPORTI PER ALTE TEMPERATURE
HIGH TEMPERATURES BEARING UNITS AVAILABLE**

Supporti INOX

Stainless steel bearing units



Supporti in plastica

Plastic bearing units



GENERAL SALES PROGRAM

PROGRAMMA GENERALE DI VENDITA



Components for linear motion *
*Componenti per la
movimentazione lineare **



Bearings and components *
*Cuscinetti e componenti **

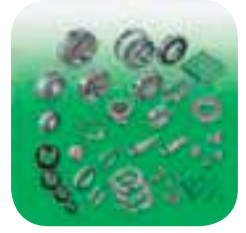

Super precision bearings *
*Cuscinetti di super precisione **



ELECTRICAL MOTORS STANDARD

Bearings for "low noise" applications *
*Cuscinetti per applicazioni
"bassa rumorosità" **

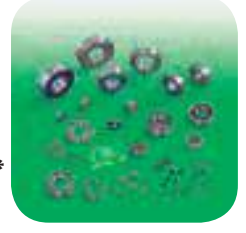

Slewing bearings *
*Cuscinetti di base **



Needle bearings *
*Cuscinetti a rullini **



**Spherical plain bearings
rod ends - clevises ***
*Snodi sferici
teste a snodo - forcelle **



Self-aligning bearing units *
*Supporti autoallineanti **



Free wheels *
*Ruote libere **



Bushes *
*Boccole **



**Bearings and Self-aligning
bearing units ***
*Cuscinetti e supporti
autoallineanti **



Products in stainless steel
Prodotti in acciaio inox



* For further information, please ask for technical catalogue, also available on line: www.isb-industries.com

* Per ulteriori informazioni, potete richiedere il catalogo tecnico, disponibile anche on line: www.isb-industries.com



CATALOGO TECNICO GENERALE
GENERAL TECHNICAL CATALOGUE

Distributore / Distributor



ISB LINEAR SYSTEMS CENTER

ISB CENTRO AMERICA

ISB BRASIL

■ PLANTS
■ BRANCHES

- | | | | |
|----------------|----------------|-------------------------|---------------|
| 1 ALGERIA | 12 BULGARIA | 23 DENMARK | 34 JAPAN |
| 2 ANGOLA | 13 CANADA | 24 ECUADOR | 35 JORDAN |
| 3 SAUDI ARABIA | 14 CHILE | 25 EGYPT | 36 INDIA |
| 4 ARGENTINA | 15 CHINA | 26 EL SALVADOR | 37 IRELAND |
| 5 ARMENIA | 16 CYPRUS | 27 UNITED ARAB EMIRATES | 38 ICELAND |
| 6 AUSTRALIA | 17 COLOMBIA | 28 ESTONIA | 39 ISRAEL |
| 7 AUSTRIA | 18 SOUTH KOREA | 29 FINLAND | 40 ITALY |
| 8 AZERBAIJAN | 19 IVORY COAST | 30 FRANCE | 41 KAZAKHSTAN |
| 9 BELARUS | 20 COSTA RICA | 31 GERMANY | 42 KENYA |
| 10 BELGIUM | 21 CROATIA | 32 GREECE | 43 LATVIA |
| 11 BRAZIL | 22 CUBA | 33 GUATEMALA | 44 LEBANON |

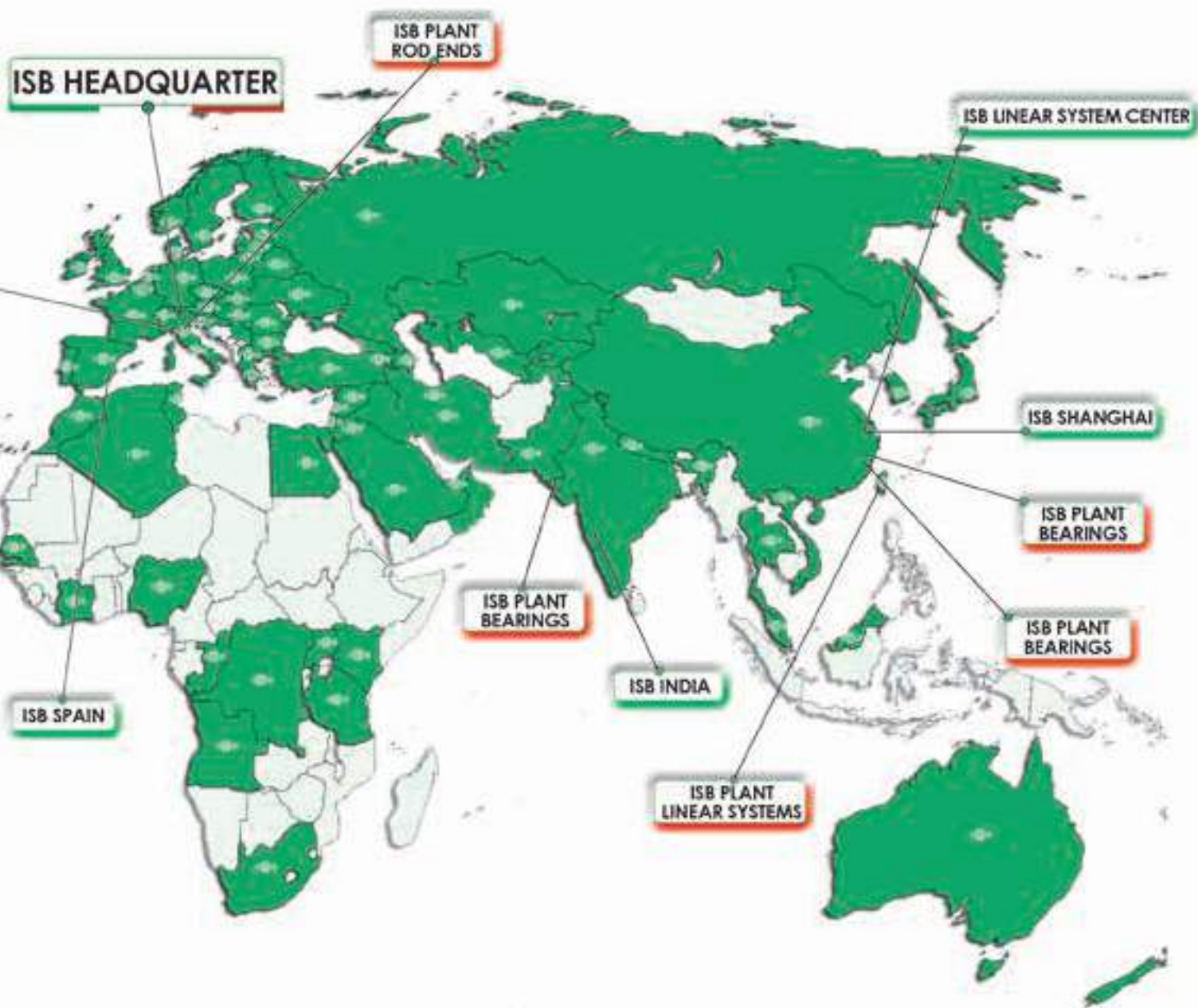

OUR DISTRIBUTORS IN THE WORLD

45 LITHUANIA	56 PANAMA	67 RUMANIA	78 SWITZERLAND
46 MACEDONIA	57 PAKISTAN	68 RUSSIA	79 TAIWAN
47 MALAYSIA	58 PERU	69 SAN MARINO	80 TANZANIA
48 MALTA	59 POLAND	70 SÉNÉGAL	81 THAILANDIA
49 MOROCCO	60 PORTUGAL	71 SERBIA	82 TUNISIA
50 MEXICO	61 UNITED KINGDOM	72 SYRIA	83 TURKEY
51 NICARAGUA	62 REPUBLIQUE of the CONGO	73 SLOVENIA	84 UKRAINE
52 NIGERIA	63 DEM. REP. of the CONGO	74 SPAIN	85 REPUBLIC OF UGANDA
53 NORWAY	64 CZECH REPUBLIC	75 UNITED STATES of AMERICA	86 HUNGARY
54 NEW ZEALAND	65 DOMINICAN REPUBLIC	76 SOUTH AFRICA	87 UZBEKISTAN
55 NETHERLANDS	66 SLOVAKIAN REPUBLIC	77 SWEDEN	88 VIETNAM
			89 VENEZUELA

Tutti i prodotti **ISB®** sono costruiti esclusivamente da aziende con Sistema Qualità certificato secondo le norme UNI EN ISO 9001

*All products **ISB®** are manufactured exclusively by companies with UNI EN ISO 9001 certified Quality System.*



**... un'ulteriore serie di controlli vengono eseguiti da Laboratori esterni specializzati, attrezzati con moderni strumenti.
Laboratorio Controllo Qualità.**

**... an additional series of tests are conducted by specialised third party Laboratories using the latest instruments.
Quality Control Laboratory.**



... centro di controllo per la qualità nella nostra sede in ITALIA.

... uno staff di Ingegneri tecnici della Qualità, al vostro servizio.



... a quality control centre is located in our ITALY headquarters.

... our staff of technical engineers at yr service, for Quality.



ISIR N° 0015
Rapporto di controllo di prima campionatura
Initial Sample Inspection Report

DENOMINAZIONE Part name: **Supporto UFL 005**
Fornitore Supplier name: **CF 595**

CODICE ARTICOLO Part number: **31095120**
CODICE FORNITORE Supplier code: **WJBXXITA04-S**

QTA CONSEGNERATA Delivered quantity: **10**
QTA CONTROLLATA Inspected quantity: **10**

ISPEZIONATO DA Inspected by: **Quality Control**
DATA Date: **13/09/2010**

DATA Date: **09/09/2010**

Caratteristiche controllate / Inspected characteristics

Posizione Key	Dimensione nominale Specifiche materiali Nominal dimension Material specification	Unità di misura Unit of measure	Tolleranze Tolerances	Risultati della misurazione Measurement results				
				Articolo 1 Piece	Articolo 2 Piece	Articolo 3 Piece	Articolo 4 Piece	Articolo 5 Piece
1	Bore Ø 25 (d)	mm	0 / +0,021	25,010	25,009	25,012	25,008	25,009
2	Quote 22,5 (a)	mm	0 / -0,120	22,410	22,420	22,415	22,430	22,410
3	Quote 95 (a)	mm	-	94,85	94,95	94,89	94,88	94,85
4	Quote 75 (e)	mm	-	10,10	10,12	10,09	10,12	10,10
5	Holes Ø 10	mm	-	15,95	15,98	15,96	16,02	16,02
6	Quote 16 (l)	mm	-	24,45	24,40	24,50	24,4	24,4
7	Quote 24,5 (z)	mm	-	59,48	59,52	59,60	59,45	59,45
8	Quote 60 (b)	mm	61 ± 2	60,8	60,9	61,5	61,1	61,1
9	Hardness (HRC)	HRC	53 ± 2	53,5	53,8	54,1	53,5	53,5
10	Hardness (HRC)	HRC	53 ± 2	53,5	53,8	54,1	53,5	53,5
11								
12								
13								
14								
15								
16								
Peso del campione Sample weight:			kg.	0,218				

Relazioni di prova, documenti allegati / Test report documents attached

1. Deviazione Deviation n.:	Decisioni Decisions	Approvato Approve					Respiro Fail					Deroga Deviate
		Articolo 1 Piece	Articolo 2 Piece	Articolo 3 Piece	Articolo 4 Piece	Articolo 5 Piece	Articolo 1 Piece	Articolo 2 Piece	Articolo 3 Piece	Articolo 4 Piece	Articolo 5 Piece	
1.	Dimensioni Dimensions	X	X	X	X	X						
2.	Laboratorio Laboratory											
3.	Funzionalità Functionality											
4.	Aspetto Appearance	X	X	X	X	X						

ISIR N° 0015
Rapporto di controllo di prima campionatura
Initial Sample Inspection Report

DENOMINAZIONE Part name: **Supporto UFL 005**
Fornitore Supplier name: **CF 595**

CODICE ARTICOLO Part number: **31095120**
CODICE FORNITORE Supplier code: **WJBXXITA04-S**

QTA CONSEGNERATA Delivered quantity: **10**
QTA CONTROLLATA Inspected quantity: **10**

ISPEZIONATO DA Inspected by: **Quality Control**
DATA Date: **13/09/2010**

DATA Date: **09/09/2010**

Caratteristiche controllate / Inspected characteristics

Posizione Key	Dimensione nominale Specifiche materiali Nominal dimension Material specification	Unità di misura Unit of measure	Tolleranze Tolerances	Risultati della misurazione Measurement results					Esito Result	Verifica Control
				Articolo 6 Piece	Articolo 7 Piece	Articolo 8 Piece	Articolo 9 Piece	Articolo 10 Piece		
1	Bore Ø 25 (d)	mm	0 / +0,021	25,005	25,005	25,005	25,007	25,007	X	OK
2	Quote 22,5 (B)	mm	0 / -0,120	22,405	22,410	22,410	22,400	22,420	X	OK
3	Quote 95 (a)	mm	-	94,99	94,97	94,92	94,94	94,99	X	OK
4	Quote 75 (e)	mm	-	10,13	10,05	10,05	10,06	10,04	X	OK
5	Holes Ø 10	mm	-	16,01	16,04	16,06	15,97	16,03	X	OK
6	Quote 16 (l)	mm	-	24,45	24,40	24,50	24,4	24,4	X	OK
7	Quote 24,5 (z)	mm	-	59,52	59,60	59,49	59,62	59,44	X	OK
8	Quote 60 (b)	mm	61 ± 2	61,4	61,6	61,1	60,8	61,5	X	OK
9	Hardness (HRC)	HRC	53 ± 2	52,5	52,1	51,6	53,0	53,2	X	OK
10	Hardness (HRC)	HRC	53 ± 2	52,5	52,1	51,6	53,0	53,2	X	OK
11										
12										
13										
14										
15										
16										
Peso del campione Sample weight:			kg.	0,218						

Da compilare a cura di / To be filled by ISB

1. Deviazione Deviation n.:	Decisioni Decisions	Approvato Approve					Respiro Fail					Deroga Deviate
		Articolo 1 Piece	Articolo 2 Piece	Articolo 3 Piece	Articolo 4 Piece	Articolo 5 Piece	Articolo 1 Piece	Articolo 2 Piece	Articolo 3 Piece	Articolo 4 Piece	Articolo 5 Piece	
1.	Dimensioni Dimensions	X	X	X	X	X						
2.	Laboratorio Laboratory											
3.	Funzionalità Functionality											
4.	Aspetto Appearance	X	X	X	X	X						

Commenti Notes
All samples comply to the requirements.
Final acceptance is given.

Data Date: **13/09/2010**
Firma Signature: **Quality Control**

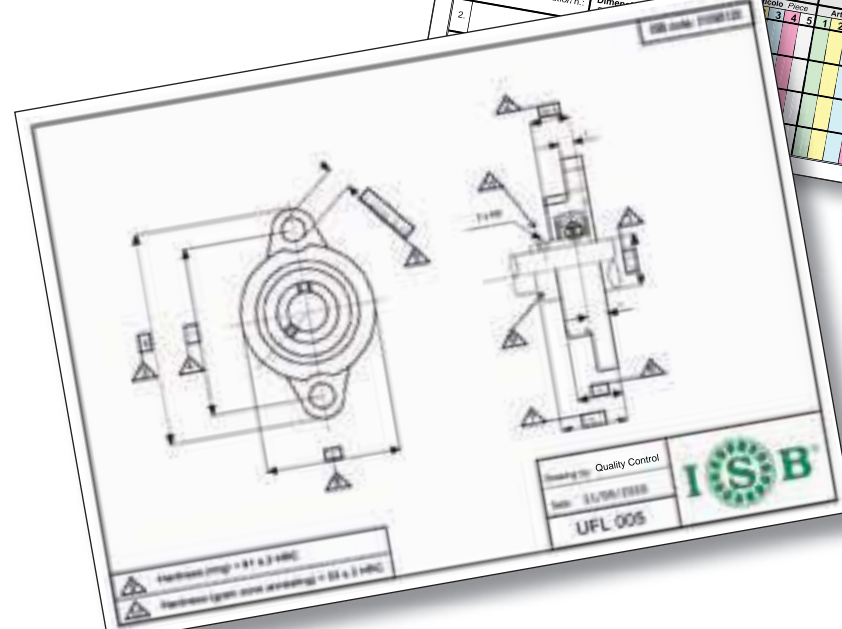

AGRICOLTURA
CASA
INDUSTRIA
MACCHINARI
TEMPO LIBERO
UFFICIO
VEICOLI

AGRICULTURE
HOME
INDUSTRY
MACHINERIES
FREE TIME
OFFICE
VEHICLES



Le numerose linee di cuscinetti e componenti **ISB®** consentono di soddisfare le esigenze nei più svariati settori applicativi. L'ampia gamma e la qualità dei prodotti è tale da garantire applicazioni anche in condizioni d'impiego gravose. I cuscinetti e componenti **ISB®** vantano una produzione articolata e completa di tutte le tipologie, indicata pertanto a soddisfare le più svariate esigenze applicative.

*The diverse product lines of **ISB®** bearings and components make it possible to satisfy the needs of a wide variety of fields of application. The wide range and quality of products is also a guarantee for heavy duty applications. **ISB®** bearings and components are available in versions across-the-board and can meet the requirements of a wide variety of demanding applications.*



CUSCINETTI
BEARINGS



CUSCINETTI PER APPLICAZIONI
"BASSA RUMOROSITÀ"
BEARINGS FOR "LOW NOISE"
APPLICATIONS



CUSCINETTI DI SUPER PRECISIONE
SUPER PRECISION BEARINGS



CUSCINETTI A RULLINI
NEEDLE BEARINGS



CUSCINETTI DI BASE
SLEWING BEARINGS



SUPPORTI AUTOALLINEANTI
SELF-ALIGNING BEARING UNITS



SNODI SFERICI
TESTE A SNODO - FORCELLE
SPHERICAL PLAIN BEARINGS
ROD ENDS - CLEVISES



BOCCOLE
BUSHES



COMPONENTI PER LA
MOVIMENTAZIONE LINEARE
COMPONENTS FOR LINEAR MOTION



RUOTE LIBERE
FREE WHEELS



SFERE PORTANTI - SFERE DI PRECISIONE
RULLI E RULLINI DI PRECISIONE
BALL TRANSFER UNITS
PRECISION BALLS
PRECISION ROLLERS AND NEEDLES



CUSCINETTI DI GRANDI DIMENSIONI
LARGE BEARINGS



CUSCINETTI A SFERE IN
MATERIALI POLIMERICI
POLYMERIC BALL BEARINGS



CUSCINETTI BONDERIZZATI
PER ALTE TEMPERATURE
BONDERIZED BEARINGS FOR
HIGH TEMPERATURES



ANELLI DI TENUTA METALLICI
PER CUSCINETTI
METALLIC SEALS FOR BEARINGS



PRODOTTI IN ACCIAIO INOX
STAINLESS STEEL PRODUCTS

	Titolo Title	Pag. Page
1.	Struttura supporti - Structure of bearing units	1
1.1	ISB® marchio sinonimo di qualità - ISB® is a trademark which identifies quality	2
2.	Caratteristiche tecniche costruttive - Technical constructive characteristics	2
2.1	Materiale dei cuscinetti - Bearing material	3
2.2	Materiale delle gabbie e dei rivetti - Cages and rivets material	4
2.3	Materiale del corpo - Housing material	4
2.4	Materiali degli altri componenti - Other components material	5
2.5	Tenute e protezioni - Seals and covers	6
3.	Tolleranze e simboli - Symbols and tolerances	6
3.1	Tolleranze del diametro dell'alloggiamento - Tolerance of spherical bore diameter of housings	9
3.2	Tolleranze dei supporti ritri - Bearing units tolerances	10
3.3	Tolleranze dei supporti flangiati - Flange bearing units tolerances	11
3.4	Tolleranze dei supporti scorrevoli ed a cartuccia - Take-up and cylindrical cartridge bearing units tolerances	12
3.5	Tolleranze degli alberi - Shafts tolerances	13
3.6	Precisione dimensionale delle fusioni - Dimensional accuracies of castings	14
3.7	Tolleranze delle fusioni - Castings tolerances	14
3.8	Carico ammissibile dei supporti - Allowed load of bearing units	15
3.9	Carico ammissibile dei supporti in lamiera stampata - Allowed load of pressed steel housings	16
3.10	Coefficiente di sicurezza - Safety factor	16
3.11	Velocità massima (giri al minuto) - Max rpm.	17
4.	Coefficienti di carico e durata - Load ratings and life	17
4.1	Coefficiente di carico statico C_0 - Static load ratings C_0	20
4.2	Coefficiente di sicurezza statico S_0 - Static load safety factor S_0	20
4.3	Carico radiale dinamico e statico equivalente - Equivalent radial dynamic and static load	21
5.	Gioco dei cuscinetti a sfere - Clearance of ball bearings	21
5.1	Tipologia giuoco radiale - Types of radial clearance	22
6.	Lubrificazione - Lubrication	24
6.1	Supporti esenti da manutenzione - Maintenance-free bearing units	24
6.2	Supporti ri-lubrificabili - Re-greaseable bearing units	25
6.3	Periodicità della lubrificazione - Periodicity of lubrication	25
6.4	Accorgimenti per la lubrificazione - Rules for lubrication	26
6.5	Quantità di grasso - Grease quantity	27
6.6	Ingrassatori - Grease nipple	28
6.7	Tabella dei lubrificanti - Tables of lubricants	29
7.	Montaggio e smontaggio - Mounting and disassembly	30
7.1	Fissaggio con grani - Setscrews fixing	31
7.2	Fissaggio con bussola di trazione - Taper adapter fixing	32
7.3	Fissaggio con anello eccentrico di serraggio - Eccentric collar locking fixing	33
7.4	Movimento assiale dovuto all'espansione o al restringimento - Axial movement due to expansion and shrinkage	34
7.5	Smontaggio del supporto - Disassembly of bearing unit	35
7.6	Sostituzione del cuscinetto - Bearing replacement	35
8.	Tabella conversione durezza - Conversion table of hardness	36
9.	Tabella conversione pollici/millimetri - Conversion table of inch/millimetres	37
10.	Tabella d'intercambiabilità - Interchangeability table	38
11.	Tipologia dei supporti e cuscinetti ISB® - ISB® Bearing units and bearings type	40
12.	Indice generale dei prodotti ISB® - ISB® Products general index	41
13.	Supporti per alta temperatura - Bearing units for high temperature	42



Ingrassatore per lubrificazione

Grease nipple for lubrication

Doppia tenuta: lamierino di protezione più tenuta in gomma

Double protection: combination of steel and rubber seal

Foro di fissaggio del supporto

Self-aligning bearing units fixing hole

Superficie sferica orientabile

Self-aligning surface

Grano di fissaggio fornibile anche con bussola o collare eccentrico di fissaggio

Set screw fixing also available with eccentric collar or tapered adapter sleeve

Corona a un giro di sfere

Single row deep groove ball bearing

Supporto monoblocco in ghisa

One-piece cast iron housing

Anello interno temperato e rettificato

Hardened ground inner ring

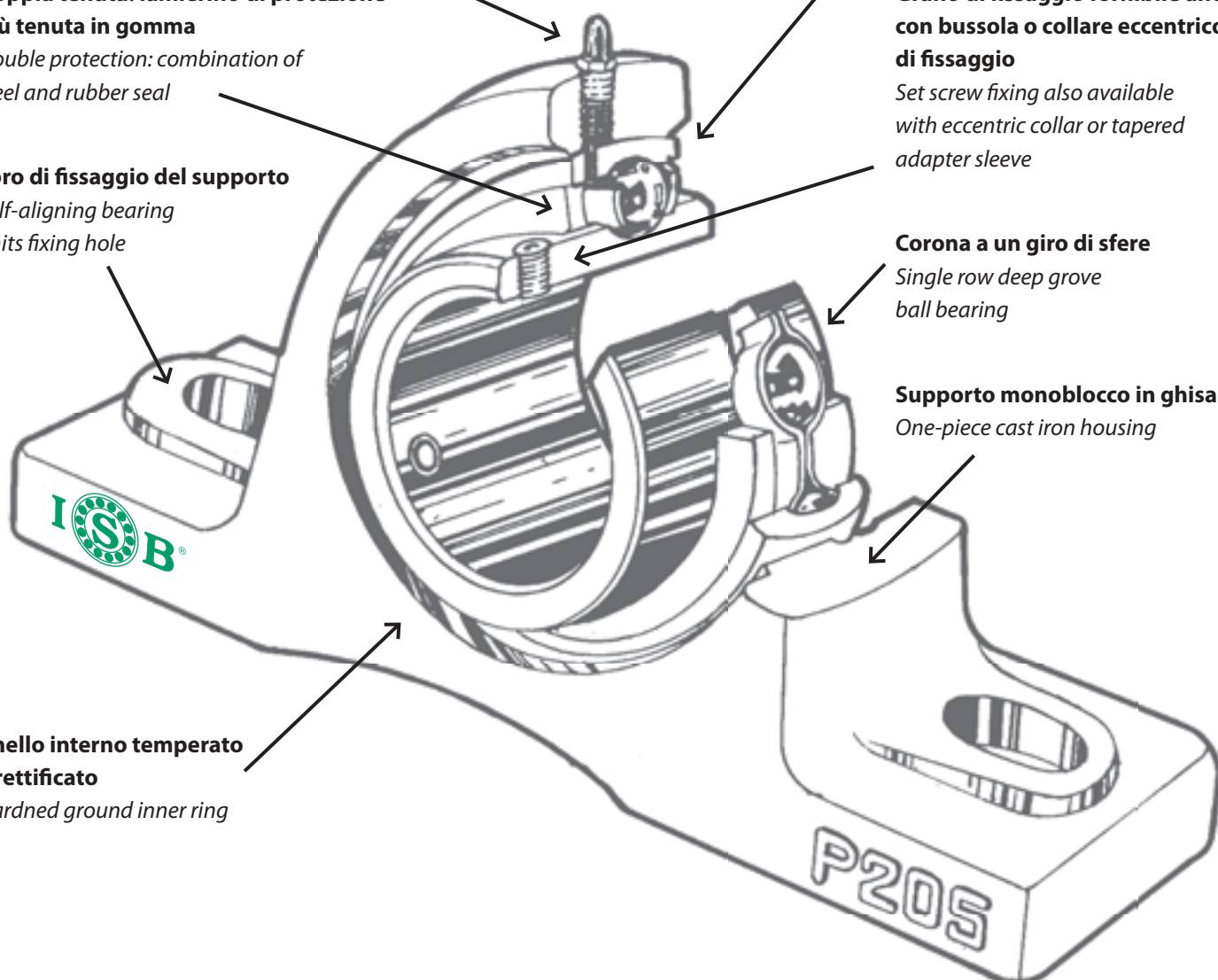

Il marchio **ISB®**, rappresenta una gamma d'articoli tecnici la cui produzione viene affidata ad un pool di costruttori, che hanno saputo mettere a frutto l'esperienza maturata da ormai diversi decenni nel settore. L'elevato know-how tecnico insieme ad apparecchiature d'alto livello sono in grado di garantire una produzione con standard di qualità elevati, sia per ciò che concerne le fasi di produzione, che il controllo dei prodotti finiti. All'interno di questo catalogo tecnico viene illustrata la gamma dei prodotti; inoltre si ricorda che per applicazioni speciali è possibile contattare l'ufficio tecnico.

Lo scopo principale di questo catalogo tecnico è di aiutare i progettisti, cercando di fornire loro le informazioni necessarie per trovare le migliori applicazioni e soluzioni possibili per ciò che riguarda le attività di loro competenza.

La prima parte del catalogo tecnico, illustra le caratteristiche tecniche generali di tutti i supporti in ghisa e dei cuscinetti **ISB®** (caratteristiche costruttive, tolleranze, coefficienti di carico e durata, giuoco del cuscinetto, lubrificazione, ed altre informazioni di vario genere), a seguito vengono indicate le tabelle dimensionali dei prodotti. Nella seconda parte del catalogo, sono illustrate le caratteristiche e le tabelle dimensionali dei supporti della serie pesante, dopodiché nella terza parte si passerà ai supporti in plastica.

Tutte le caratteristiche tecniche di costruzione, sono in accordo con le norme ISO e DIN, questo per garantire un prodotto d'elevata qualità, che mantenga le medesime caratteristiche nel tempo e che sia intercambiabile con i marchi più prestigiosi a livello mondiale.

*The **ISB®** trademark represents a range of technical articles, the production of which is entrusted to a pool of constructors who, exploit their several decades of experience in the sector. High level technical know-how together with advanced equipment guarantee elevated production standards both in the productive phase as well as the quality control phase on the finished product. This technical catalogue illustrates our range of products; though special applications are possible by contacting our technical office as well.*

The principal objective of this technical catalogue is to help project managers by furnishing them with the necessary information to find the best applications and solutions possible for the activity of their competence.

*The first part of this technical catalogue illustrates the general technical characteristics of all the housings in cast iron and the **ISB®** ball bearings (constructive characteristics, tolerances, load and duration coefficients, clearance of the ball bearing, lubrication and various other general information), followed by tables with the sizes of the products. In the second part of the catalogue the characteristics are illustrated in the tables the sizes of the heavy series housings are listed, after which is the third part which moves to the plastic housings.*

All of the technical characteristics of construction are in accordance with ISO and DIN rules, in order to guarantee an elevated product which maintains the same characteristics over time and is interchangeable with more well known brands on a world wide level.

I supporti **ISB®** sono costruiti in molteplici esecuzioni, con corpo esterno in ghisa, in lega d'alluminio, in lamiera d'acciaio stampato ed in plastica. I supporti sono forniti completi di cuscinetto, dotato di anello esterno sferico che può oscillare nella corrispondente pista ricavata nel supporto, in modo tale da compensare qualsiasi difetto d'allineamento, eliminando le sollecitazioni tra albero e supporto. Il cuscinetto inserito nell'alloggiamento del supporto, è corrispondente per le sue caratteristiche costruttive interne ai cuscinetti della serie 62 o 63 secondo le tabelle ISO.

***ISB®** housings are constructed in multiple executions, with external parts in cast iron, bound with aluminium, in moulded steel sheets and in plastic.*

The housing units are supplied complete with ball bearing, provided with external ball rings which can oscillate in the corresponding track hollowed out in the casting, in such a way as to compensate for any defect of alignment, eliminating solicitation between the shaft and the prop. It corresponds to the internal constructive characteristics of the 62 or 63 series according to the ISO tables.

Su entrambi i lati del cuscinetto, sono montate delle guarnizioni di tenuta, studiate e particolarmente indicate per garantire una perfetta tenuta ed evitare così eventuali infiltrazioni di polvere, umidità e fluidi di vario genere. Tutti i cuscinetti sono pre-ingrassati e ri-lubrificabili, fatta eccezione per le serie: CB - RB - SA - SB, che sono lubrificati per tutto l'arco della loro vita.

Nel caso che i supporti debbano essere utilizzati in condizioni particolarmente critiche, come in ambienti dove operano aziende agricole, siderurgiche, fonderie, tutti i supporti possono essere forniti di coperchi di protezione supplementare. I coperchi possono essere costruiti in ghisa grigia o in lamiera d'acciaio o in plastica e sono costituiti in modo tale da garantire anche un'eventuale sostituzione delle tenute in gomma, con comuni anelli in feltro. Esistono anche dei coperchi chiusi, utilizzabili in applicazioni ove l'albero non è passante.

Specially studied and particularly indicated resistance gaskets are located on both sides of the ball bearing, to guarantee perfect resistance, this avoids eventual infiltration from dust, humidity and fluids of various types.

All of the ball bearings are pre-lubricated and can be lubricated repeatedly, except the series: CB - RB - SA - SB, which are lubricated for their lifetime.

Should the housing be used in particularly critical conditions such as the ambient where agricultural companies or iron and steel foundries operate, all of the housings can be supplied with supplementary protective covers.

The covers can be constructed in grey cast iron or in steel sheets or in plastic and are constructed in such a way as to guarantee even eventual substitution of rubber seals with common felt rings. There are also closed covers used in applications where the shaft does not pass.

2.1

MATERIALE DEI CUSCINETTI

BEARINGS MATERIAL

Il materiale delle piste di rotolamento e delle sfere dei cuscinetti, deve avere la necessaria durezza e mantenere le sotto indicate qualità:

1. elevata resistenza contro ripetuti sforzi, che possono causare fratture per affaticamento della superficie nelle piste di rotolamento, che regolano la vita del cuscinetto.
2. elevata resistenza ed elasticità dei materiali per prevenirne la deformazione, nel momento in cui sono applicati dei forti carichi sulla superficie.
3. elevata resistenza all'abrasione, per contrastare efficacemente l'attrito radente tra gabbia e sfere.
4. elevata resistenza contro rotture causate da urti, guasti e/o avarie per errate applicazioni o montaggi impropri.
5. piccoli cambiamenti che possono avvenire nel tempo, per quanto riguarda le dimensioni e la forma dovuti a sollecitazioni interne o variazioni di struttura.

GCr15 acciaio <JIS G4805> (acciaio con elevato contenuto di carbonio e cromo, per cuscinetti), questa tipologia d'acciaio è in grado di soddisfare quanto riportato nei punti precedenti, e la sua composizione chimica viene mostrata nella tabella che segue.

The materials used to construct the rolling track and the bearing spheres must have the necessary hardness and maintain the qualities indicated below:

1. *elevated resistance against repeated straining that can cause fractures due to wear and tear on the surface of the rolling track which regulates the life of the bearing.*
2. *elevated resistance and elasticity of the materials in order to prevent deformation when heavy loads are applied to the surface.*
3. *elevated resistance to abrasion to effectively contrast against wear and tear between the cage and the sphere.*
4. *elevated resistance against breaking caused by collision, breakage and or breakdown due to incorrect application or improper assemblage.*
5. *small changes which could occur over time due to internal solicitation or structural variations.*

GCr15 steel <JIS G4805> (steel with and elevated carbon or chrome content for bearings), is type of steel which is capable of satisfying all of the above points and the chemical composition is shown in the following table.

Composizione chimica dell'acciaio con elevato contenuto di carbonio e cromo per cuscinetti
Chemical composition of high carbon chromium bearing steel

Classificazione <i>Class</i>	Simboli <i>Symbols</i>	Carbonio <i>Carbon</i>	Silicio <i>Silicon</i>	Manganese <i>Manganese</i>	Fosforo <i>Phosphorus</i>	Zolfo <i>Sulphur</i>	Cromo <i>Chromium</i>
	JIS	C	Si	Mn	P	S	JIS
1	SUJ 1	0,95 ~ 1,10	0,15 ~ 0,35	> 0,50	> 0,025	> 0,025	0,90 ~ 1,20
2	SUJ 2	0,95 ~ 1,10	0,15 ~ 0,35	> 0,50	> 0,025	> 0,025	1,30 ~ 1,60
3	SUJ 3	0,95 ~ 1,10	0,40 ~ 0,70	0,90 ~ 1,15	> 0,025	> 0,025	0,90 ~ 1,20

Per mantenere costante la qualità nel tempo, vengono effettuati tutta una serie di controlli sotto riportati:

- analisi chimiche sulla composizione
- esplorazioni magnetiche
- prove di rumorosità e vibrazione
- corrosione da contatto con sostanze acide
- controlli visivi
- controlli della struttura al microscopio
- test di durezza dei materiali
- prove d'affaticamento

In order to maintain the quality constant over time, the entire series of tests reported below are performed:

- *chemical analysis of the composition.*
- *magnetic exploration*
- *noise and vibration tests*
- *corrosion from contact with acid substances.*
- *visual inspection*
- *microscopic inspection*
- *hardness tests on the materials*
- *stress tests*

2.2

MATERIALE DELLE GABBIE E DEI RIVETTI

CAGES AND RIVETS MATERIAL

La composizione del materiale di costruzione delle gabbie è conforme alle norme JIS G 3141; le gabbie sono costituite da lamine d'acciaio al carbonio rullato, raffreddato e pressato SPCC.

La composizione del materiale di costruzione dei rivetti è conforme alle norme JIS G 3507, filetti metallici d'acciaio al carbonio SWRCH 12A.

The composition of the material used to construct the cages conforms to JIS G 3141 norms; the cages are constructed with carbon rolled steel sheets, cooled and pressed SPCC.

The composition of the material used to construct the rivets conforms to JIS G 3507 norms, metal threads of carbon steel SWRCH 12A.

2.3

MATERIALE DEL CORPO

HOUSING MATERIAL

La composizione del materiale di costruzione delle fusioni dei supporti è HT 200 JIS G 5501 (ghisa) e le proprietà meccaniche sono illustrate nella tabella che segue:

The composition of the construction material used to fuse the housings is HT 200 JIS G 5501 (cast iron), the mechanical properties of which are illustrated in the following table:

Proprietà meccaniche delle fusioni in ghisa HT200 - *Mechanical properties of cast iron HT 200*

Classificazione Class	Spessore Thickness	Diametro della barra di prova Diameter of testing bar	Test di tensione Tension test	Test di frenatura laterale Traverse breaking test		Resistenza alla pressione Pressure strength	Test di durezza Hardness test
			Forza di tensione Tensile strenght	Forza di curvatura Bender strength	Deviazione Deflection		
	mm	mm	Kgf/mm ²	Kgf/mm ²	mm	Kgf/mm ²	HB
HT 200 JIS (FC 200)	< 06-80	13	< 32	53	1,8	75	187-255
	< 08-15	20	< 25	45	2,5	75	170-241
	< 15-30	30	< 20	40	2,5	75	170-241
	< 30-50	45	< 18	34	3,0	75	170-241
	< 50	60	< 16	31	4,5	75	160-229

2.4

MATERIALI DEGLI ALTRI COMPONENTI

OTHER COMPONENTS MATERIAL

Nella sotto indicata tabella vengono indicati quelli che sono i principali materiali utilizzati nella costruzione dei principali accessori relativi ai supporti.

The principle materials used to construct the main accessories relative to the housings are indicated in the table below.

Componenti Components	Materiale utilizzato Material used	Simboli JIS JIS symbols	Numeri JIS JIS numbers
Bussola Adapter sleeve	Acciaio al carbonio Carbon steel	S25C	JIS G 4051
Dado Nut	Acciaio al carbonio Carbon steel	S25C	JIS G 4051
Rosetta Washer	Lamine d'acciaio al carbonio rullate a freddo e pressate Cold roller carbon steel sheet and strip	SPCC	JIS G 3141
Anello di tenuta Shaft seal	Gomma nitrilica sintetica Synthetic nitrile rubber	-	-
Dispositivo di lubrificazione Slinger	Lamine d'acciaio al carbonio rullate a freddo e pressate Cold roller carbon steel sheet and strip	SPCC	JIS G 3141
Vite esagonale Hexagon set screw	Acciaio nichelato con cromo e molibdeno Nickel chromium molybdenum steel	SCM 435	JIS G 4105
Chiave esagonale Hexagon wrench key	Acciaio nichelato con cromo e molibdeno Nickel chromium molybdenum steel	SNCM 630	JIS G 4103
Ingrassatore Grease nipple	Ottone Brass	C 3604	JIS H 3250

I cuscinetti utilizzati nei supporti **ISB®** prevedono un sistema di tenuta su entrambi i lati, costituito dalla combinazione di una tenuta in gomma sintetica fissata sull'anello esterno, rinforzata in acciaio e con relativo labbro; mentre sull'anello interno viene fissato uno schermo che ruota insieme all'anello interno stesso. Questo sistema di protezione previene la fuoriuscita di grasso e l'infiltrazione d'agenti inquinanti. Oltre a quanto sopra riportato e come accennato brevemente al punto 2, possono essere utilizzati ulteriori dispositivi di protezione, come i coperchi. L'utilizzo in sinergia di entrambi i dispositivi di protezione è particolarmente indicato in quei casi dove si è in presenza di agenti esterni particolarmente aggressivi, polvere, liquidi vari o quando l'impiego avviene in ambiente esterno.

*The bearings used in **ISB®** housings provide a sealing system on both sides.*

They are constructed with a seal which has synthetic rubber fixed to the external ring and is reinforced with the relative steel lip; while fixed on the inner ring there is a shield which turns together. This protective system prevents grease from exiting and pollutants from entering.

In addition to what is reported above and as briefly mentioned in point n°2., ulterior protection devices such as covers are available. Both protection devices used at the same time is indicated in cases where the external agents are particularly aggressive such as dust, various liquids or for external use.

Le tolleranze dei cuscinetti e dei supporti sono state normalizzate a livello sia nazionale che internazionale in conformità alle norme JIS. I cuscinetti vengono in genere costruiti in classe di tolleranza standard

The tolerances of the bearings and their housings have been normalized at both national and international levels and conform to JIS norms. Generally, the bearings are constructed according to standard tolerances.

d	diametro nominale del foro <i>nominal bore diameter</i>
Δd_{mp}	scostamento del diametro del foro dal valore nominale <i>deviation of bore diameter from nominal value</i>
V_{dp}	variazione del diametro del foro <i>bore diameter variation</i>
D	diametro nominale esterno <i>nominal outer diameter</i>
ΔD_{mp}	scostamento del diametro esterno medio dal valore nominale <i>deviation of the mean outer diameter from nominal value</i>
K_{ia}	concentricità di rotazione dell'anello interno nel cuscinetto completo (precisione radiale di rotazione) <i>concentricity radial run out of assembled bearing inner ring (run out radial precision)</i>
K_{ea}	concentricità di rotazione dell'anello esterno nel cuscinetto completo (precisione radiale di rotazione) <i>concentricity radial run out of assembled bearing outer ring (run out radial precision)</i>
ΔB_s	scostamento di una singola misura dell'altezza dell'anello interno rispetto alla dimensione nominale <i>inner ring single height deviation as regards to nominal dimension</i>
ΔC_s	scostamento di una singola misura dell'altezza dell'anello esterno rispetto alla dimensione nominale <i>outer ring single height deviation as regards to nominal dimension</i>

Anello interno - Inner ring

Diametro interno (d) Inner diameter (d)				Tipo (cuscinetto con foro cilindrico) Type (cylindrical bore bearing) UC - HC - SA - SB - SER				Scostamento altezza Height deviation				Concentricità di rotazione Concentricity radial run out			
Oltre Over		Fino a Up to		Δd_{mp}				V_{dp}		ΔB_s				K_{ia}	
mm	pollici inch	mm	pollici inch	max	min	max	min	max		min	max	min	max	max	
10	0,3937	18	0,7087	+15	0	+6	0	10	4	0	-120	0	-47	15	6
18	0,7087	30	1,1811	+18	0	+7	0	12	5	0	-120	0	-47	18	7
30	1,1811	50	1,9685	+21	0	+8	0	14	6	0	-120	0	-47	20	8
50	1,9685	80	3,1496	+24	0	+9	0	16	6	0	-150	0	-59	25	10
80	3,1496	120	4,7244	+28	0	+11	0	19	7	0	-200	0	-79	30	12
120	4,7244	180	7,0866	+33	0	+13	0	22	9	0	-250	0	-98	35	14

Anello interno - Inner ring

Diametro interno (d) Inner diameter (d)				Tipo (cuscinetto con foro cilindrico) Type (cylindrical bore bearing) CB				Scostamento altezza Height deviation				Concentricità di rotazione Concentricity radial run out			
Oltre Over		Fino a Up to		Δd_{mp}				V_{dp}		ΔB_s				K_{ia}	
mm	pollici inch	mm	pollici inch	max	min	max	min	max		min	max	min	max	max	
10	0,3937	18	0,7087	0	-8	0	-3	10	4	0	-120	0	-47	15	6
18	0,7087	30	1,1811	0	-10	0	-4	12	5	0	-120	0	-47	18	7
30	1,1811	50	1,9685	0	-12	0	-5	14	6	0	-120	0	-47	20	8

Anello esterno - Outer ring

Diametro esterno (d) Outer diameter (d)				Scostamento del diametro esterno medio Deviation of the mean outer diameter				Scostamento altezza Height deviation				Concentricità di rotazione Concentricity radial run out	
Oltre Over		Fino a Up to		ΔD_{mp}				ΔC_s				K_{ea}	
mm	pollici inch	mm	pollici inch	max	min	max	min	min	max	min	max	max	
18	0,7087	30	1,1811	0	-9	0	-4	0	-120	0	-47	15	6
30	1,1181	50	1,9685	0	-11	0	-4	0	-120	0	-47	20	8
50	1,9685	80	3,1496	0	-13	0	-5	0	-150	0	-59	25	10
80	3,1496	120	4,7244	0	-15	0	-6	0	-200	0	-79	35	14
120	4,7244	150	5,9055	0	-18	0	-7	0	-250	0	-98	40	16
150	5,9055	180	7,0866	0	-25	0	-10	0	-250	0	-98	45	18
180	7,0866	250	9,8425	0	-30	0	-12	0	-300	0	-118	50	20
250	9,8425	315	12,4016	0	-35	0	-14	0	-350	0	-137	60	24

Semiangolo del cono: α

Half angle of cone: α

$$\alpha = 2^{\circ}23'9,4''$$

$$= 2.38594^{\circ}$$

$$= 0.041643 \text{ rad}$$

(conicità 1:12)

(taper-ratio 1:12)

Diametro maggiore teorico d_1 :

Theoretical bigger diameter d_1 :

$$d_1 = d + \frac{1}{12}B \quad \begin{matrix} \text{(conicità 1:12)} \\ \text{(taper-ratio 1:12)} \end{matrix}$$

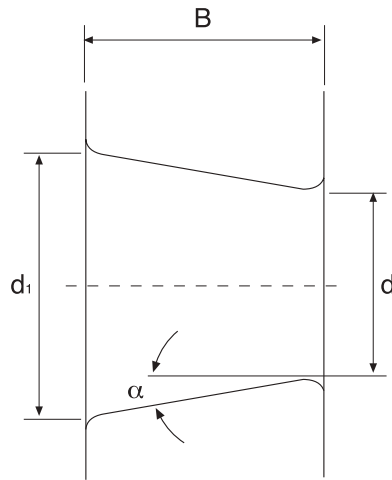

Foro conico teorico
Theoretical bore diameter

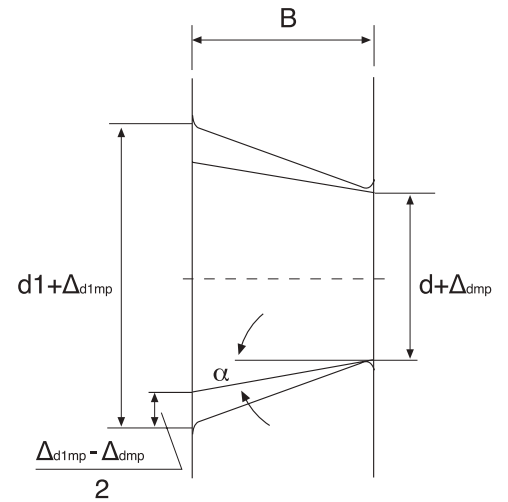

Foro conico con uno scostamento nella dimensione del diametro medio nella superficie piana
Conical bore with deviation of mean diameter in flat surface

Δd_{mp}	Scostamento nella dimensione del diametro medio del foro nella superficie piana all'estremità minore teorica del foro conico Deviation of mean bore diameter in a single plane (for a basically bore, Δd_{mp} refers to the theoretical small end of the conical bore)
Δd_{1mp}	Scostamento nella dimensione del diametro medio del foro nella superficie piana all'estremità maggiore teorica del foro conico Deviation of mean bore diameter in a single plane at the theoretical large end of a basically conical bore)
V_{dp}	Variatione del diametro del foro Bore diameter variation
V_{dp}	Altezza dell'anello interno Inner ring height

Anello interno (foro conico) - Inner ring (conical bore)

Diametro interno (d) Inner diameter (d)				$+\Delta d_{mp}$				$\Delta d_{1mp} - \Delta d_{mp}$				$V_{dp}^{1)}$	
Oltre Over		Fino a Up to		max	min	max	min	min	max	min	max	max	
mm	pollici inch	mm	pollici inch										
18	0,7087	30	1,1811	+21	0	+8	0	+21	0	+8	0	13	5
30	1,1811	50	1,9685	+25	0	+10	0	+25	0	+10	0	15	6
50	1,9685	80	3,1496	+30	0	+12	0	+30	0	+12	0	19	7
80	3,1496	120	4,7244	+35	0	+14	0	+35	0	+14	0	25	10
120	4,7244	180	7,0866	+40	0	+16	0	+40	0	+16	0	31	12

1) Valido in ogni singolo piano radiale del foro - Valid for every radial flat of bore.

Tolleranza della distanza (n) dalla linea centrale dell'anello esterno sferico all'anello interno
Tolerance in distance (n) from centre line of spherical outer ring to side of inner ring

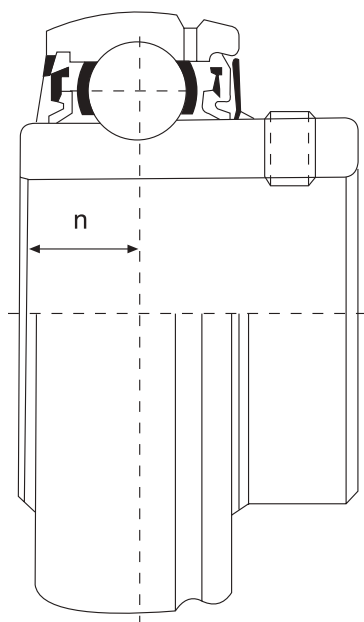

Diametro interno (d) <i>Inner diameter (d)</i>				Tolleranza (n) <i>Tolerance (n)</i>	
Oltre <i>Over</i>		Fino a <i>Up to</i>			
mm	pollici <i>inch</i>	mm	pollici <i>inch</i>		
2,5	0,0984	50	1,9685	±200	±79
50	1,9685	80	3,1496	±250	±98
80	3,1496	120	4,7244	±300	±118
120	4,7244	-	-	±350	±138

3.1

TOLLERANZE DEL DIAMETRO DELL'ALLOGGIAMENTO

TOLERANCE OF SPHERICAL BORE DIAMETER OF HOUSING

Diametro del foro sferico del supporto
Spherical bore diameter of bearing units

Diametro del foro sferico (D _s) <i>Spherical bore diameter (D_s)</i>				Scostamento del diametro medio del foro (^Δ D _{am}) <i>Mean bore diameter deviation (^ΔD_{am})</i>											
Oltre <i>Over</i>		Fino a <i>Up to</i>		Tolleranza H7 <i>H7 tolerance</i>				Tolleranza J7 <i>J7 tolerance</i>				Tolleranza K <i>K tolerance</i>			
mm	pollici <i>inch</i>	mm	pollici <i>inch</i>	min	max	min	max	min	max	min	max	min	max	min	max
30	1,1811	50	1,9685	+25	0	+10	0	+14	-11	+6	-4	+7	-18	+3	-7
50	1,9685	80	3,1496	+30	0	+12	0	+18	-12	+7	-5	+9	-21	+4	-8
80	3,1496	120	4,7244	+35	0	+14	0	+22	-13	+9	-5	+10	-25	+4	-10
120	4,7244	180	7,0866	+40	0	+16	0	+26	-14	+10	-6	+12	-28	+5	-11
180	7,0866	250	9,8425	+46	0	+18	0	+30	-16	+12	-6	+13	-33	+5	-13
250	9,8425	315	12,4016	+52	0	+20	0	+36	-16	+14	-6	-	-	-	-

Tipologia dei supporti ritri <i>Bearing units type</i>						Tolleranza h <i>Tolerance h</i>
P203	-	-	-	-	-	±150
P204	-	-	HP204	UP204	PL204	
P205	P305	PX05	HP205	UP205	PL205	
P206	P306	PX06	HP206	UP206	PL206	
P207	P307	PX07	HP207	UP207	PL207	
P208	P308	PX08	HP208	UP208	-	
P209	P309	PX09	HP209	UP209	PL209	
P210	P310	PX10	HP210	UP210	PL210	
P211	P311	PX11	-	-	-	
P212	P312	PX12	-	-	-	
P231	P313	PX13	-	-	-	
P214	P314	PX14	-	-	-	
P215	P315	PX15	-	-	-	
P216	P316	PX16	-	-	-	
P217	P317	PX17	-	-	-	
P218	P318	PX18	-	-	-	
-	P319	-	-	-	-	±300
-	P320	PX20	-	-	-	
-	P321	-	-	-	-	
-	P322	-	-	-	-	
-	P324	-	-	-	-	
-	P326	-	-	-	-	
-	P328	-	-	-	-	

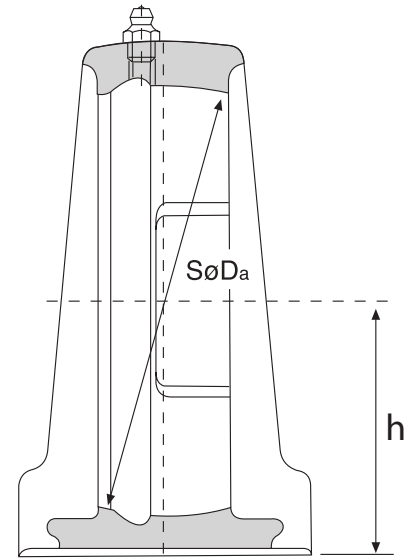

3.3

TOLLERANZE DEI SUPPORTI FLANGIATI

FLANGE BEARING UNITS TOLERANCES

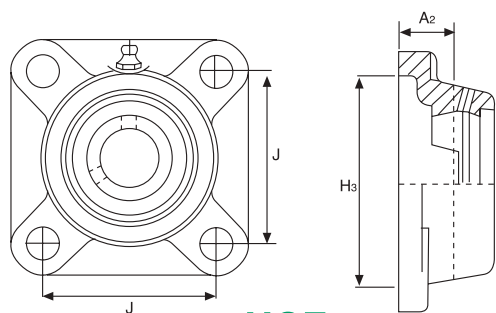

UCF

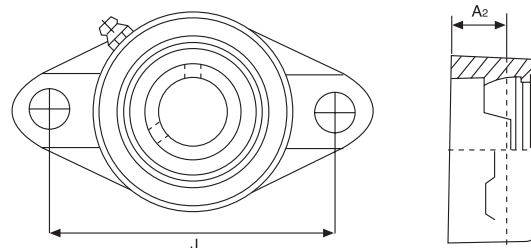

UCFL

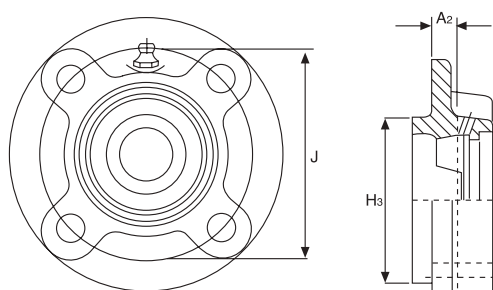

UCFC

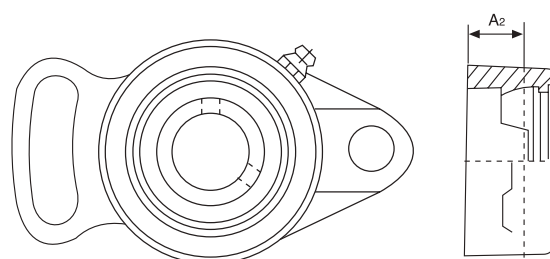

UCFA

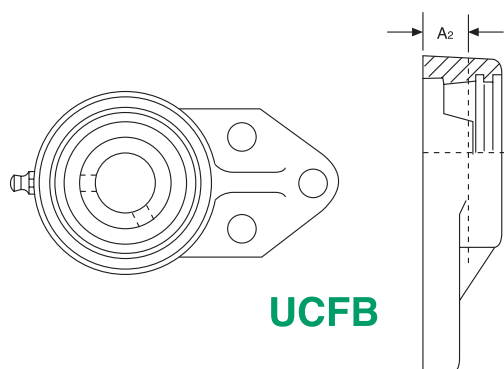

UCFB

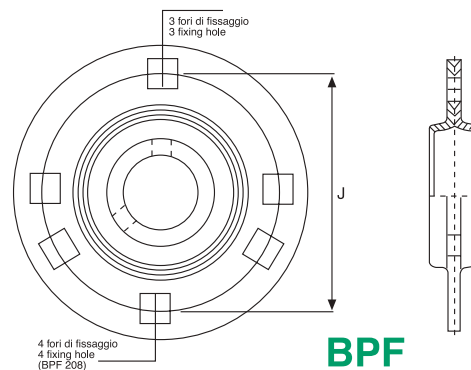

BPF

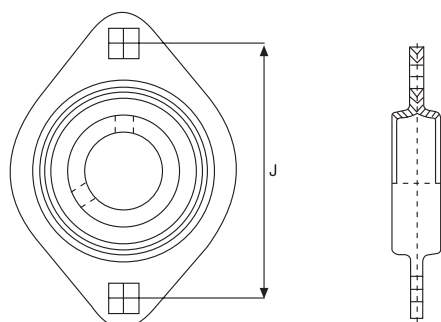

BPFL

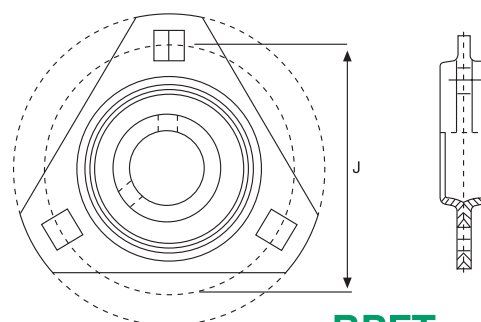

BPFT

Tipologia dei supporti flangiati Flange bearing units type							Tolleranza J Tolerance		Tolleranza A₂ Tolerance		Spostamenti H ₃ H ₃ deviation								Tolleranza A₂ Tolerance					
											FC2				FCX						FS3			
											max	min	max	min	max	min	max	min			max	min	max	min
F2...	F3...	FX...	FC2...	FS3...	FL2...	FL3...	±700	±276	±500	±197	-	-	-	-	-	-	-	-	200	79				
F204	-	-	FC204	-	FL204	-					0	-46	0	-18	0	-46	0	-18			0	-46	0	-18
F205	F305	FX05	FC205	FS305	FL205	FL305					0	-54	0	-21	0	-54	0	-21			0	-54	0	-21
F206	F306	FX06	FC206	FS306	FL206	FL306					0	-63	0	-25	0	-63	0	-25			0	-63	0	-25
F207	F307	FX07	FC207	FS307	FL207	FL307					0	-72	0	-28	0	-72	0	-28			0	-72	0	-28
F208	F308	FX08	FC208	FS308	FL208	FL308					-	-	-	-	-	-	-	-			-	-	-	-
F209	F309	FX09	FC209	FS309	FL209	FL309					-	-	-	-	-	-	-	-			-	-	-	-
F210	F310	FX10	FC210	FS310	FL210	FL310					-	-	-	-	-	-	-	-			-	-	-	-
F211	F311	FX11	FC211	FS311	FL211	FL311					-	-	-	-	-	-	-	-			-	-	-	-
F212	F312	FX12	FC212	FS312	FL212	FL312					-	-	-	-	-	-	-	-			-	-	-	-
F213	F313	FX13	FC213	FS313	FL213	FL313	±1000	±394	±800	±315	0	-63	0	-25	0	-63	0	-25	0	-63	0	-25	300	118
F214	F314	FX14	FC214	FS314	FL214	FL314					0	-72	0	-28	0	-72	0	-28	0	-72	0	-28		
F215	F315	FX15	FC215	FS315	FL215	FL315					-	-	-	-	-	-	-	-	-	-	-	-		
F216	F316	FX16	FC216	FS316	FL216	FL316					-	-	-	-	-	-	-	-	-	-	-	-		
F217	F317	FX17	FC217	FS317	FL217	FL317					0	-81	0	-32	0	-81	0	-32	0	-81	0	-32		
F218	F318	FX18	FC218	FS318	FL218	FL318					0	-89	0	-35	0	-89	0	-35	0	-89	0	-35		
-	F319	-	-	FS319	-	FL319					-	-	-	-	-	-	-	-	-	-	-	-		
-	F320	FX20	-	FS320	-	FL320					-	-	-	-	-	-	-	-	-	-	-	-		
-	F321	-	-	FS321	-	FL321					-	-	-	-	-	-	-	-	-	-	-	-		
-	F322	-	-	FS322	-	FL322					-	-	-	-	-	-	-	-	-	-	-	-		
-	F324	-	-	FS324	-	FL324	-	-	-	-	-	-	-	-	-	-	-	-						
-	F326	-	-	FS326	-	FL326	-	-	-	-	-	-	-	-	-	-	-	-						
-	F328	-	-	FS328	-	FL328	-	-	-	-	-	-	-	-	-	-	-	-						

3.4 TOLLERANZE DEI SUPPORTI SCORREVOLI ED A CARTUCCIA TAKE-UP AND CYLINDRICAL CARTRIDGE BEARING UNITS TOLERANCES

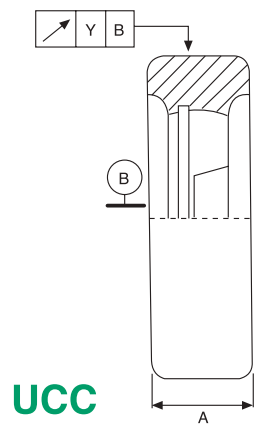
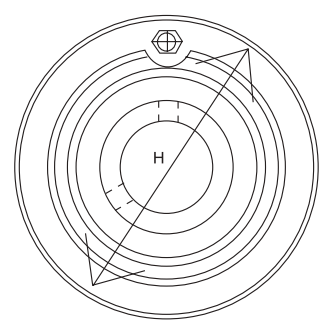
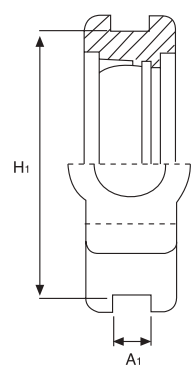
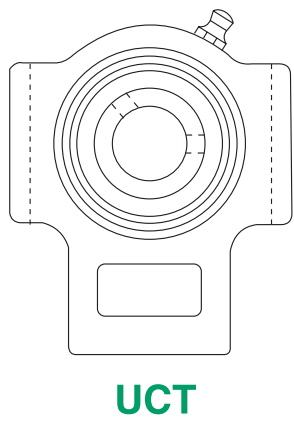

Tipologia dei supporti scorrevoli Take-up bearing units type			Tolleranza A ₁ Tolerance		Tolleranza H ₁ Tolerance		Parallelismo di guida Parallelism of sliding bolt		Tipologia dei supporti a cartuccia Cylindrical cartridge bearing units type			Tolleranza H H Tolerance						Difetto radiale Y Spigot run-out max		Scostamento A Deviation			
			C2...		CX...							C3...											
			max min	max min	max min	max min						max min	max min	max min	max min								
T2...	TX...	T3...							C2...	CX...	C3...												
T204	-	T304							C204	CX204	C304	0	0	-	-	-	-						
T205	TX205	T305	+200 0	+79 0	0 -500	0 -197	500	197	C205	CX205	C305	-30	-12										
T206	TX206	T306							C206	CX206	C306			0	0	0	0	0	0	200	79	±200	±79
T207	TX207	T307							C207	CX207	C307			-35	-14	-35	-14						
T208	TX208	T308							C208	CX208	C308			0	0								
T209	TX209	T309							C209	CX209	C309			-35	-14								
T210	TX210	T310																					
T211	TX211	T311							C211	CX211	C311			0	0								
T212	TX212	T312							C212	CX212	C312	0	0	-40	-16	0	0						
T213	TX213	T313							C213	-	C313	-40	-16										
T214	TX214	T314					600	236	-	-	C314												
T215	TX215	T315							-	-	C315												
T216	TX216	T316							-	-	C316												
T217	TX217	T317							-	-	C317			0	0								
-	-	T318	+300 0	+118 0	0 -800	0 -315			-	-	C318			-46	-18								
-	-	T319										-	-	C319									
-	-	T320											-	-	C320								
-	-	T321									700	276	-	-	C321			0	0				
-	-	T322											-	-	C322			-52	-20				
-	-	T324							-	-	C324												
-	-	T326					800	315	-	-	C326			0	0								
-	-	T328							-	-	C328			-57	-22								

3.5 TOLLERANZE DEGLI ALBERI SHAFTS TOLERANCES

Le tolleranze degli alberi, sono influenzate e determinate principalmente da due fattori; il diametro ed il numero dei giri che devono compiere. Nel caso l'albero preveda un impiego con un numero di giri basso, si possono utilizzare tolleranze h9, mentre nei casi in cui gli alberi devono compiere molti giri è preferibile utilizzare tolleranze più ristrette.

The tolerances of the shafts are influenced and determined mainly by two factors: the diameter and the number of rounds to be completed. Should the shaft require a low number of rounds, the tolerance can be h9, whereas, if the shaft requires a higher number of rounds it is preferable to use a more narrow tolerance.

Tolleranze albero per cuscinetti serie UC - SB - SA
Shaft tolerance for UC - SB - SA bearings series

Dimensione dell'albero (d) Shaft dimension (d)				Tolleranza diametro dell'albero Diameter shaft tolerance							
Oltre/Over		Fino a/Up to		j6		h6		h7		h8	
mm	pollici inch	mm	pollici inch	dn > 120 000		dn ≤ 120 000		dn ≤ 100 000		dn ≤ 60 000	
10	0,3937	18	0,7087	+8 ~ -3	+3 ~ -1	0 ~ -11	0 ~ -4	0 ~ -18	0 ~ -7	0 ~ -27	0 ~ -11
18	0,7087	30	1,1811	+8 ~ -4	+4 ~ -2	0 ~ -13	0 ~ -5	0 ~ -21	0 ~ -8	0 ~ -33	0 ~ -13
30	1,1811	50	1,9685	+11 ~ -5	+4 ~ -2	0 ~ -16	0 ~ -6	0 ~ -25	0 ~ -10	0 ~ -39	0 ~ -15
50	1,9685	80	3,1496	+12 ~ -7	+5 ~ -3	0 ~ -19	0 ~ -7	0 ~ -30	0 ~ -12	0 ~ -46	0 ~ -18
80	3,1496	120	4,7244	+13 ~ -9	+5 ~ -4	0 ~ -22	0 ~ -9	0 ~ -35	0 ~ -14	0 ~ -54	0 ~ -21
120	4,7244	180	7,0866	+14 ~ -11	+6 ~ -4	0 ~ -25	0 ~ -10	0 ~ -40	0 ~ -16	0 ~ -63	0 ~ -25

Tolleranze albero per cuscinetti serie UK
Shaft tolerance for UK bearings series

Dimensione dell'albero (d) Shaft dimension (d)				Tolleranza diametro dell'albero Diameter shaft tolerance							
OltrevOver		Fino a Up to		h8		h9		h10		h11	
mm	pollici inch	mm	pollici inch	Superiore Upper		Inferiore Lower		Superiore Upper		Inferiore Lower	
10	0,3937	18	0,7087	0 - 27	0 - 11	- -	- -	- -	- -	- -	- -
18	0,7087	30	1,1811	0 - 33	0 - 13	0 - 52	0 - 20	0 - 84	0 - 33	0 - 120	0 - 47
30	1,1811	50	1,9685	0 - 39	0 - 15	0 - 62	0 - 24	0 - 100	0 - 39	0 - 160	0 - 63
50	1,9685	80	3,1496	0 - 46	0 - 18	0 - 74	0 - 29	0 - 120	0 - 47	0 - 190	0 - 75
80	3,1496	120	4,7244	0 - 54	0 - 21	0 - 87	0 - 34	0 - 140	0 - 55	0 - 200	0 - 79
120	4,7244	180	7,0866	0 - 63	0 - 25	0 - 100	0 - 39	0 - 160	0 - 63	0 - 250	0 - 98

3.6

PRECISIONE DIMENSIONALE DELLE FUSIONI

DIMENSIONAL ACCURACIES OF CASTINGS

Per conoscere il grado di precisione dimensionale delle fusioni, quando questo valore non è specificato, sarà opportuno far riferimento allo standard **JIS B 0405** (valore che rappresenta lo scostamento medio dimensionale ammissibile, in assenza di valori indicati).

When the dimensional accuracy of the casting is not specified simply refer to the **JIS B 0405** standard (the average deviation admissible in absence of indicated values).

Dimensioni Dimensions				Tolleranza dimensionale della classe media Middle class dimensional tolerance	
Superiore Upper		Incluso Included			
mm	pollici inch	mm	pollici inch		
0,5	0,0197	6	0,2362	±100	±39
6	0,2362	30	1,1811	±200	±79
30	1,1811	120	4,7244	±300	±118
120	4,7244	315	12,4016	±500	±197
315	12,4016	1000	39,3701	±800	±315

3.7

TOLLERANZE DELLE FUSIONI

CASTINGS TOLERANCES

La precisione dimensionale della fusione segue lo standard **JIS B 0407** (scostamento medio delle dimensioni in assenza d'indicazione sulla tolleranza della fusione).

The dimensional accuracy of the castings is done according to **JIS B 0407** (average deviation of the dimensions when the tolerance is absent from the casting).

Tolleranza nella lunghezza <i>Tolerance in length</i>						Tolleranza nello spessore <i>Tolerance in thickness</i>					
Dimensioni <i>Dimensions</i>				Tolleranza <i>Tolerance</i>		Dimensioni <i>Dimensions</i>				Tolleranza <i>Tolerance</i>	
Superiore <i>Over</i>		Incluso <i>Included</i>				Superiore <i>Over</i>		Incluso <i>Included</i>			
mm	pollici <i>inch</i>	mm	pollici <i>inch</i>			mm	pollici <i>inch</i>	mm	pollici <i>inch</i>		
-	-	120	4,7244	±1500	±591	-	-	-	-	-	-
120	4,7244	250	9,8425	±2000	±787	-	-	10	0,3937	±1500	±591
250	9,8425	400	15,7480	±3000	±1181	10	0,3937	18	0,7087	±2000	±787
400	15,7480	800	31,4961	±4000	±1575	18	0,7087	30	1,1811	±3000	±1181
800	31,4961	1600	62,9921	±6000	±2362	30	1,1811	50	1,9685	±3500	±1378

3.8 CARICO AMMISSIBILE DEI SUPPORTI ALLOWED LOAD BEARING UNITS

La capacità di carico dei supporti è determinata principalmente da due fattori:

- la forma
- la direzione del carico.

Visto che ogni supporto ha caratteristiche diverse nella forma, può risultare difficile calcolare le capacità di carico permesse. In tutti i casi è sempre opportuno prestare attenzione sulla direzione della forza applicata, che può essere verso il basso, verso l'alto, orizzontale o assiale.

The housing load is determined principally by two factors:

- *the form*
- *the direction of the load*

As each housing has different characteristics in different forms, it can be difficult to calculate the permitted load capacity. In any case, it is always helpful to consider the direction of the force applied. The direction can be upward, downward, horizontal or axial.

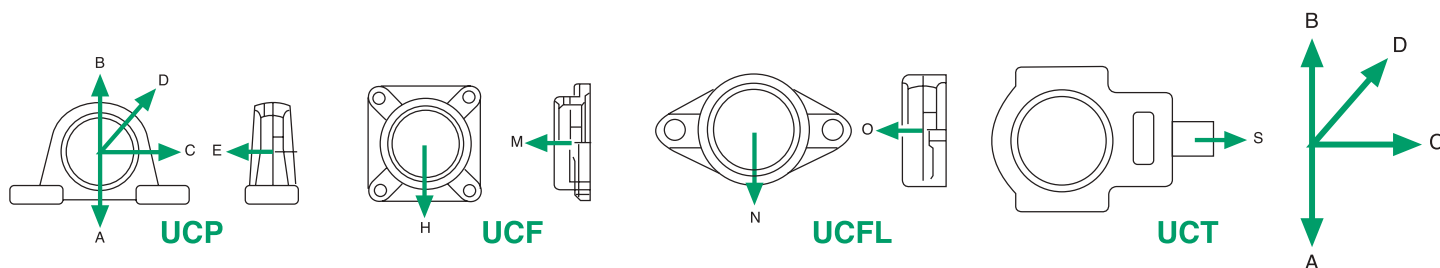

A/H/N Direzione verso il basso
B Direzione verso l'alto
C/S Direzione in orizzontale
D Direzione a 45°
E/M/O Direzione assiale

A/H/N Downward direction
B Upward direction
C/S Horizontal direction
D 45° direction
E/M/O Axial direction

Dimensioni Dimensions	Carico statico di rottura - Static ratings load									
	Tipo - Type					Tipo - Type		Tipo - Type		Tipo - Type
	UCP					UCF		UCFL		UCT
	A	B	C	D	E	H	M	N	O	S
203	69	29	49	22	10	-	-	-	-	-
204	79	32	54	24	16	42	17	23	11	33
205	92	36	59	27	17	65	24	37	15	37
206	117	49	88	34	21	65	29	37	19	40
207	156	59	98	43	23	63	35	40	22	56
208	176	64	107	45	24	69	38	40	26	80
209	186	68	117	48	25	98	46	60	31	76
210	186	73	137	55	31	98	49	60	38	84
211	205	80	147	58	33	90	55	72	43	95
212	274	107	166	71	43	90	60	86	47	98
213	284	117	186	81	49	166	67	96	60	127
214	313	117	196	82	54	186	74	98	68	127
215	323	127	205	90	56	186	78	107	70	127
216	352	147	264	107	64	166	84	127	84	137
217	441	166	274	117	73	205	93	137	92	156
218	470	186	323	127	117	245	107	137	137	-

3.9
CARICO AMMISSIBILE DEI SUPPORTI IN LAMIERA STAMPATA
ALLOWED LOAD OF PRESSED STEEL HOUSINGS

I supporti in lamiera stampata **ISB**® quando vengono sottoposti a dei carichi potrebbero presentare delle deformazioni. Tali deformazioni possono variare a seconda sia della direzione che dall'ammontare del carico stesso, inoltre anche la forma del supporto e lo spessore dei lamierini possono influire sull'entità delle deformazioni.

Da quanto sopra esposto si deduce che il carico ammissibile deve essere tale che la deformazione provocata, non pregiudichi la funzionalità del supporto stesso.

Il carico ammesso sarà approssimativamente 1/3 del valore di carico base in direzione radiale ed 1/3 del carico radiale permesso in direzione assiale.

*When the housings in sheets stamped **ISB**® are subjected to loads, deformations could present themselves. Such deformations may vary according to the direction of the total load itself, furthermore, also the form of the housing or the thickness of the sheet can influence the entity of the deformations. From all of the above we can deduct that the allowable load should be such that the deformation provoked does not prejudice the functionality of the housing itself. The allowable load will be approximately 1/3 of the base load value in a radial direction and 1/3 of the radial load permitted in axial direction*

3.10
COEFFICIENTI DI SICUREZZA
SAFETY FACTOR

Prima dell'impiego di un supporto è necessario determinare l'intensità e la direzione del carico tenendo conto dei relativi fattori di sicurezza. Per stabilire il carico ammissibile bisogna dividere il valore del carico statico di rottura per il fattore di sicurezza.

Before using a housing unit it is necessary to determine the intensity and direction of the load considering the pertinent factor of security. To establish the admissible load it is necessary to divide the value of static load by the security factor.

Condizioni di carico <i>Load conditions</i>	Carico permanente <i>Permanent load</i>	Carico vibratorio <i>Vibratory load</i>	Carico improvviso <i>Unexpected load</i>
Coefficiente di sicurezza <i>Safety factor</i>	4	10	15

3.11 VELOCITÀ MASSIMA (GIRI AL MINUTO)

MAX RPM.

Tipo <i>Type</i>	Diametro <i>Diameter</i>	Tolleranza max. ammissibile n. giri <i>Max rpm.</i>			
		j7	h7	h8	h9
UC-SB	mm				
201	12	6700	5900	4300	1600
202	15	6700	5500	4000	1500
203	17	6700	5300	3800	1400
204	20	6700	4900	3500	1250
205	25	5600	4100	2900	1050
206	30	4700	3400	2400	880
207	35	4000	3000	2100	760
208	40	3600	2600	1900	680
209	45	3300	2400	1700	620
210	50	3000	2200	1600	570
211	55	2700	2000	1400	510
212	60	2400	1800	1250	460
213	65	2300	1700	1150	420
214	70	2200	1600	1100	400
215	75	2000	1500	1000	380
216	80	1900	1400	960	350
217	85	1800	1300	900	330
218	90	1700	1200	840	310
-	-	-	-	-	-
-	-	-	-	-	-
-	-	-	-	-	-

Tipo <i>Type</i>	Diametro <i>Diameter</i>	Tolleranza max. ammissibile n. giri <i>Max rpm.</i>			
		j7	h7	h8	h9
UC-SB	mm				
305	25	5000	3700	2600	940
306	30	4300	3100	2200	800
307	35	3800	2800	2000	720
308	40	3400	2500	1700	640
309	45	3000	2200	1500	560
310	50	2700	2000	1400	500
311	55	2500	1800	1300	470
312	60	2300	1700	1150	430
313	65	2100	1500	1100	400
314	70	2000	1400	1000	370
315	75	1800	1300	930	340
316	80	1700	1250	870	320
317	85	1600	1150	810	300
318	90	1500	1100	760	280
319	95	1400	1000	720	260
320	100	1300	940	660	240
321	105	1250	900	630	230
322	110	1200	830	590	210
324	120	1100	750	530	190
326	130	1000	680	480	180
328	140	900	620	440	160

4 COEFFICIENTI DI CARICO E DURATA

LOAD RATINGS AND LIFE

La durata dei cuscinetti volventi può essere definita come il numero di giri o di ore di funzionamento, che il cuscinetto è in grado di sopportare prima che compaiano i primi segni di fatica su uno degli anelli, sulla pista di rotolamento o sugli elementi volventi. Tali segnali d'affaticamento sono causati da ripetute sollecitazioni, che influenzano i materiali di composizione dei cuscinetti. Vi sono comunque altri fattori che possono influenzare la durata della vita di un cuscinetto, ad esempio, l'abrasione, la corrosione, il grippaggio, l'ossidazione, la ruggine.

The life of rotating bearings can be defined as the number of rounds or by the functioning hours, that the bearing is capable of withstanding before showing the first signs of wear on one of the rings, on the rotating track or on the rotating elements. Such signs of wear are caused by repeated use and are influenced by the composition materials of the bearings.

There are in any case other factors that can influence the life of a bearing; for example, abrasion, corrosion, the binding, oxidation and rust.

Questi tipi di problemi possono presentarsi per eventuali applicazioni non idonee, per un errato montaggio, per insufficiente o non avvenuta lubrificazione. I problemi sopra elencati, sono da considerarsi diversi dal cedimento dei materiali, in quanto potrebbero essere evitati con le dovute precauzioni. Ove si voglia tenere in considerazione solamente la fatica nelle superfici di lavoro del cuscinetto, si dovranno osservare le seguenti condizioni:

1. Le forze e le velocità tenute in considerazione per la valutazione del cuscinetto dovranno corrispondere a quelle riportate alle reali condizioni d'esercizio.
2. Durante l'intero periodo d'esercizio dovrà essere assicurata un'adeguata lubrificazione.
3. L'esperienza dimostra come il cedimento di molti cuscinetti sia da attribuirsi a cause diverse dalla fatica, quali: scelta di un cuscinetto di tipo inadeguato, difetti di funzionamento o di lubrificazione, presenza di particelle estranee nel cuscinetto, od altro.

La durata a fatica nominale di un singolo cuscinetto, o di una campionatura di cuscinetti identici e operanti a identiche condizioni di esercizio, consiste nella durata d'esercizio pari almeno ad un grado di affidabilità del 90%.

La durata media di un gruppo di cuscinetti è di molto superiore alla durata nominale.

La durata a fatica nominale è espressa con L_{10} (milioni di giri - coefficiente di carico dinamico) o L_{10h} (ore d'esercizio). La sotto indicata equazione, permette di calcolare la relazione tra la durata nominale, il coefficiente di carico dinamico ed il carico agente sul cuscinetto:

$$L_{10} = \left(\frac{C}{P} \right)^p$$

dove:

- L_{10} durata nominale espressa 10^6 di giri
- C coefficiente di carico dinamico del cuscinetto, espresso in N
- P carico dinamico equivalente sul cuscinetto, espresso in N
- p esponente di durata dell'equazione, con i seguenti valori:
- $P=$ 3 per i cuscinetti a sfere
- $p=$ 10/3 per i cuscinetti a rulli

These types of problems can present themselves due to eventual applications which are not fit or due to mounting errors or for insufficient or lack of lubrication. The above mentioned problems should be considered differently from problems with materials that yield because they can be avoided by the necessary precautions. Where one considers only the wear and tear on the working surface of the bearing, the following conditions should be observed:

- 1. The force and speed of the bearing as explained should correspond to the real conditions of the exercise in order to evaluate the bearing.*
- 2. During the entire exercise period the adequate lubrication should be assured.*
- 3. Experience has shown us that the yielding of many bearings can be attributed to causes other than wear and tear, such as: the choice of an adequate bearing, functional or lubrication defects, the presence of foreign particles in the bearing and other things.*

The life at nominal wear of a single bearing or of a sampling of identical bearings and operating under identical conditions of exercise, consists in the length of the exercise equal to at least a 90% level of reliability. The average life of a group of bearings is well above the nominal life. The life at nominal wear and tear is expressed as L_{10} (millions of rounds - the coefficient of a dynamic load) or L_{10h} (hours of exercise). The equation illustrated below calculates the relation between the nominal life and the coefficient of the dynamic load and the agent load on the bearing:

where:

- L_{10} the nominal life expresses 10^6 rounds
- C the coefficient of the dynamic load of the bearing, expressed in N
- P the dynamic load equivalent on the bearing, expressed in N
- p the exponent of the length of the equation with the following values:
- $P=$ 3 for spherical bearings
- $p=$ 10/3 for roller bearings

Per cuscinetti utilizzati a velocità costante, la durata a fatica nominale, espressa in ore di funzionamento, potrà essere calcolata con la presente equazione:

For bearings used at constant speeds, the life at nominal wear and tear, expressed in functioning hours, can be calculated with the present equation:

$$L_{10h} = \left(\frac{10^6}{n \cdot 60} \right) \left(\frac{C}{P} \right)^p$$

dove:

where:

n velocità di rotazione, espressa in giri/minuti

n the speed of rotation, expressed in rounds per minutes

Nella determinazione delle dimensioni del cuscinetto è necessario basare i calcoli sulla durata a fatica nominale corrispondente all'effettivo impiego. Di solito questo dipende dal tipo di macchina, dalla durata richiesta e dai requisiti inerenti la sicurezza di funzionamento.

In the determination of the dimensions of the bearing it is necessary to base the calculations on the life at nominal wear and tear corresponding to the effective use. Usually this depends on the type of machine, the life requested and on the inherent functioning safety.

Le relazioni tra il regime di rotazione ed il fattore di velocità così come tra la durata nominale ed il fattore di durata sono esplicitati nella sotto riportata tabella.

The relation between the rotation regime and the speed factor as well as the relation between the nominal life and the life factor are explained in the table below.

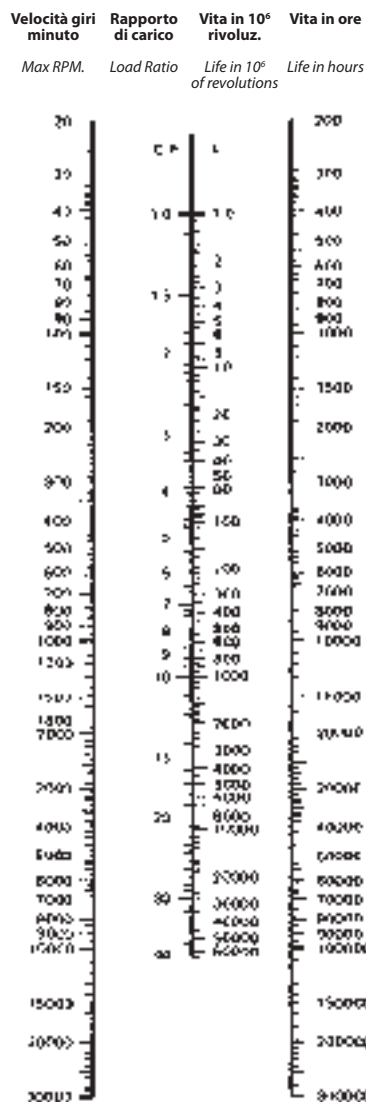

4.1

COEFFICIENTE DI CARICO STATICO C_0

STATIC LOAD RATINGS C_0

Il coefficiente di carico statico C_0 può essere considerato quando il cuscinetto è stazionario o sottoposto a rotazioni e/o oscillazioni particolarmente lente (inferiori a 10 giri max. per minuto), pertanto il coefficiente di carico statico non verrà determinato in funzione della fatica del materiale, ma in base alla deformazione permanente indotta in corrispondenza del punto di contatto tra la superficie volvente e la pista di rotolamento.

Per i cuscinetti radiali, il carico è espresso in direzione radiale, ed il punto di pressione tra i corpi volventi e le piste di rotolamento possono raggiungere i seguenti valori:

4 200 N/mm² per i cuscinetti a sfere

Nelle condizioni sopra indicate, il coefficiente di carico statico C_0 , corrisponde approssimativamente alla deformazione dell'elemento volvente più caricato ed alla deformazione di una delle piste di rotolamento uguale a 1/10 000 del diametro del corpo volvente. Quanto sopra espresso è da considerarsi valido in condizioni normali d'impiego e la deformazione può essere tollerata, senza che l'efficienza di funzionamento sia pregiudicata.

The static load coefficient C_0 can be considered when the bearing is stationary or subject to rotation and or particularly slow oscillation (below 10 rounds max. per minute), therefore the coefficient of the static load will not be determined in function of the wear on the material, but based on the permanent deformation induced at the point of contact between the rotating surface and the rolling track.

As for radial bearings, the load is expressed in radial direction and the pressure point between the rotating bodies and the rolling track can reach the following values:

4 200 N/mm² per spherical bearings

In conditions indicated above, the coefficient of the static load C_0 , corresponds approximately to the deformation of the rotating element plus the load and to the deformation of one of the rolling tracks equal to 1/10 000 of the diameter of the rotating body. All of the above can be considered valid in normal conditions of use and the deformation can be tolerated, without prejudicing the functioning efficiency.

4.2

COEFFICIENTE DI SICUREZZA STATICO S_0

STATIC LOAD SAFETY FACTOR S_0

Per quanto sopra esposto, la capacità di carico statica, determina il valore che un cuscinetto è in grado di sopportare se sottoposto a carichi, ma in assenza o ridotta presenza di movimento. Questi carichi possono comunque creare delle deformazioni, a volte permanenti, per questo motivo è importante considerare il concetto di coefficiente di sicurezza del cuscinetto contro eventuali deformazioni.

Il coefficiente di sicurezza statico, può essere determinato attraverso la seguente formula:

$$S_0 = \frac{C_0}{P_0}$$

considerando che:

- S_0 - fattore di sicurezza statico
- C_0 - coefficiente di carico statico (Kg., N)
- P_0 - carico massimo ammissibile (Kg., N)

For all of the above, the static load capacity, determines the value that a bearing is capable of supporting if subjected to loads, but in absence or in the reduced presence of movement. These loads can anyway create deformations, sometimes permanent, for this reason it is important to consider the concept of the safety factor of the bearing against eventual deformation.

The static safety factor can be determined using the following formula:

consider that:

- S_0 - static safety factor
- C_0 - static load coefficient (Kg.,N)
- P_0 - maximum load allowable (Kg.,N)

Valori indicativi del coefficiente di sicurezza statico S_0
So static safety load rating coefficient

Condizioni operative <i>Working conditions</i>	Cuscinetti a sfere <i>Roller bearings</i>
Elevata precisione di rotazione, con carichi ed urti <i>High rotation precision, with heavy loads and impact</i>	2
Precisione normale di rotazione, con maggiori esigenze di silenziosità <i>Normal rotation precision, with greater need of noiselessness</i>	1
Precisione di rotazione limitata, bassi carichi, minime esigenze di silenziosità <i>Low rotation precision, low loads and minimal need of noiselessness</i>	0,5

4.3

CARICO RADIALE DINAMICO E STATICO EQUIVALENTE EQUIVALENT RADIAL DYNAMIC AND STATIC LOAD

Nelle tabelle dimensionali, vengono indicati i valori dei coefficienti di carico dinamico C_r e statico C_{0r} . Questi valori sono da considerarsi solamente quando il carico è puramente in direzione radiale; però i cuscinetti spesso sono soggetti a più carichi agenti, nonché ad altre situazioni, quali urti, vibrazioni ecc... pertanto occorre convertire il valore del carico dinamico radiale ed assiale in un unico valore chiamato carico radiale dinamico equivalente, per ottenere così i reali carichi applicati sui cuscinetti ed ottenere un valore molto simile alla durata del cuscinetto montato sul supporto. Il carico radiale statico rappresenta la controparte del carico radiale dinamico equivalente di un cuscinetto volvente.

The dynamic C_r and static C_{0r} load coefficient ratings are listed in the dimension tables. These ratings should be considered only when the load is purely in the radial direction; however, the bearings are often subject to several load agents, as well as other situations such as bumps, vibration etc.. therefore, the ratings of the dynamic radial and axial load should be converted to the same rating called the dynamic radial load equivalent. In this way, the rating of the real applied load obtained is very similar to the life of the bearing mounted on the housing. The static radial load represents the counterpart to the dynamic radial load equivalent of a bearing.

5

GIUOCO DEI CUSCINETTI A SFERE CLEARANCE OF BALL BEARINGS

Uno dei principali fattori che può influenzare la durata del cuscinetto è il giuoco. Il giuoco del cuscinetto o giuoco interno (giuoco iniziale) rappresenta il valore di un cuscinetto prima di venir montato su di un albero o all'interno della sede d'alloggiamento. Il giuoco di un cuscinetto può essere inteso sia in senso radiale che assiale, quando lo spostamento dell'anello libero è in senso radiale si parlerà di giuoco radiale, mentre se il movimento è assiale, si parlerà di giuoco assiale del cuscinetto. Il giuoco radiale è determinato come il valore medio di varie misure dello spostamento totale sul piano perpendicolare all'asse del cuscinetto. Tale spostamento è tipico di uno degli anelli del cuscinetto (l'altro è fisso) durante il rotolamento in varie direzioni angolari, sia rispetto all'anello

One of the principal factors that can influence the life of a bearing is the clearance. The clearance of the bearing or the internal clearance (initial clearance) represents the rating of a bearing before mounting it on a shaft or inside of the housing case. The clearance of a bearing can be intended both in a radial sense as well as an axial sense when the movement of the free ring is in the radial sense we say radial clearance while we say axial clearance if the movement is axial. The radial clearance determines the average rating of the various measurements of the total movement on a plain which is perpendicular to the axis of the bearing. Such movement is typical of one of the rings of the bearing (the other is fixed) during the rolling in various angular directions both with respect to the

rotante che a quello fisso e a diverse posizioni angolari della serie di sfere, rispetto agli anelli stessi.

Visti i diversi coefficienti di giuoco richiesti, i cuscinetti radiali possono essere costruiti secondo vari gruppi di giuoco iniziale. Di norma, i cuscinetti a sfere sono costruiti con giuoco radiale normale CN, che, ad impieghi comuni alla maggior parte dei casi, forniscono parametri soddisfacenti di funzionamento. Il giuoco radiale viene evidenziato con l'aggiunta alla sigla del cuscinetto della designazione della classe di precisione (C2, C3, C4, C5), mentre ai cuscinetti costruiti con un giuoco radiale corrispondente al gruppo normale CN non vengono assegnate ulteriori designazioni convenzionali. La durata della vita di un cuscinetto, può essere influenzata da diversi fattori, quali gli accoppiamenti di montaggio, le eventuali differenze di temperature tra l'anello interno e l'anello esterno ecc... da questo si deduce che la scelta del giuoco del cuscinetto è un fattore estremamente importante, perché oltre a determinarne la durata, influisce anche sulla rumorosità, sulle vibrazioni, sulla produzione di calore del cuscinetto. Il giuoco del cuscinetto deve garantirne un buon funzionamento, in particolar modo nel momento in cui potrebbero presentarsi delle contrazioni dell'anello esterno od interno, a seconda dell'applicazione. Le tabelle seguenti forniscono i valori di giuoco radiale.

rotating ring and with respect to the fixed ring and the different angular positions of the series of spheres with respect to the rings themselves.

Considering the different coefficients of clearance required, the radial bearings can be constructed according to various initial groups.

As a norm, spherical bearings are constructed with a normal CN radial clearance that with common use in the majority of cases, supply satisfying functioning parameters. Radial clearance is indicated by an acronym on the bearing with the designation of the precision class (C2, C3, C4, C5), while the bearings constructed with a radial clearance corresponding to the normal group CN are not assigned an ulterior conventional designation.

The life of a bearing can be influenced by different factors accompanied by the mounting and eventual temperature differences between the internal and external ring etc...

From this we deduce that the choice of the clearance of the bearing is an extremely important factor because besides determining the length, it influences the noiselessness, the vibration, the production of heat.

The clearance, of the bearing must guarantee good functioning, in particular, at the moment in which contractions of the external or internal ring may be present depending upon the application. The following table supplies radial clearance ratings.

5.1

TIPOLOGIA GIUOCO RADIALE

TYPES OF RADIAL CLEARANCE

Giuoco Clearance	Significato Meaning	Possibili condizioni operative Possible working conditions
C2	Giuoco radiale dei cuscinetti inferiore a CN <i>Radial clearance of bearings lower than CN</i>	Riduzione rumorosità e vibrazioni <i>Reduction of noisiness and vibrations</i>
CN	Giuoco radiale dei cuscinetti normale <i>Normal radial clearance of bearings</i>	Condizioni normali <i>Normal conditions</i>
C3	Giuoco radiale dei cuscinetti superiore a CN <i>Radial clearance of bearings higher than CN</i>	Montaggio con interferenze su entrambi gli anelli <i>Assembling with interferences on both rings</i>
C4	Giuoco radiale dei cuscinetti superiore a C3 <i>Radial clearance of bearings higher than C3</i>	Errori di montaggio, albero e anello interno riscaldati <i>Assembling mistakes, shaft and inner rings heated</i>
C5	Giuoco radiale dei cuscinetti superiore a C4 <i>Radial clearance of bearings higher than C4</i>	Albero riscaldato e alloggiamento raffreddato <i>Heated shaft and cooled housing</i>

Cuscinetti con foro cilindrico e conico - *Cylindrical and conical bore bearings*

GIUOCO INTERNO RADIALE (ISO 9628:2006) <i>Radial Internal Clearance (ISO 9628:2006)</i>													
Diametro d <i>Diameter d</i>		Diametro d <i>Diameter d</i>	Gruppo N (CN) <i>Group N (CN)</i>		Gruppo 3 (C3) <i>Group 3 (C3)</i>		Diametro d <i>Diameter d</i>		Diametro d <i>Diameter d</i>	Gruppo N (CN) <i>Group N (CN)</i>		Gruppo 3 (C3) <i>Group 3 (C3)</i>	
mm	polici <i>inches</i>		min	max	min	max	mm	polici <i>inches</i>		min	max	min	max
		mm	µm		µm				mm	µm		µm	
12	-	40	10	25	18	33	50,8	2	100	18	43	38	61
12,7	1/2												
14,288	9/16												
15	-												
15,875	5/8												
17	-												
17,462	11/16												
19,05	3/4	40	12	28	20	36	58,738	2 5/16	110	18	43	38	61
20	-												
20,638	13/16	52	12	28	23	41	60,325	2 3/8	120	20	51	46	71
22,225	7/8												
23,812	15/16												
25	-												
25,4	1												
26,988	1 1/16												
28,575	1 1/8	62	13	33	28	46	68,262	2 11/16	125	24	58	53	84
30	-												
30,162	1 3/16												
31,75	1 1/4												
31,75	1 1/4												
33,338	1 5/16												
34,925	1 3/8	72	14	36	30	51	76,2	3	130	24	58	53	84
35	-												
36,512	1 7/16												
38,1	1 1/2												
39,688	1 9/16												
40	-												
41,275	1 5/8	80	14	36	30	51	79,375	3 1/8	140	24	58	53	84
42,862	1 11/16												
44,45	1 3/4												
45	-												
46,038	1 13/16												
47,625	1 7/8												
49,212	1 15/16	85	14	36	30	51	80,962	3 3/16	150	24	58	53	84
50	-												
50,8	2												
50,8	2												
52,388	2 1/16												
53,975	2 1/8												
55	-												
55,562	2 3/16												
57,15	2 1/4												
58,738	2 5/16												
60	-												
60,325	2 3/8												
61,912	2 7/16												
63,5	2 1/2												
65	-												
66,675	2 5/8												
68,262	2 11/16												
69,85	2 3/4												
70	-												
71,438	2 13/16												
73,025	2 7/8												
74,612	2 15/16												
75	-												
76,2	3												
79,375	3 1/8												
80	-												
80,962	3 3/16												
82,55	3 1/4												
85	-												
85,725	3 3/8												
87,312	3 7/16												
88,9	3 1/2												
88,9	3 1/2												
90	-												
93,662	3 11/16												
95	-												
100	-												
100,012	3 15/16												
101,6	4												

GIUOCO INTERNO RADIALE (ISO 5753-1:2009)
Radial Internal Clearance (ISO 5753-1:2009)

Diametro d <i>Diameter d</i> mm		Gr µm	
		C5	
>	≤	min.	max.
12	18	25	45
18	24	28	48
24	30	30	53
30	40	40	64
40	50	45	73
50	65	55	90
65	80	65	105
80	100	75	120
100	120	90	140
120	140	105	160

Il processo di lubrificazione, ha il compito principale di evitare che vi possa essere eccessivo attrito tra le sfere, le piste di rotolamento e le gabbie, ridurre entro certi limiti la rumorosità di funzionamento, assicurare ai cuscinetti protezione dalla corrosione, oltre a diminuire anche l'eventuale attrito delle tenute. I supporti **ISB**[®] sono lubrificati con grassi che mantengono le proprie caratteristiche nel tempo, in condizioni normali d'esercizio. Qualora le condizioni d'esercizio lo richiedessero (condizioni esterne sfavorevoli, innalzamento della temperatura, aumento dei giri del cuscinetto), bisognerebbe procedere con ulteriori lubrificazioni, per consentire al cuscinetto di operare sempre nelle condizioni più favorevoli. Le tabelle riportate a seguito indicano quelli che sono i valori orientativi per i periodi di lubrificazione dei supporti ri-lubrificabili. Occorre precisare che esistono anche dei supporti esenti da manutenzione, di seguito esplicitati.

*The lubrication process is meant principally to avoid excessive wear between the sphere, the rolling track and the cage to reduce to certain limits the noise level of functioning, assure the protection of the bearing against corrosion and furthermore to diminish eventual wear from the seal. **ISB**[®] housings are lubricated with grease that maintains its characteristics over time during normal exercise conditions.*

When conditions require (external unfavourable conditions, increased temperature, increased rounds of the bearing), an ulterior greasing should be done in order to permit the bearing to always operate in more favourable conditions. The following table indicates what the guideline ratings are for the periods of lubrication of housings which can be lubricated again. We should note that some housings exist which do not require maintenance and this is explained as follows.

6.1
SUPPORTI ESENTI DA MANUTENZIONE
MAINTENANCE-FREE BEARING UNITS

I supporti **ISB**[®] esenti da manutenzione, sono unità pronte al montaggio. I cuscinetti utilizzati in questo tipo di supporto contengono una tipologia di grasso d'elevata qualità, a base di litio saponificato, che ne consente un funzionamento continuo a temperature che possono variare dai -30°C a +110°C. Il sistema di tenuta garantisce ai cuscinetti di essere perfettamente protetti da eventuali agenti esterni inquinanti (polvere, umidità, fluidi vari) e di prevenire la fuoriuscita del grasso. La rotazione stessa dell'albero consente la circolazione del grasso e la lubrificazione stessa all'interno del cuscinetto si mantiene per un lungo periodo. I principali vantaggi nell'utilizzo di supporti esenti da manutenzione sono raggruppabili con quanto sotto riportato:

***ISB**[®] housings which are exempt from maintenance are units which are ready to be mounted. The bearings used in this type of housing contain a high quality type of grease made of saponified lithium which allows the functioning to continue at temperatures which vary from -30°C to +110°C. The sealing system guarantees that the bearings are perfectly protected from eventual external pollutants (dust, humidity, various fluids) and it prevents the grease from exiting. The rotation of the shaft itself permits the grease to circulate and the lubrication itself inside the bearing maintains itself for a long period. The main advantages of using these housings is that they are exempt for maintenance and are regrouped as reported below:*

- maggior resistenza ad eventuali infiltrazioni d'agenti inquinanti esterni
- mancanza di dispersioni del grasso utilizzato per la lubrificazione
- unità compatta, perché non vi sono dispositivi di lubrificazione
- risparmio in termini di tempo e costi di manutenzione
- *increased resistance to eventual infiltration from pollutants*
- *no dispersion of grease used to lubricate*
- *compact units because there are no lubrication devices*
- *savings in terms of time and the expense of maintenance*

6.2

SUPPORTI RI-LUBRIFICABILI

RE-GREASEABLE BEARING UNITS

I supporti **ISB®** nelle versioni in ghisa ed in acciaio inox possono essere forniti con apposito ingrassatore che consente periodicamente d'effettuare la ri-lubrificazione del cuscinetto. Il foro dove è posizionato l'ingrassatore può creare un indebolimento della struttura del supporto, anche se da studi effettuati, la posizione del foro è posta in modo tale da rendere minimo l'effetto sopra citato. In condizioni normali è preferibile l'utilizzo di supporti esenti da manutenzione, anche se vi sono comunque applicazioni dove risulta indispensabile l'utilizzo di supporti ri-lubrificabili, come nei casi citati di seguito:

- utilizzo in condizioni estremamente critiche, ove non sia possibile l'utilizzo di ulteriori dispositivi di chiusura (coperchi di protezione)
- utilizzo su macchinari che lavorano ad intermittenza e dove sono presenti agenti inquinanti esterni
- utilizzo in casi dove la rotazione risulta elevata e si possono avere problemi di rumorosità
- utilizzo del supporto con temperature superiori ai +140°C

In condizioni normali d'utilizzo dei supporti **ISB®** la quantità di grasso presente nel cuscinetto è sufficiente per tutta la durata della vita del supporto. Con il verificarsi di condizioni esterne sfavorevoli, come elevate variazioni termiche, numero di giri più elevati, sarà indispensabile valutare adeguatamente questi fattori perché possono notevolmente influire sugli intervalli di lubrificazione.

*The **ISB®** housing units in the cast iron version and in the stainless steel version can be supplied with the necessary lubricator which permits periodic re-greasing of the bearings. The bore where the greaser is positioned can create a weakness in the structure of the housing, even if studies performed, the position of the bore is located in such a way as to render the effects of the above mentioned minimal. In normal conditions it is preferable to use housings which are exempt from maintenance. Even so, there are, in any case, some applications where the use of re-grease bearings is indispensable, as in the case cited below:*

- *use in extremely critical conditions, where it is not possible to use ulterior closure devices (protective covers)*
- *use on machines that work at intermittence and where external pollutant agents are present.*
- *use in cases where the number of rotations are elevated and the may be noise problems.*
- *use when temperatures are above +140° C.*

***ISB®** housing units used in normal conditions, contain a quality grease inside the bearing which is sufficient for all of the life of the bearing. As unfavourable external conditions such as elevated thermal variations, the number of rounds increased, are verified it will be indispensable to evaluate adequately these factors because the can notably influence the lubrication intervals.*

6.3

PERIODICITÀ DELLA LUBRIFICAZIONE

PERIODICITY OF LUBRICATION

I valori, riportati nella sotto indicata tabella, sono relativi agli intervalli di lubrificazione, per un funzionamento approssimativo di 8 ore giornaliere.

The ratings, indicated in the table below, are relative to the intervals of lubrication for functioning approximately 8 hours per day.

Temperatura Temperature	Condizioni d'impiego - Working conditions			Cuscinetto Bearing	Grasso Grease
	Ordinarie Normal	Polvere Dust	Polvere ed umidità Dust and damp		
50°C ➤ 50°C 70°C ➤ 70°C 70°C ➤ 100°C	360/720 giorni/days 360 giorni/days 180 giorni/days	360 giorni/days 120 giorni/days 60 giorni/days	120 giorni/days 30 giorni/days 15 giorni/days	Normale Normal	Litio Lithium
100°C ➤ 120°C 120°C ➤ 150°C	60 giorni/days 15 giorni/days	15 giorni/days 5 giorni/days	5 giorni/days 2 giorni/days	Termoresistente Heat-resistant	Calcio Calcium
150°C ➤ 180°C 180°C ➤ 200°C	7 giorni/days 3 giorni/days	2 giorni/days 1 giorno/day	1 giorno/day 1 giorno/day	Termoresistente Heat-resistant	Speciale Special

I supporti possono essere ri-lubrificati attraverso l'apposito ingrassatore (tipo a sfera), che si trova sulla parte esterna del supporto. Il grasso viene inserito gradualmente nell'ingrassatore (1) ed attraverso un canaletto (2) che si trova nella parte interna del supporto raggiunge due fori (3) che permettono l'ingresso del grasso nel cuscinetto. Si prega di prestare sempre molta attenzione a quanto segue:

- evitare l'ingrassaggio al primo montaggio
- non utilizzare mai olio per la lubrificazione
- utilizzare sempre il grasso raccomandato
- pulire bene l'ingrassatore da eventuali impurità
- inserire il grasso in maniera graduale e lenta, facendo possibilmente ruotare l'albero
- non introdurre mai quantità eccessive di grasso (potrebbe comprometterne il funzionamento)
- se il cuscinetto è stato smontato, prestare particolare attenzione a quando viene rimontato, in modo tale che la parte prolungata dell'anello interno sporgente (4) sia dallo stesso lato dell'ingrassatore, perché solo in questa posizione è possibile la ri-lubrificazione del supporto.

The housings can be re-lubricated using the greaser supplied for that purpose (sphere type), which can be found on the external part of the housing. The grease is inserted gradually in the greaser (1) and using the small canal (2) which can be found in the internal part of the housing, reach two holes (3) which permit the entry of the grease into the bearing. We recommend that careful attention be given to the following:

- *avoid using grease when first mounting*
- *do not ever use oil to lubricate*
- *always use the grease recommended*
- *clean the greasing tool well from eventual impurities*
- *insert the grease in a gradual and slow manner making the shaft rotate if possible*
- *never introduce excessive quantities of grease (they could compromise the functioning)*
- *if the bearing has been dismantled, give careful attention to remounting so that the prolonged part of the internal ring which sticks out (4) is from the same side as the greaser because this is the only position in which it is possible to re-lubricate the housing*

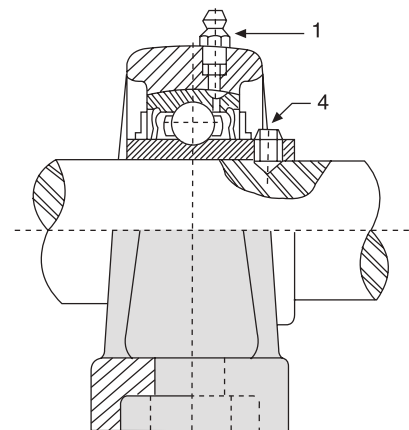
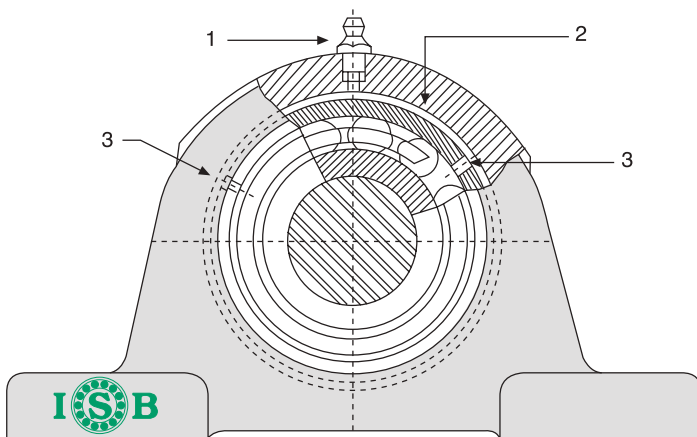

6.5

QUANTITÀ DI GRASSO

GREASE QUANTITY

Normalmente i cuscinetti per supporti **ISB®** sono riempiti circa al 30-35%, percentuale adatta per la maggior parte delle applicazioni più comuni. Se i cuscinetti fossero riempiti con una quantità maggiore, questo provocherebbe una fuoriuscita del grasso, ed anche in virtù della resistenza che si verrebbe a creare, ci sarebbe un effetto di surriscaldamento. Nelle lubrificazioni periodiche si consiglia di attenersi quanto più alla quantità di grasso indicata nella sotto riportata tabella. Per impieghi a basse velocità i valori riportati in tabella possono anche aumentare, non oltre il doppio di quanto indicato.

*Normally the bearings for the **ISB®** housings are filled to 30-35%, the suitable percentage for most common applications.*

If the bearings were to be filled with a larger quantity, this would provoke the grease to overflow and also with resistance that would be created there would be an overheating effect.

When lubricating periodically, it is advisable to use the quantities of grease indicated in the table below.

For low speed uses, the values in the table can even increase but not more than double the amount indicated.

Tipologia di cuscinetto Bearing type			Quantità (g) Quantity (g)
UC 201	-	-	1,6
UC 202	-	-	1,6
UC 203	-	-	1,6
UC 204	-	-	1,6
UC 205	-	UK 205	1,6
UC 206	UCX 05	UK 206	3,1
UC 207	UCX 06	UK 207	4
UC 208	UCX 07	UK 208	5
UC 209	UCX 08	UK 209	5,7
UC 210	UCX 09	UK 210	6,7
UC 211	UCX 10	UK 211	8,6
UC 212	UCX 11	UK 212	11,7
UC 213	UCX 12	UK 213	13,5
UC 214	UCX 13	UK 214	16,2
UC 215	UCX 14	UK 215	18
UC 216	UCX 15	UK 216	22,5
UC 217	UCX 16	UK 217	27,5
UC 218	UCX 17	UK 218	35
-	UCX 18	-	47
-	UCX 20	-	67
-	-	-	-

Tipologia di cuscinetto Bearing type		Quantità (g) Quantity (g)
UC 305	UK 305	4
UC 306	UK 306	5,4
UC 307	UK 307	7,3
UC 308	UK 308	9,5
UC 309	UK 309	11,9
UC 310	UK 310	16,1
UC 311	UK 311	21
UC 312	UK 312	26,5
UC 313	UK 313	31,5
UC 314	UK 314	40
UC 315	UK 315	47,5
UC 316	UK 316	55,5
UC 317	UK 317	65
UC 318	UK 318	76
UC 319	UK 319	91,5
UC 320	UK 320	116,5
UC 321	UK 321	135
UC 322	UK 322	164
UC 324	UK 324	196
UC 326	UK 326	242
UC 328	UK 328	288,5

In linea di massima, quasi tutti i supporti **ISB®** sono forniti con apposito ingrassatore in ottone, tipo standard (su richiesta anche zincato o in acciaio inox). Per poter effettuare l'ingrassaggio, sarà necessario utilizzare l'apposito attrezzo. Qualora vi fossero delle necessità particolari d'applicazione è possibile fornire anche altri tipi di ingrassatori, come riportato nei seguenti disegni.

Most **ISB®** housings are furnished with the right grease nipple in brass as a standard type (upon request also zinc or stainless steel plated) In order to carry out greasing, it will be necessary to use the proper tool. Should there be necessity for a particular application it is possible to supply other types of grease nipple as can be seen in the following diagrams.



Ottone - Zincati - Acciaio inox
Brass - Galvanized - Stainless steel

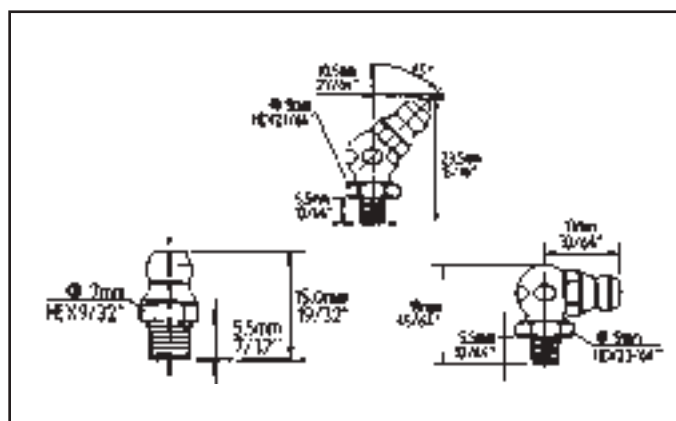

Tipo standard - *Standard type*

Disponibile solo su richiesta - *Available on request*

6.7

TABELLA DEI LUBRIFICANTI

TABLES OF LUBRICANTS

I lubrificanti per cuscinetti utilizzati nei supporti ISB®, dovranno rispondere ai seguenti requisiti:

- essere stabili, sia a livello fisico che chimico
- essere privi di corpi estranei provenienti da componenti meccanici (quali abrasivi, sostanze metalliche ecc...)
- garantire un coefficiente minimo d'attrito
- avere una buona capacità lubrificante

La seguente tabella, esplica quelli che sono i lubrificanti comunemente utilizzati nonché le loro principali caratteristiche.

The lubricants for bearings used in ISB® housings should respond to the following requirements:

- be stable, both on a physical as well as a chemical level
- be exempt foreign bodies originating from mechanical components (abrasives, metallic substances etc...)
- guarantee a minimum coefficient of rubbing
- have a good lubricating capacity

The following table explains which are the common lubricants used as well as their principle characteristics.

Marca e tipo Brand name	Grasso base Basic type grease	Temperatura d'esercizio Operating temperature	Caratteristiche Characteristics
Exxon Beacon 325	Grasso sintetico Synthetic grease	-55 ➤ +120°C	Grasso generico General grease
Chevron SRI-2	Grasso minerale Mineral grease	-35 ➤ +180°C	Indicato alle alte temperature con buona resistenza all'acqua High temperature range with good water resistance
Shell Alvania 2	Grasso minerale Mineral grease	-35 ➤ +120°C	Lunga durata Long life
DuPont Krytox 240AC (Mil-G-27617)	Grasso fluorato Fluorinate grease	-35 ➤ +290°C	Indicato per altissime temperature. Non perde le proprietà lubrificanti (costo elevato) High temperature stability with good lubricating properties and (very high price)
Shell Dolium R	Grasso di petrolio Petroleum grease	-40 ➤ +150°C	Resistente alla corrosione ed all'acqua Good corrosion resistance and water washout properties
KYODO SRL	Grasso sintetico Synthetic grease	-40 ➤ +150°C	Bassa rumorosità e bassi carichi Low noise and low torque applications
Mobil HP	Litio Lithium complex	-30 ➤ +110°C	Resistente alla corrosione ed alle vibrazioni, velocità moderate Vibration, moderate speeds and good corrosion resistance

I supporti **ISB**® normalmente vengono forniti già montati e solitamente confezionati singolarmente. Occorre prestare attenzione nel momento dell'apertura della confezione, che non vadano persi eventuali accessori aggiunti, come ad esempio chiavi ed ingrassatori. I supporti **ISB**® sono agevolmente montabili fin dall'inizio, occorre comunque prestare attenzione a quanto sotto riportato, per consentire al supporto di avere una normale vita d'esercizio:

- assicurarsi che la superficie dove viene montato il supporto sia sufficientemente rigida e piana
- evitare disallineamenti oltre i $\pm 2^\circ$ tra la superficie dove viene montato il supporto e l'asse dell'albero

ISB® bearing units are normally furnished already mounted and singularly packaged. Care should be taken while opening the package so that eventual added accessories such as keys and grease nipple are not lost.

ISB® bearing units are easily to mount without prior know how, it is however important to give attention to the following points in order to have a normal live span of the unit:

- ascertain that the surface where the unit will be mounted is sufficiently rigid and flat.
- avoid misalignments outside of $\pm 2^\circ$ between the surface where the unit is to be mounted and the axis of the shaft.

7.1
FISSAGGIO CON GRANI
SETSCREWS FIXING

Il fissaggio del cuscinetto all'albero avviene attraverso l'avvitamento di due grani che si trovano sulla superficie del cuscinetto stesso (fig. A). Per razionalizzare tale operazione è consigliabile effettuare quanto segue: appiattire leggermente l'albero nella zona del grano di fissaggio (fig. 1) oppure ricavare un leggero incavo (fig. 2). Nel caso si proceda con l'incavo occorre prestare molta attenzione affinché non vi siano spostamenti assiali che possano deformare il cuscinetto. I grani di fissaggio dovrebbero essere serrati il più possibile, in modo da evitare qualsiasi spostamento dell'anello interno sull'albero. **Si raccomanda di non stringere eccessivamente i grani**, che potrebbero causare una deformazione dell'anello interno, con conseguente deformazione dello stesso e causare uno scorrimento non uniforme. I grani di fissaggio andranno montati seguendo i valori indicati nelle sotto riportate tabelle. Se il cuscinetto dovesse essere soggetto a forti oscillazioni o carichi assiali, è consigliabile ricavare sull'albero uno spallamento (fig. 3) in modo tale da bloccare l'anello interno con un dado contro lo spallamento stesso.

The fixing of the bearing to the shaft takes place using setscrews the are located on the surface of the bearing itself (fig. A). To realize such an operation it is advisable to do the following:

flatten slightly the shaft in the zone where the setscrew will be fixed (fig. 1) or hollow out a small cavity (fig. 2). In the case of the cavity, be very careful that there are no axial movements that could deform the bearing.

The setscrews should be tightened as much as possible in such a way as to avoid movement of the ring inside the shaft.

We recommend however not to over tighten or tighten excessively the setscrews however as they could cause a deformation of the internal ring with consequent deformation of the bearing and cause non uniform running.

The setscrews will be mounted according to the values indicated on the table below. If the bearing should be subject to strong oscillations or axel loads, it is advisable to hollow out a support to the shaft in such a way as to block the internal ring with a nut against the support itself.

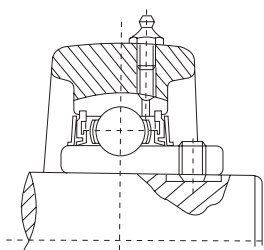

Fig. 1

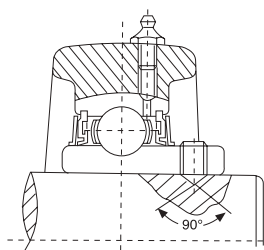

Fig. 2

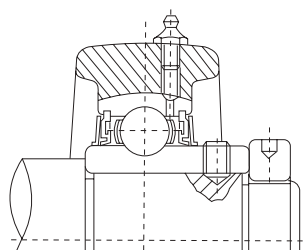

Fig. 3



Fig. A

Coppie di serraggio raccomandate (serie metriche)

Recommended locking torque (metric series)

Tipologia di cuscinetti Bearings type			Sigla grani Designation setscrews	Coppia di serraggio Locking torque Nm (max)
UC 201 UC 206	-	-	M 6x1	3,9
-	-	UC 305 UC 306	M 6x1	4,9
-	UCX 05	-	M 6x1	5,8
UC 207 UC 209	-	-	M 8x1	7,8
-	UCX 06 UCX 08	UC 307	M 8x1	9,8
-	UCX 09	-	M 10x1	16,6
UC 210 UC 213	-	UC 308 UC 309	M 10x1	19,6
-	UCX 10	-	M 10x1	22,5
-	UCX 11 UCX 12	-	M 10x1	24,5
UC 214 UC 218	UCX 13 UCX 16	UC 310 UC 314	M 12x1,5	28
-	UCX 17	-	M 12x1,5	34,3
-	UCX 18	UC 315 UC 316	M 14x1,5	34,3
-	UCX 20	UC 317 UC 319	M 16x1,5	53,9
-	-	UC 320 UC 324	M 18x1,5	58,8
-	-	UC 326 UC 328	M 20x1,5	78,4

Coppie di serraggio raccomandate (serie in pollici)

Recommended locking torque (inches series)

Tipologia di cuscinetti Bearings type			Sigla grani Designation setscrews	Coppia di serraggio Locking torque lbf-inch (max)
UC 201 UC 206	-	-	¼ - 28 UNF	34
-	-	UC 305 UC 306	¼ - 28 UNF	43
-	UCX 05	-	¼ - 28 UNF	52
UC 207 UC 209	-	-	5/16 - 24 UNF	69
-	UCX 06 UCX 08	UC 307	5/16 - 24 UNF	86
-	UCX 09	-	3/8 - 24 UNF	147
UC 210 UC 213	-	UC 308 UC 309	3/8 - 24 UNF	173
-	UCX 10	-	3/8 - 24 UNF	199
-	UCX 11 UCX 12	-	3/8 - 24 UNF	216
UC 214 UC 218	UCX 13 UCX 16	UC 310 UC 314	7/16 - 20 UNF	260
-	UCX 17	-	½ - 20 UNF	303
-	UCX 18	UC 315 UC 316	9/16 - 18 UNF	303
-	UCX 20	UC 317 UC 319	5/8 - 18 UNF	477
-	-	UC 320	5/8 - 18 UNF	520
-	-	-	-	-

Coppie di serraggio raccomandate (serie metriche)
Recommended locking torque (metric series)

Tipologia di cuscinetti <i>Bearings type</i>	Sigla grani <i>Designation setscrews</i>	Coppia di serraggio <i>Locking torque Nm (max)</i>
SB - RB 201 SB - RB 203	M 5x08	3,4
SB - RB 204 SB - RB 206	M 6x1	4,4
SB - RB 207 SB - RB 209	M 8x1	6,8

Coppie di serraggio raccomandate (serie in pollici)
Recommended locking torque (inches series)

Tipologia di cuscinetti <i>Bearings type</i>	Sigla grani <i>Designation setscrews</i>	Coppia di serraggio <i>Locking torque lbf-inch (max)</i>
SB - RB 201 SB - RB 203	10 - 32 UNF	34
SB - RB 204 SB - RB 206	¼ - 28 UNF	43
SB - RB 207 SB - RB 209	5/16 - 24 UNF	69

7.2

FISSAGGIO CON BUSSOLA DI TRAZIONE

TAPER ADAPTER FIXING

Quando si vuole procedere al montaggio della bussola di trazione, occorre posizionare il supporto su di una superficie, perfettamente piana (è consigliabile lasciare i bulloni di fissaggio leggermente allentati, per poi stringerli ad operazione avvenuta). Introdurre la bussola in modo tale che la parte conica si trovi quasi al centro del cuscinetto e battere leggermente con un attrezzo, l'intera superficie laterale della bussola. Procedere con l'inserimento della rondella e stringere a fondo la ghiera con apposita chiave. **Si raccomanda di non stringere troppo la ghiera**, perché potrebbero causarsi delle deformazioni, pertanto attenersi ai valori sotto indicati. Al termine delle operazioni sopra elencate, provare la rotazione manuale dell'albero e verificare che ruoti agevolmente.

Once ready to proceed with the mounting of the taper adapter, it is necessary to position the support on a perfectly flat surface (it's a good idea to leave the fixing bolts slightly loose and then tighten them once the operation is complete). Introduce the taper adapter with the conical part nearly at the centre of the bearing and with a tool, hit the entire lateral surface of the bolt lightly. Proceed to insert the washer and tighten completely the ferrule/ring with the proper key.

Attention: over tightening the ferrule could cause deformations therefore, stay within the values indicated below. *At the end of the operation mentioned above, try to manually rotate the shaft and verify that it rotates with ease.*

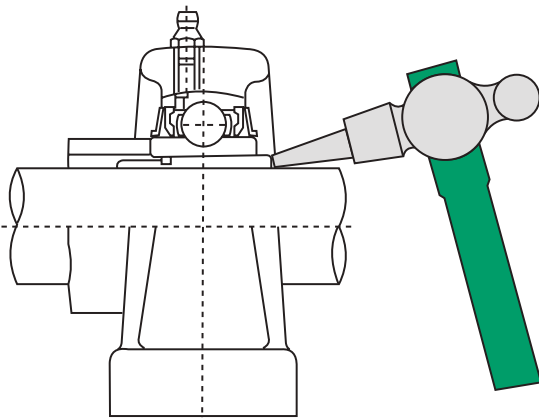

Coppie di serraggio raccomandate (serie metriche)

Recommended locking torque (metric series)

Tipologia di cuscinetti <i>Bearings type</i>	Bussola di trazione <i>Taper adapter</i>	Coppia di serraggio - Locking torque	
		Kg - cm	Nm (max)
UK 205	H 205	254	25
UK 206	H 206	305	30
UK 207	H 207	407	40
UK 208	H 208	509	50
UK 209	H 209	612	60
UK 210	H 210	764	75
UK 211	H 211	1019	100
UK 212	H 212	1325	130
UK 213	H 213	1529	150
UK 215	H 215	1732	170
UK 216	H 216	2038	200
UK 217	H 217	2344	230
UK 218	H 218	2752	270

7.3

FISSAGGIO CON ANELLO ECCENTRICO DI SERRAGGIO

ECCENTRIC COLLAR LOCKING FIXING

Un altro sistema utilizzabile per il fissaggio tra il cuscinetto e l'albero, può avvenire attraverso l'utilizzo di un anello eccentrico di serraggio. In questo caso l'albero e l'anello interno verranno collegati proprio serrando l'anello eccentrico nel senso di rotazione dell'albero. Nel montaggio del supporto con anello eccentrico di serraggio, assicurarsi di compiere correttamente le seguenti operazioni; accertarsi che la superficie dove verrà installato il supporto sia idonea per quell'applicazione; verificare che l'estremità dell'albero sia priva di bave e che la vite di bloccaggio dell'anello eccentrico non fuoriesca dalla parte dell'albero; assicurarsi che il supporto sia ben bloccato alla superficie e che non vi siano possibilità di carichi assiali eccessivi; inserire l'anello eccentrico facendolo girare nel senso di rotazione e con apposito strumento battere in modo da fissare l'anello eccentrico; al termine di queste operazioni serrare la vite di bloccaggio presente sul collare attenendosi ai valori riportati nelle sotto indicate tabelle. Questo sistema di fissaggio non è particolarmente indicato per applicazioni nelle quali gli alberi possono variare il senso di rotazione.

Another system that can be used to fix the bearing and the shaft is to use the eccentric collar locking system.

In this case the shaft and the internal ring actually linked by tightening the eccentric ring in the rotation direction of the shaft. When mounting the eccentric collar locking system support, be sure to correctly perform the task; ascertain that the surface where it will be installed is fit for this application; verify that the edge of the shaft has no metal burr and that the blocking screws of the eccentric ring does not protrude out of the shaft; make sure that the support is securely fastened to the surface and that there is no possibility for excessive axial loads.

Insert the eccentric ring by turning, in the rotation direction, and with the proper tool, strike it so as to fix the eccentric ring.

At the end of this operation, tighten the blocking screw present on the collar staying within the limits indicated on the table below. This fixing system is not particularly indicated for applications in which the shafts can rotate in different directions.

Coppie di serraggio raccomandate (serie metriche)

Recommended locking torque (metric series)

Tipologia di cuscinetti Bearings type			Sigla grani Designation setscrews	Coppia di serraggio Locking torque Nm (max)
HC 204 HC 205	-	SA 201 SA 205	M 6x1	7,8
HC 206 HC 210	HC 303 HC 307	SA 206 SA 211	M 8x1	9,8
HC 211 HC 215	HC 308 HC 312	SA 212	M 10x1	29,4
-	HC 313 HC 314	-	M12x1,5	34,3
-	HC 315 HC 317	-	M 16x1,5	53,9
-	HC 318 HC 320	-	M 20x1,5	78,4

Coppie di serraggio raccomandate (serie in pollici)

Recommended locking torque (inches series)

Tipologia di cuscinetti Bearings type			Sigla grani Designation setscrews	Coppia di serraggio Locking torque lbf-inch (max)
HC 204 HC 205	-	SA 201 SA 205	¼ - 28 UNF	69
HC 206 HC 210	HC 303 HC 307	SA 206	5/16 - 24 UNF	86
HC 211 HC 215	HC 308 HC 312	SA 212	3/8 - 24 UNF	260
-	HC 313 HC 314	-	½ - 20 UNF	350
-	HC 315 HC 317	-	5/8 - 18 UNF	520
-	HC 318 HC 320	-	¾ - 16 UNF	700

7.4

MOVIMENTO ASSIALE DOVUTO ALL'ESPANSIONE O AL RESTRINGIMENTO AXIAL MOVEMENT DUE TO EXPANSION AND SHRINKAGE

Succede spesso che in presenza di alcune particolari condizioni di lavoro, l'albero si possa espandere o restringere, e che quindi il cuscinetto si possa muovere.

L'albero della ruota del camion per esempio (mozzo), deve essere mosso in direzione assiale al limite: quando l'albero viene utilizzato a temperature elevate, l'espansione termica fa sì che lo stesso diventi più largo e lungo.

Se i cuscinetti sono tutti fissati sull'albero si verifica sul cuscinetto un carico assiale straordinario, e anche a causa dell'espansione termica potrebbe verificarsi una rottura del cuscinetto stesso.

Per questa ragione, in presenza di espansioni o restringimenti dell'albero bisogna utilizzare un supporto fisso da un lato e uno mobile dall'altro.

It often happens that in the presence of some particular working conditions, the shaft may expand or shrink and therefore the bearings may move.

The shaft of the wheels of a truck for example, should be moved in the axial direction to the limit: when the shaft is used at high temperatures, thermal expansion takes place and the shaft becomes wider and longer.

If the bearings are all attached to the shaft the bearing will be have an extraordinary axial load and could even break due to the thermal expansion.

This is why, in the presence of an expanding or shrinking shaft, fixed support on one side or a mobile one from the other should be used.

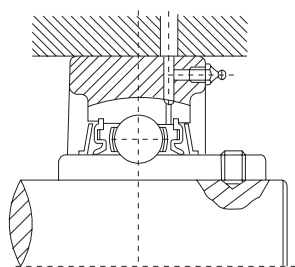

Fig. 1

Fig.1) Come mostrato, è consigliabile utilizzare il tipo di supporto a cartuccia con cuscinetto avente diametro esterno cilindrico, nella stessa maniera che con i soliti cuscinetti. Quando si utilizzano supporti a cartuccia, bisogna prestare attenzione a non causare una deformazione nel momento dell'inserimento. Tutto il corpo della struttura come sopra mostrato, è preparato per essere utilizzato con alte temperature.

Fig.2) Ad ogni modo la chiave è lavorata sull'albero, e generalmente al posto dei grani di fissaggio viene utilizzata una vite a testa esagonale. Il movimento assiale causato dall'espansione o dal restringimento dell'albero è regolato da questo.

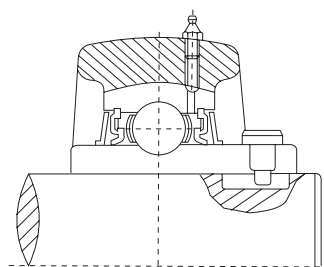

Fig. 2

Fig.1) As shown it is desirable to use a cartridge type bearing with a cylindrical outer diameter in the same manner as with ordinary bearings. When using cartridge type housings, be careful not to cause a deformation at the time of insertion. The complete housing with the above shown structure is prepared for use at high temperatures.

Fig.2) The key is machined on the shaft and a dog point hexagon hollow setscrew is generally used in place of the setscrew. Axial movement due to shaft expansion and shrinkage is in this way regulated.

7.5

SMONTAGGIO DEL SUPPORTO

DISASSEMBLY OF BEARING UNIT

Se per una qualsiasi ragione, si rende necessaria la sostituzione del supporto, occorre ripercorrere le stesse operazioni che si erano effettuate per il montaggio, ma al contrario. È importante prestare attenzione particolare ai seguenti aspetti:

- nel caso il supporto sia stato fissato con i grani di bloccaggio, è importante svitare completamente gli stessi, in modo tale da evitare che nel momento dello smontaggio, i grani non possano in alcun modo strisciare sull'albero segnandolo
- nel caso il supporto sia stato utilizzato con bussola di trazione, occorre sollevare la linguetta della rondella e svitare leggermente la ghiera, dopodiché appoggiando un anello, battere con apposito attrezzo su tutta la superficie della ghiera, fin tanto che non si può estrarre la bussola. Fare molta attenzione a non danneggiare le filettature.

If for any reason, it becomes necessary to substitute the housing, the same operation as was done while mounting must be carried out, but in reverse. Give careful attention to the following aspects:

- If the housing had been fixed with setscrews, it is important to unscrew them completely to keep them from sliding against the shaft while dismounting.
- If the taper adapter has been used to fix the housing, lift the lip of the washer and unscrew slightly the lock nut then while supporting the ring, strike with the proper tool on the surface of the lock nut until the taper adapter can be extracted. Be very careful not to damage the threading.

7.6

SOSTITUZIONE DEL CUSCINETTO

BEARING REPLACEMENT

Se per una qualsiasi ragione, si rendesse necessario sostituire il cuscinetto presente all'interno del supporto, questo non significa che debba essere sostituito anche il corpo del supporto. Per effettuare tale operazione occorre che le viti di bloccaggio siano ben fissate, per non interferire nelle operazioni di sostituzione. Utilizzando un tubo o un attrezzo simile, ed inserendolo all'interno del foro del cuscinetto, quest'ultimo dovrà essere fatto ruotare di circa 90° facendo in modo di estrarlo dalle guide ricavate all'interno della fusione del supporto; dopodiché si procederà nell'operazione inversa per inserire il nuovo cuscinetto.

If for any reason it becomes necessary to substitute the internal bearing of the housing, this does not mean that the housing must also be substituted. To do such an operation the blockage screws are well fixed so as not to interfere with the substitution operation. Using a tube or a similar tool and inserting it inside the bore in the bearing and rotating the bearing about 90° in such a way as to extract it from the guide hollowed out inside the casting of the housing; after which proceed inversely to insert the new bearing.

Durezza ROCKWELL <i>Hardness</i>	Durezza VICKERS <i>Hardness</i>	Durezza BRINNEL <i>Hardness</i>		Durezza ROCKWELL <i>Hardness</i>		Durezza SHORE <i>Hardness</i>
		Scala C <i>Scale C</i>	Sfera Standard <i>Ball</i>	Sfera ¹⁾ <i>Ball¹⁾</i>	Scala A <i>Scale A</i>	
68	940	-	-	85,6	-	97
67	900	-	-	85,0	-	95
66	865	-	-	84,5	-	92
65	832	-	739	83,9	-	91
64	800	-	722	83,4	-	88
63	772	-	705	82,8	-	87
62	746	-	688	82,3	-	85
61	720	-	670	81,8	-	83
60	697	-	654	81,2	-	81
59	674	-	634	80,7	-	80
58	653	-	615	80,1	-	78
57	633	-	595	79,6	-	76
56	613	-	577	79,0	-	75
55	595	-	560	78,5	-	74
54	577	-	543	78,0	-	72
53	560	-	525	77,4	-	71
52	544	500	512	76,8	-	69
51	528	487	496	76,3	-	68
50	513	475	481	75,9	-	67
49	498	464	469	75,2	-	66
48	484	451	455	74,7	-	64
47	471	442	443	74,1	-	63
46	458	432	432	73,6	-	62
45	446	421	421	73,1	-	60
44	434	409	409	72,5	-	58
43	423	400	400	72,0	-	57
42	412	390	390	71,5	-	56
41	402	381	381	70,9	-	55
40	392	371	371	70,4	-	54
39	382	362	362	69,9	-	52
38	372	353	353	69,4	-	51
37	363	344	344	68,9	-	50
36	354	336	336	68,4	(109,0)	49
35	345	327	327	67,9	(108,5)	48
34	336	319	319	67,4	(108,00)	47
33	327	311	311	66,8	(107,5)	46
32	318	301	301	66,3	(107,0)	44
31	310	294	294	65,8	(106,0)	43
30	302	286	286	65,3	(105,5)	42
29	294	279	279	64,7	(104,5)	41
28	286	271	271	64,3	(104,0)	41
27	279	264	264	63,8	(103,0)	40
26	272	258	258	63,8	(102,5)	38
25	266	253	253	62,8	(101,5)	38
24	260	247	247	62,4	(101,0)	37
23	254	243	243	62,0	100,0	36
22	248	237	237	61,5	99,0	35
21	243	231	231	61,0	98,5	35
20	238	226	226	60,5	97,8	34
(18)	230	219	219	-	96,7	33
(16)	222	212	212	-	95,5	32
(14)	213	203	203	-	93,9	31
(12)	204	194	194	-	92,3	29
(10)	196	187	187	-	90,7	28
(8)	188	179	179	-	89,5	27
(6)	180	171	171	-	87,1	26
(4)	173	165	165	-	85,5	25
(2)	166	158	158	-	83,5	24
(0)	160	152	152	-	81,7	24

¹⁾ al carbonio di tungsteno - tungsten carbon material's

Tipologia Type	EUROPA - EUROPE				ASIA - ASIA	
	ISB® Italia - Italy	INA/FAG Germania - Germany	RHP Regno Unito - United Kingdom	SKF Svezia - Sweden	ASAHI Giappone - Japan	FYH Giappone - Japan
Supporti ritti Pillow blocks	UCP 2.., UKP 2.., HCP 2..	RASE, RASES, PASE	NP	SY, SYP, SYJ..TF	UCP, UKP 200	UCP, UKP, NAP 200
	UCLP 2..	-	SL	SYH-X	-	SL 200
	UCP X..	-	MP	-	UCP X00	UCP X00
	UCPH 2.., UKPH 2..	-	-	-	UCPH 200	UCPH 200
	UCPA 2.., UKPA 2.. UP..	SHE -	- -	- -	SYF UP 00	UCPA 200 -
Supporti a flangia Flange units	UCF 2.., UKF 2.., HCF 2..	RCJ, RCJS, PCF	SF, SLF	FY, FYP, FY-X	UCF, UKF 200	UCF 200 SLF 200
	UCF X..	-	MSF	-	UCF X00	UCF X00
	UCFC 2.., UKFC 2.., HCF 2..	-	-	FYC	UCFC, UKFC 200	UCFC 200
	UCFC X..	-	MFC	-	UCFC X00	UCFC X00
	UCFL 2.., UKFL 2.. HCFL 2..	RCJT, RCJTS, PCFT	SFT	FYTB	UCFL 200	UCFL 200
	UCFL X..	-	MSFT	-	UCFL X00	UCFL X00
	UFL..	-	-	-	UFL 00	-
	SAFD 2.. - Sbfd 2..	FLCTE / FLCTEY	-	-	-	-
	SALF 2.. - SBLF 2..	-	-	-	-	ALF-BLF 2
	UCFA 2.., UKFA 2.. UCFB 2.., UKFB 2..	SFT - -	- - -	- - -	- - -	UCFA 200 UCFA 200 UCFK 200 UCFB 200
Supporti scorrevoli Take-up units	UCT 2.., UKT 2.., HCT 2..	PTUE, RTUES	-	-	UCT 200	UCT 200
	UCT X..	-	-	-	UCT X00	UCT X00
Piastra tenditore Stretch-skid	UCT..	-	-	-	WA	UCTH
Supporti a cartuccia Cylindrical cartridge units	UCC 2.., UKC 2.., HCC 2..	-	-	TU	UCC 200	UCC 200
	UCC X..	-	-	-	UCC X00	UCC X00
Supporti pensili Hanger units	UCECH 2.., UKECH 2..	-	SCHB	-	UCECH 200	UCHA 200
Supporti in lamiera stampata Pressed steel bearing units	BPP..	PB	LPB	SP	BPP	SBPP 200 F
	BPF..	RA, RR	SLFE	F	BPF	SBPF 200
	BPFL..	RAT, RRT	SLFL	FT	BPFL	SBPFL 200
	BPFT..	RATR, RRTR	-	-	BPFT	-
Supporti per agricoltura Agricultural units	ST	-	-	-	-	-
Supporti ritti in due metà Bearing housing	SNG 500	-	-	SNH 500	-	-
	SNG 600	-	-	SNH 600	-	-
	SNL 500	-	-	SNL 500	-	-
	SN 500	-	-	-	-	-
	SN 200	-	-	SNH 200	-	-
	SN 300	-	-	SNH 300	-	-
	SD 3000 SD 3100	- -	- -	- SD 3100	- -	- -
Supporti in plastica Plastic bearing units	UCP 2..	PASE, RASEY	-	-	-	-
	UCF 2..	PCJ, RCJY	-	-	-	-
	UCFL 2..	PCJT, RCJTY	-	-	-	-
	UCECH 2..	-	-	-	-	-
	UCPA 2..	-	-	-	-	-
	UCFB 2..	-	-	-	-	-
	SBP 2	-	-	-	-	-
	SBF 2	-	-	-	-	-
	SBFL 2	-	-	-	-	-
Cuscinetti per supporti Bearings for units	UC2..	KRRB	1000 G	YAR	UC 200	UC 200
	HC 2..	GE..KRRB	-	YEL 200	UG 200	NA 200
	UCX..	-	-	-	UCX 00	UCX 00
	UC 3..	-	-	YEL 300	UC 300	UC 300
	UK 2..	GSE..KRRB	1000 G	YSA 200	UK 200	UK 200
	UK 3..	-	-	YSA 300	UK 300	UK 300
	SER 2..	-	-	-	SER 200	ER 200
	SA 2..	RAE..NPPB	12..EC	YET 200	SA 200	SA 200
	SB 2..	AY..NPPB	-	YAT 200	SB 200	SB 200
	RB 2..	-	-	-	-	RB 200
	SC 2 - CB 2 UO..	2..NPPB -	- -	- -	- -	- SC 200

La tabella sopra riportata può essere utilizzata quale riferimento generale per l'intercambiabilità dei supporti e cuscinetti ISB® rispetto ad altre marche. Si raccomanda sempre di verificare con attenzione le dimensioni dei prodotti ISB® rispetto agli stessi articoli di altre marche; alcuni hanno identiche dimensioni, mentre altri possono avere dimensioni diverse. I cuscinetti della serie pesante non sono stati citati in questa tabella, ma sono comunque disponibili per le serie: UCP - UCF - UCFS - UCFL - UCT

ASIA - ASIA				AMERICA - AMERICA		
KOYO Giappone - Japan	NACHI Giappone - Japan	NSK Giappone - Japan	NTN Giappone - Japan	FAFNIR Stati Uniti d'America U.S.A.	LINK-BELT Stati Uniti d'America U.S.A.	SEAL-MASTER Stati Uniti d'America U.S.A.
UCP, UKP 200, GAP 1100B	UCP, UKP+H, UGP, BP 200	UCP, UKP, EWP 200	UCP, UK UELPL 200	RAS, LAS	P3-Y200N	NP
SLP 200	UCLP, FGAK 200	UCPLL, EWPLL 200	UCPL 200	RAK, LAK	PL3-Y200N	S-500-M
UCP X00	UCP, UKP+H X00	UCP X00	UCP X00	RAKH, LAKH	-	MP
-	-	UCPH 200	UCPH 200	-	-	-
UCPA 200, UKPA 200	UCPA 200	UCPA 200	UCUP 200	-	-	-
-	-	UBLP 200	UP 00	-	-	-
UCF 200 GFF 1100	UCF, UKF+H, UGF, BF, UCLF 200	UCF, EWFH 200	UCF 200	RCJ, LCJ	F3-Y200N	SF
UCF X00	UCF, UKF+H X00	UCF X00	UCF X00	RCJO, LCJO	-	MSF
UCFC 200	UCFC, UKFC+H, UGFC, BCF 200	UCFC 200	UCFC 200	-	-	-
UCFC X00	UCF, UKFC+H X00	UCFC X00	UCFC X00	RFC	FC3-Y200N	MFC
UCFL 200 UCFL 1100	UCFL, UKFL+H, UGFL, BFL, UCFT 200	UCFL, EWFLH 200	UCFL 200	FCJT, LCJT	FX3-Y200N	SFT
UCFL X00	UCFL, UKFL+H X00	UCFL X00	UCFL X00	-	-	MSFT
-	-	UBLF 200	UFL 00	-	-	-
-	-	-	ASFD 2	-	-	-
-	-	-	-	-	-	-
UCFA 200 UKFA 200	-	UCFA 200	UCFA 200	-	-	-
UCBF 200	UCFK 200	UCFK 200	UCFH 200	-	-	-
UCT 200	UCT, UKT+H, UGT, BT 200	UCT 200	UCT 200	-	-	-
UCT X00	UCT, UKT+H X00	UCT X00	UCT X00	-	-	-
LV-HT	-	WB	UCT	-	-	-
UCC 200	UCC, UKC+H, UGC, BC 200	UCC 200	UCC 200	-	-	-
UCC X00	UCC, UKC+H X00	UCC X00	UCC X00	-	-	-
SCHB 200	ECECH 200	UCEH 200	UCHB 200	-	-	SEHB
SP	BPP	UBPP 200	ASPP 200	PB	-	SSP
PF	BPF	UBPF 200	ASPF 200	RE, RR	MSC1	SSF
PTF	BPFL	UBPFL 200	ASPFL 200	RAT, RRT	MST	SSFT
PTFR	BPFT	UBPFT 200	-	RATR, RRTR	MSTR	TSSF
-	-	-	-	-	-	-
-	-	-	-	-	-	-
-	-	-	-	-	-	-
-	-	-	-	-	-	-
-	-	-	-	-	-	-
-	-	-	-	-	-	-
-	-	-	-	-	-	-
-	-	-	-	-	-	-
-	-	-	-	-	-	-
-	-	-	-	-	-	-
-	-	-	-	-	-	-
-	-	-	-	-	-	-
-	-	-	-	-	-	-
-	-	-	-	-	-	-
-	-	-	-	-	-	-
-	-	-	-	-	-	-
-	-	-	-	-	-	-
-	-	-	-	-	-	-
-	-	-	-	-	-	-
-	-	-	-	-	-	-
-	-	-	-	-	-	-
UC 200	UC (UCW) 200	UC 200	UC 200	GC1100KRRB	YG 200 N	2-00
-	-	EW 200	UEL 200	G1100KRBB	-	-
UCX 00	UCX 00	UCX 00	UCX 00	GN-KRRB	U300D	3-00
UC 300	UC 300	UC 300	UC 300	-	-	-
UK 200	UK 200	UK 200	UK 200	G-KLLB	YG 200 N	2-00
UK 300	UK 300	UK 300	UK 300	-	-	-
-	SER 200	-	UCS 200	GC-KRRG-2	-	ER
-	KH 200 AE	EN 200	AEL 200	RA..RRB	-	L-00
PB	B	UB 200	AS 200	YA..RRB	-	-
-	-	UR 200	-	-	-	-
CB	-	CS 2.. DDU	CS 2.. LLU	-	-	-
-	-	-	-	-	-	-

The above table should be used as a cross reference for ISB® and other manufacturers of self-aligning bearing units. Please note that some dimensions of the ISB® brand may differ slightly from those of other manufacturers. Heavier duty Pillow Blocks have not been included in this cross reference table. Sizes available are: UCP - UCF - UCFS - UCFL - UCT.

Supporto Housing	Tipologia - Type					
	UC2.. UC3.. UCX..	UK2.. UK3.. UKX..	HC2..	SA2..	SB-RB2..	U0
P	UCP2.. - UCP3.. UCLP2.. - UCPX..	UKP2.. - UKP3.. UKPX..	HCP2..	SAP	SBP	-
F	UCF2.. - UCF3.. UCF53.. - UCFX..	UKF2.. - UKF3.. UKFX..	HCF2..	SAF	SBF	-
FC	UCFC2.. - UCFCX..	UKFC2.. - UKFCX..	HCFC2..	SAFC	SBFC	-
FL	UCFL2.. - UCFL3.. UCFLX..	UKFL2.. - UKFL3.. UKFLX..	HCFL2..	SAFL	SBFL	-
T	UCT2.. - UCT3.. UCTX..	UKT2.. - UKT3.. UKTX..	HCT2..	SAT	SBT	-
C	UCC2.. - UCC3.. UCCX..	UKC2.. - UKC3.. UKCX..	HCC2..	SAC	SBC	-
PH	UCPH2..	UKPH2..	HCPH2..	SAPH	SBPH	-
PA	UCPA2..	UKPA2..	HCPA2..	SAPA	SBPA	-
FA	UCFA2..	UKFA2..	HCFA2..	SAFA	SBFA	-
FB	UCFB2..	UKFB2..	HCFB2..	SAFB	SBFB	-
ECH	UCECH2..	UKECH2..	HCECH2..	SAECH	SBECH	-
LP Alluminio Aluminium	-	-	HCLP2..	SALP	-	UP
LF Alluminio Aluminium	-	-	HCLF2..	SALF2..	-	UFL
FD	-	-	HCFD2..	SAFD2..	SBFD2..	-
LF	-	-	HCLF2..	SALF2..	SBLF2..	-
ST	Supporti agricoli (su richiesta disponibili misure in pollici) - Agricultural bearing units (inches size are available under request)					
PP	BPP..	-	-	BPP-SA2..	BPP-SB2..	-
PF	BPF..	-	-	BPF-SA2..	BPF-SB2..	-
PFL	BPFL..	-	-	BPFL-SA2..	BPFL-SB2..	-
FT	BPFT..	-	-	BPFT-SA2..	BPFT-SB2..	-
SNG-SNL SN-SD	Supporti ritti in due metà - Bearing Housings					
P Plastica Plastic	UCP2..	con cuscinetto UC inox ed in plastica - with plastic or stainless steel UC bearing				
F Plastica Plastic	UCF2..	con cuscinetto UC inox ed in plastica - with plastic or stainless steel UC bearing				
FC Plastica Plastic	UCFC2..	con cuscinetto UC inox ed in plastica - with plastic or stainless steel UC bearing				
FL Plastica Plastic	UCFL2..	con cuscinetto UC inox ed in plastica - with plastic or stainless steel UC bearing				
T Plastica Plastic	UCT2..	con cuscinetto UC inox ed in plastica - with plastic or stainless steel UC bearing				
ECH Plastica Plastic	UCECH2..	con cuscinetto UC inox ed in plastica - with plastic or stainless steel UC bearing				
PA Plastica Plastic	UCPA2..	con cuscinetto UC inox ed in plastica - with plastic or stainless steel UC bearing				
FB Plastica Plastic	UCFB2..	con cuscinetto UC inox ed in plastica - with plastic or stainless steel UC bearing				

Tipo - Type						Pagina Page	
						Supporti <i>Bearing units</i>	44
						Supporti in lamiera <i>Pressed steel bearing units</i>	98
						Cuscinetti <i>Bearings</i>	104
						Supporti ritti in due metà <i>Plummer blocks</i>	118
						Supporti flangiati <i>Housings</i>	141
						Supporti in plastica <i>Plastic bearing units</i>	142
						Supporti per viti a ricircolo di sfere <i>Supports of ball screws</i>	159

I supporti **ISB** possono essere utilizzati non solamente in condizioni di normale temperatura, ma anche in applicazioni con elevate temperature.

Nei supporti **ISB** per Alta Temperatura (**HT**) viene impiegata una speciale tipologia di tenuta e di grasso, appositamente studiati per resistere oltre ai 100° C, come da tabella sotto riportata.

Nell'utilizzo ad elevata temperatura, è necessario considerare che i supporti presentano un calo del carico massimo ammissibile, e un incremento del giuoco radiale rispetto alle normali condizioni d'impiego.

Lo standard di riferimento per il giuoco radiale dei cuscinetti montati in questi supporti è C5 sia per fori cilindrici che conici. In condizioni di elevato differenziale di temperatura tra l'anello interno e l'anello esterno del cuscinetto, occorre prevedere specifici giuochi radiali.

ISB bearing units may be used not only in normal temperature conditions, but also in high temperature applications.

*ISB bearing units for High Temperature (**HT**) use suitable kind of rubber seal and the grease for specific operating temperature as shown in the table reported below.*

For heat resistance application, it must be taken in consideration the decrease of load rating of the bearings and a larger-than-normal radial internal clearance.

Standard radial internal clearances for High Temperature applications are C5 for both cylindrical and tapered bore bearings.

When temperature gap between the inner and the outer ring of the bearing is extremely large, suitable radial internal clearance must be determined.

Intervalli di impiego

Range of operating temperature

Applicazione <i>Application</i>	Temperatura <i>Temperature</i>	Grasso <i>Grease</i>	Tenuta in gomma <i>Rubber seal</i>	Colore schermo <i>Colour of slinger</i>
Standard <i>Standard</i>	-15 ➤ +100°C	A base di litio <i>Lithium-Base Grease 2</i>	NBR	Nero <i>Black</i>
Alta temperatura <i>High Temperature</i>	Fino a +200 °C <i>Up to +200 °C</i>	Egols-8604	Silicone <i>Silicon rubber</i>	Rosso <i>Red</i>

SUPPORTI

BEARING UNITS



SUPPORTI IN LAMIERA

PRESSED STEEL BEARING UNITS



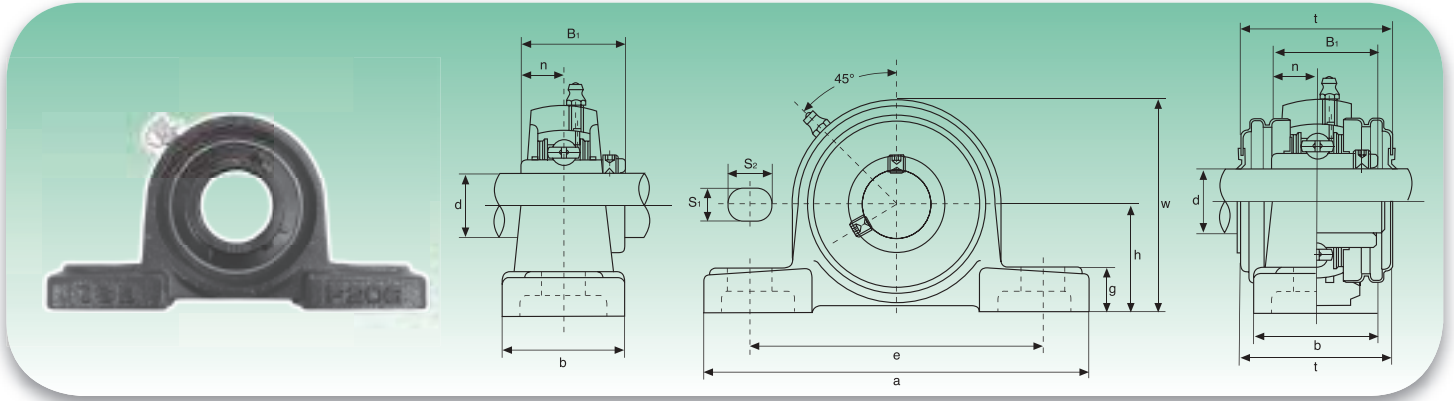

Tipo Type	Dimensioni - Dimensions												Bull. fiss. Bolt Size	Coefficienti di carico (N) Load ratings (N)		Cuscinetto Bearing	Supporto Housing	Peso Weight
	d	h	a	e	b	S ₁	S ₂	g	w	t	B ₁	n		Dinamico C Dynamic C	Statico C ₀ Static C ₀			
	mm/inch													mm/inch				
UCP201 UCP201-8	12 ½	30,2 13/16	127 5	95 3¾	38 1½	13 ½	19 ¾	14 9/16	62 27/16	44,5 1¾	31 1,2205	12,7 0,500	M10 3/8	12160	6318	UC201 UC201-8	P203	0,69 0,69
UCP202 UCP202-9 UCP202-10	15 9/16 5/8	30,2 13/16	127 5	95 3¾	38 1½	13 ½	19 ¾	14 9/16	62 27/16	44,5 1¾	31 1,2205	12,7 0,500	M10 3/8	12160	6318	UC202 UC202-9 UC202-10	P203	0,69 0,69 0,69
UCP203 UCP203-11	17 11/16	30,2 13/16	127 5	95 3¾	38 1½	13 ½	19 ¾	14 9/16	62 27/16	44,5 1¾	31 1,2205	12,7 0,500	M10 3/8	12160	6318	UC203 UC203-11	P203	0,68 0,67
UCP204 UCP204-12	20 ¾	33,3 15/16	127 5	95 3¾	38 1½	13 ½	19 ¾	14 9/16	65 29/16	44,5 1¾	31 1,2205	12,7 0,500	M10 3/8	12160	6318	UC204 UC204-12	P204	0,66 0,66
UCP205 UCP205-13 UCP205-14 UCP205-15 UCP205-16	25 13/16 7/8 15/16 1	36,5 17/16	140 5½	105 41/8	38 1½	13 ½	19 ¾	15 19/32	71 225/32	48 157/64	34,1 1,3425	14,3 0,563	M10 3/8	13300	7457	UC205 UC205-13 UC205-14 UC205-15 UC205-16	P205	0,81 0,85 0,83 0,82 0,81
UCP206 UCP206-17 UCP206-18 UCP206-19 UCP206-20	30 11/16 11/8 13/16 1¼	42,9 111/16	165 6½	121 4¾	48 17/8	17 43/64	20 25/32	17 21/32	84 35/16	53 25/64	38,1 1,5000	15,9 0,626	M14 ½	18525	10735	UC206 UC206-17 UC206-18 UC206-19 UC206-20	P206	1,24 1,27 1,26 1,24 1,23
UCP207 UCP207-20 UCP207-21 UCP207-22 UCP207-23	35 1¼ 15/16 13/8 17/16	47,6 17/8	167 69/16	127 5	48 17/8	17 43/64	20 25/32	18 45/64	93 321/32	59,5 211/32	42,9 1,6890	17,5 0,689	M14 ½	24415	14630	UC207 UC207-20 UC207-21 UC207-22 UC207-23	P207	1,58 1,64 1,61 1,58 1,55
UCP208 UCP208-24 UCP208-25	40 1½ 19/16	49,2 115/16	184 7¼	137 513/32	54 21/8	17 43/64	20 25/32	18 45/64	100 315/16	69 223/32	49,2 1,9370	19 0,748	M14 ½	27645	16910	UC208 UC208-24 UC208-25	P208	1,89 1,93 1,90
UCP209 UCP209-26 UCP209-27 UCP209-28	45 15/8 111/16 1¾	54,0 21/8	190 715/32	146 5¾	54 21/8	17 43/64	20 25/32	20 25/32	106 411/64	69 223/32	49,2 1,9370	19 0,748	M14 ½	32395	20235	UC209 UC209-26 UC209-27 UC209-28	P209	2,14 2,24 2,20 2,14
UCP210 UCP210-29 UCP210-30 UCP210-31 UCP210-32	50 113/16 17/8 115/16 2	57,2 2¼	206 81/8	159 6¼	60 23/8	20 25/32	23 29/32	21 53/64	113 429/64	74,5 215/16	51,6 2,0315	19 0,748	M16 5/8	33345	22135	UC210 UC210-29 UC210-30 UC210-31 UC210-32	P210	2,66 2,78 2,73 2,68 2,64
UCP211 UCP211-32 UCP211-33 UCP211-34 UCP211-35	55 2 21/16 21/8 23/16	63,5 2½	219 85/8	171 647/64	60 23/8	20 25/32	23 29/32	23 29/32	125 459/64	76 3	55,6 2,1890	22,2 0,874	M16 5/8	41230	27930	UC211 UC211-32 UC211-33 UC211-34 UC211-35	P211	3,31 3,46 3,40 3,35 3,29
UCP212 UCP212-36 UCP212-37 UCP212-38 UCP212-39	60 2¼ 25/16 23/8 27/16	69,8 2¾	241 9½	184 7¼	70 234	20 25/32	23 29/32	25 63/64	138 57/16	89 3½	65,1 2,5630	25,4 1,000	M16 5/8	49780	34390	UC212 UC212-36 UC212-37 UC212-38 UC212-39	P212	4,90 5,03 4,95 4,88 4,81
UCP213 UCP213-40 UCP213-41	65 2½ 29/16	76,2 3	265 107/16	203 8	70 2¾	25 63/64	28 13/32	27 11/16	150 529/32	89 3½	65,1 2,5630	25,4 1,000	M20 ¾	54340	38095	UC213 UC213-40 UC213-41	P213	5,15 5,24 5,15
UCP214 UCP214-42 UCP214-43 UCP214-44	70 25/8 211/16 2¾	79,4 31/8	266 1015/32	210 817/64	72 227/32	25 63/64	28 13/32	27 11/16	156 69/64	-	74,6 2,9370	30,2 1,189	M20 ¾	59090	41895	UC214 UC214-42 UC214-43 UC214-44	P214	6,20 6,41 6,31 6,21
UCP215 UCP215-45 UCP215-46 UCP215-47 UCP215-48	75 213/16 27/8 215/16 3	82,6 3¾	275 1053/64	217 835/64	74 229/32	25 63/64	28 13/32	28 13/32	162 63/8	-	77,8 3,0630	33,3 1,311	M20 ¾	64030	45885	UC215 UC215-45 UC215-46 UC215-47 UC215-48	P215	7,16 7,41 7,30 7,19 7,07
UCP216 UCP216-49 UCP216-50 UCP216-51	80 31/16 31/8 33/16	88,9 3½	292 11½	232 91/8	78 31/16	25 63/64	28 13/32	30 13/16	174 627/32	-	82,6 3,2520	33,3 1,311	M20 ¾	69065	50350	UC216 UC216-49 UC216-50 UC216-51	P216	8,10 8,28 8,15 8,02
UCP217 UCP217-52 UCP217-53 UCP217-55	85 ¾ 35/16 37/16	95,2 3¾	310 1213/64	247 923/32	83 317/64	25 63/64	28 13/32	32 1¼	185 79/32	-	85,7 3,3740	34,1 1,343	M20 ¾	79800	58805	UC217 UC217-52 UC217-53 UC217-55	P217	9,81 10,03 9,89 9,60
UCP218 UCP218-56	90 ¾	101,6 4	327 127/8	262 105/16	88 315/32	27 11/16	30 13/16	33 119/64	198 751/64	-	96 3,7795	39,7 1,5630	M22 7/8	91295	67925	UC218 UC218-56	P218	11,96 12,07

Disponibile in acciaio inox Supporto: AISI 304 - Cuscinetto: AISI 440C o 420C - Available stainless steel Housing: AISI 304 - Bearing: AISI 440C or 420C
Disponibile su richiesta con cuscinetto SA (SAP.) - Available under request with SA bearing (SAP.)

HCP2 Serie normale - Standard duty

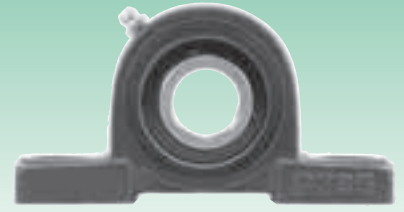
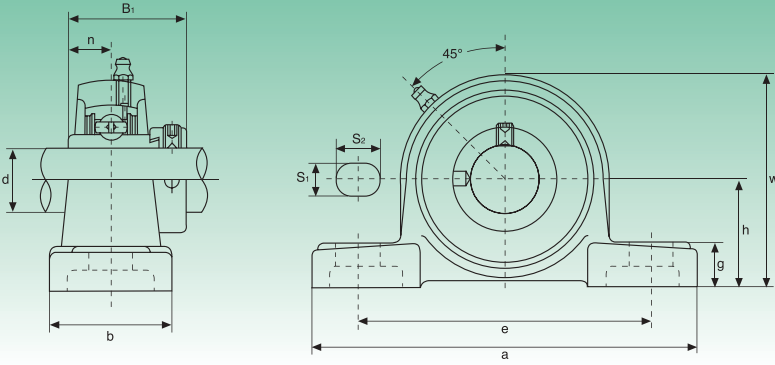

Tipo Type	Dimensioni - Dimensions											Bull. fiss. Bolt Size	Coefficients di carico (N) Load ratings (N)		Cuscinetto Bearing	Supporto Housing	Peso Weight
	d	h	a	e	b	S ₁	S ₂	g	w	B ₁	n		Dinamico C Dynamic C	Statico C ₀ Static C ₀			
	mm/inch												mm/inch				
HCP204	20	33,3	127	95	38	13	19	14	65	43,7	17,1	M10	12160	6318	HC204	P204	0,73
HCP204-12	1 1/4	15/16	5	3 3/4	1 1/2	1/2	3/4	9/16	29/16	1,720	0,673	3/8					0,73
HCP205	25	36,5	140	105	38	13	19	15	71	44,4	17,5	M10	13300	7457	HC205	P205	0,88
HCP205-13	13/16	17/16	5 1/2	41/8	1 1/2	1/2	3/4	19/32	225/32	1,748	0,689	3/8					0,93
HCP205-14	7/8																0,92
HCP205-15	15/16																0,90
HCP205-16	1																0,88
HCP206	30																42,9
HCP206-17	11/16	111/16	6 1/2	4 3/4	17/8	43/64	25/32	21/32	35/16	1,906	0,720	1/2	1,42				
HCP206-18	11/8												1,39				
HCP206-19	13/16												1,37				
HCP206-20	1 1/4												1,34				
HCP207	35	47,6	167	127	48	17	20	18	93	51,1	18,8	M14	24415	14630	HC207	P207	1,70
HCP207-20	1 1/4	17/8	69/16	5	17/8	43/64	25/32	45/64	321/32	2,012	0,740	1/2					1,77
HCP207-21	15/16																1,73
HCP207-22	13/8																1,70
HCP207-23	17/16																1,67
HCP208	40	49,2	184	137	54	17	20	18	100	56,3	21,4	M14	27645	16910	HC208	P208	2,04
HCP208-24	1 1/2	115/16	7 1/4	513/32	21/8	43/64	25/32	45/64	315/16	2,217	0,843	1/2					2,09
HCP208-25	19/16																2,05
HCP209	45	54,0	190	146	54	17	20	20	106	56,3	21,4	M14	32395	20235	HC209	P209	2,31
HCP209-26	15/8	21/8	715/32	5 3/4	21/8	43/64	25/32	25/32	411/64	2,217	0,843	1/2					2,42
HCP209-27	111/16																2,37
HCP209-28	1 3/4																2,33
HCP210	50	57,2	206	159	60	20	23	21	113	62,7	24,6	M16	33345	22135	HC210	P210	2,85
HCP210-29	113/16	2 1/4	81/8	6 3/4	23/8	25/32	29/32	53/64	429/64	2,469	0,969	5/8					3,00
HCP210-30	17/8																2,94
HCP210-31	115/16																2,88
HCP210-32	2																2,82
HCP211	55	63,5	219	171	60	20	23	23	125	71,4	27,8	M16	41230	27930	HC211	P211	3,52
HCP211-32	2	2 1/2	85/8	647/64	23/8	25/32	29/32	29/32	459/64	2,811	1,094	5/8					3,72
HCP211-33	21/16																3,64
HCP211-34	21/8																3,57
HCP211-35	23/16																3,49
HCP212	60	69,8	241	184	70	20	23	25	138	77,8	31	M16	49780	34390	HC212	P212	5,24
HCP212-36	2 1/4	2 3/4	9 1/2	7 1/4	234	25/32	29/32	63/64	57/16	3,063	1,220	5/8					5,40
HCP212-37	25/16																5,31
HCP212-38	23/8																5,26
HCP212-39	27/16																5,13
HCP213	65	76,2	265	203	70	25	28	27	150	85,7	34,1	M20	54340	38095	HC213	P213	5,71
HCP213-40	2 1/2	3	107/16	8	2 3/4	63/64	13/32	11/16	529/32	3,374	1,343	3/4					5,81
HCP213-41	29/16																5,70
HCP214	70	79,4	266	210	72	25	28	27	156	85,7	34,1	M20	59090	41895	HC214	P214	6,70
HCP214-42	25/8	31/8	1015/32	817/64	227/32	63/64	13/32	11/16	69/64	3,374	1,343	3/4					6,94
HCP214-43	211/16																6,83
HCP214-44	2 3/4																6,71
HCP215	75	82,6	275	217	74	25	28	28	162	92,1	37,3	M20	64030	45885	HC215	P215	7,79
HCP215-45	213/16	3 1/4	1053/64	835/64	229/32	63/64	13/32	13/32	63/8	3,626	1,426	3/4					8,09
HCP215-46	27/8																7,96
HCP215-47	215/16																7,83
HCP215-48	3																7,69

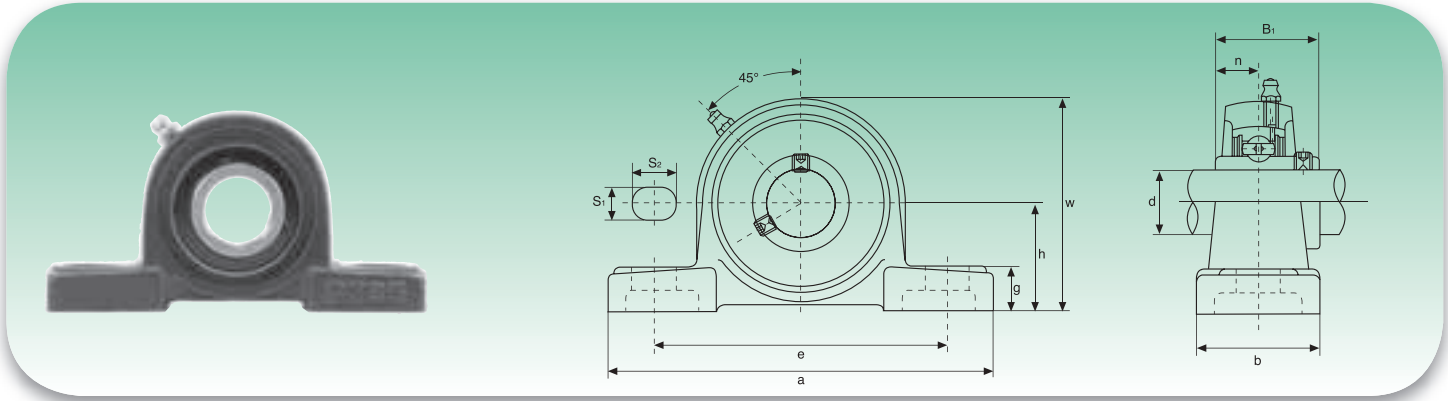

Tipo Type	Dimensioni - Dimensions											Bull. fiss. Bolt Size	Coefficienti di carico (N) Load ratings (N)		Cuscinetto Bearing	Supporto Housing	Peso Weight	
	d	h	a	e	b	S ₁	S ₂	g	w	B ₁	n		Dinamico C Dynamic C	Statico C ₀ Static C ₀				kg
	mm/inch												mm/inch					
UCLP201 UCLP201-8	12 ½	31,75 1¼	127 5	95 3¾	38 1½	13 ½	16 5/8	14 9/16	64 233/64	31 1,2205	12,7 0,500	M10 3/8	12160	6318	UC201 UC201-8	LP204	0,69 0,69	
UCLP202 UCLP202-9 UCLP202-10	15 9/16 5/8	31,75 1¼	127 5	95 3¾	38 1½	13 ½	16 5/8	14 9/16	64 233/64	31 1,2205	12,7 0,500	M10 3/8	12160	6318	UC202 UC202-9 UC202-10	LP204	0,69 0,69 0,69	
UCLP203 UCP203-11	17 11/16	31,75 1¼	127 5	95 3¾	38 1½	13 ½	16 5/8	14 9/16	64 233/64	31 1,2205	12,7 0,500	M10 3/8	12160	6318	UC203 UC203-11	LP204	0,68 0,67	
UCLP204 UCP204-12	20 ¾	31,75 1¼	127 5	95 3¾	38 1½	13 ½	16 5/8	14 9/16	64 233/64	31 1,2205	12,7 0,500	M10 3/8	12160	6318	UC204 UC204-12	LP204	0,66 0,66	
UCLP205 UCLP205-13 UCLP205-14 UCLP205-15 UCLP205-16	25 13/16 7/8 15/16 1	33,34 15/16	140 5½	105 41/8	38 1½	13 ½	16 5/8	15 19/32	68 243/64	34,1 1,3425	14,3 0,563	M10 3/8	13300	7457	UC205 UC205-13 UC205-14 UC205-15 UC205-16	LP205	0,81 0,85 0,83 0,82 0,81	
UCLP206 UCLP206-17 UCLP206-18 UCLP206-19 UCLP206-20	30 11/16 11/8 13/16 1¼	39,69 19/16	165 6½	121 4¾	48 17/8	17 43/64	20 25/32	17 21/32	80 35/32	38,1 1,5000	15,9 0,626	M14 ½	18525	10735	UC206 UC206-17 UC206-18 UC206-19 UC206-20	LP206	1,24 1,27 1,26 1,24 1,23	
UCLP207 UCLP207-20 UCLP207-21 UCLP207-22 UCLP207-23	35 1¼ 15/16 13/8 17/16	46,04 69/16	167 5	127 17/8	48 43/64	17 25/32	20 25/32	18 45/64	91 337/64	42,9 1,6890	17,5 0,689	M14 ½	24415	14630	UC207 UC207-20 UC207-21 UC207-22 UC207-23	LP207	1,58 1,64 1,61 1,58 1,55	
UCLP208 UCLP208-24 UCLP208-25	40 1½ 19/16	49,2 115/16	184 7¼	137 513/32	54 21/8	17 43/64	20 25/32	18 45/64	100 315/16	49,2 1,9370	19 0,748	M14 ½	27645	16910	UC208 UC208-24 UC208-25	LP208	1,89 1,93 1,90	
UCLP209 UCLP209-26 UCLP209-27 UCLP209-28	45 15/8 111/16 1¾	52,39 21/16	190 715/32	146 5¾	54 21/8	17 43/64	20 25/32	20 25/32	104 43/32	49,2 1,9370	19 0,748	M14 ½	32395	20235	UC209 UC209-26 UC209-27 UC209-28	LP209	2,14 2,24 2,20 2,14	
UCLP210 UCLP210-29 UCLP210-30 UCLP210-31 UCLP210-32	50 113/16 17/8 115/16 2	55,56 23/16	206 81/8	159 6¾	60 23/8	20 25/32	23 29/32	21 53/64	112 413/32	51,6 2,0315	19 0,748	M16 5/8	33345	22135	UC210 UC210-29 UC210-30 UC210-31 UC210-32	LP210	2,66 2,78 2,73 2,68 2,64	
UCLP211 UCLP211-32 UCLP211-33 UCLP211-34 UCLP211-35	55 2 21/16 21/8 23/16	61,91 27/16	219 85/8	171 647/64	60 23/8	20 25/32	23 29/32	23 29/32	124 47/8	55,6 2,1890	22,2 0,874	M16 5/8	41230	27930	UC211 UC211-32 UC211-33 UC211-34 UC211-35	LP211	3,31 3,46 3,40 3,35 3,29	
UCLP212 UCLP212-36 UCLP212-37 UCLP212-38 UCLP212-39	60 2¼ 25/16 23/8 27/16	68,26 211/16	241 9½	184 7¼	70 234	20 25/32	23 29/32	25 63/64	136 523/64	65,1 2,5630	25,4 1,000	M16 5/8	49780	34390	UC212 UC212-36 UC212-37 UC212-38 UC212-39	LP212	4,90 5,03 4,95 4,88 4,81	

UCP3 Serie pesante - Heavy duty

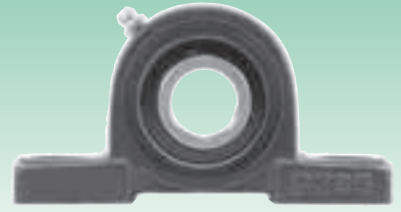
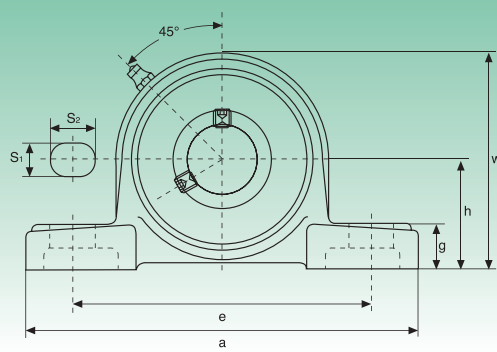
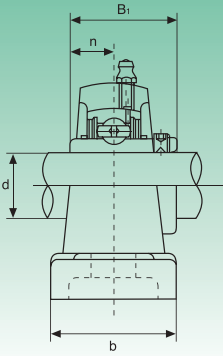

Tipo Type	Dimensioni - Dimensions											Bull. fiss. Bolt Size	Coefficients di carico (N) Load ratings (N)		Cuscinetto Bearing	Supporto Housing	Peso Weight	
	d	h	a	e	b	S ₁	S ₂	g	w	B ₁	n		Dinamico C Dynamic C	Statico C ₀ Static C ₀				kg
	mm/inch												mm/inch					
UCP305 UCP305-13 UCP305-14 UCP305-15 UCP305-16	25 13/16 7/8 15/16 1	45	175	132	45	17	20	15	85	38	15	M14 1/2	20140	10355	UC305 UC305-13 UC305-14 UC305-15 UC305-16	P305	1,4	
UCP306 UCP306-17 UCP306-18 UCP306-19	30 11/16 11/8 13/16	50	180	140	50	17	20	18	95	43	17	M14 1/2	25365	14250	UC306 UC306-17 UC306-18 UC306-19	P306	1,8	
UCP307 UCP307-20 UCP307-21 UCP307-22 UCP307-23	35 1 1/4 15/16 13/8 17/16	56	210	160	56	17	25	20	106	48	19	M14 1/2	31730	18335	UC307 UC307-20 UC307-21 UC307-22 UC307-23	P307	2,8	
UCP308 UCP308-24 UCP308-25	40 1 1/2 19/16	60	220	170	60	17	27	22	116	52	19	M14 1/2	38665	22800	UC308 UC308-24 UC308-25	P308	3,0	
UCP309 UCP309-26 UCP309-27 UCP309-28	45 15/8 111/16 1 3/4	67	245	190	67	20	30	24	129	57	22	M16 5/8	46455	28025	UC309 UC309-26 UC309-27 UC309-28	P309	4,1	
UCP310 UCP310-29 UCP310-30 UCP310-31	50 113/16 17/8 115/16	75	275	212	75	20	35	27	143	61	22	M16 5/8	58900	36385	UC310 UC310-29 UC310-30 UC310-31	P310	5,8	
UCP311 UCP311-32 UCP311-33 UCP311-34 UCP311-35	55 2 21/16 21/8 23/16	80	310	236	80	20	38	30	154	66	25	M16 5/8	68020	42750	UC311 UC311-32 UC311-33 UC311-34 UC311-35	P311	7,4	
UCP312 UCP312-36 UCP312-37 UCP312-38 UCP312-39	60 2 1/4 25/16 23/8 27/16	85	330	250	85	25	38	32	165	71	26	M20 3/4	77805	49590	UC312 UC312-36 UC312-37 UC312-38 UC312-39	P312	9,4	
UCP313 UCP313-40 UCP313-41	65 2 1/2 29/16	90	340	260	90	25	38	33	176	75	30	M20 3/4	88065	56905	UC313 UC313-40 UC313-41	P313	10	
UCP314 UCP314-42 UCP314-43 UCP314-44	70 25/8 211/16 2 3/4	95	360	280	90	27	40	35	187	78	33	M22 7/8	98800	64790	UC314 UC314-42 UC314-43 UC314-44	P314	12	
UCP315 UCP315-45 UCP315-46 UCP315-47 UCP315-48	75 216/8 27/8 215/16 3	100	380	290	100	27	40	35	198	82	32	M22 7/8	107350	73340	UC315 UC315-45 UC315-46 UC315-47 UC315-48	P315	14	
UCP316 UCP316-49 UCP316-50 UCP316-51	80 31/16 31/8 33/16	106	400	300	110	27	40	40	210	86	34	M22 7/8	111850	82365	UC316 UC316-49 UC316-50 UC316-51	P316	18	
UCP317 UCP317-52 UCP317-53 UCP317-55	85 3 3/4 35/16 37/16	112	420	320	110	33	45	40	220	96	40	M27 1	126350	91960	UC317 UC317-52 UC317-53 UC317-55	P317	20	
UCP318 UCP318-55 UCP318-56	90 37/16 3 1/2	118	430	330	110	33	45	45	235	96	40	M27 1	135850	101650	UC318 UC318-55 UC318-56	P318	24	
UCP319 UCP319-58 UCP319-59 UCP319-60	95 35/8 311/16 3 3/4	125	470	360	120	36	50	45	250	103	41	M30 11/8	145350	113050	UC319 UC319-58 UC319-59 UC319-60	P319	29	
UCP320 UCP320-64	100 4	140	490	380	120	36	50	50	275	108	42	M30 11/8	164350	133950	UC320 UC320-64	P320	35	
UCP321	105	140	490	380	120	36	50	56	283	112	44	M33	174800	145350	UC321	P321	35	
UCP322	110	150	520	400	140	40	55	61	303	117	46	M33	194750	171000	UC322	P322	45	
UCP324	120	160	570	450	140	40	55	71	323	126	51	M33	196650	175750	UC324	P324	55	
UCP326	130	180	600	480	140	40	55	81	363	135	54	M33	217550	203300	UC326	P326	72	
UCP328	140	200	620	500	140	40	55	81	403	145	59	M33	240350	233700	UC328	P328	89	

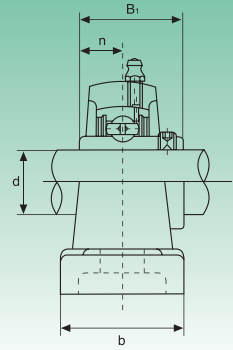
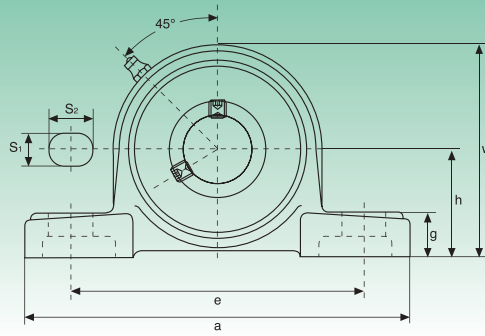

Tipo Type	Dimensioni - Dimensions											Bull. fiss. Bolt Size	Coefficienti di carico (N) Load ratings (N)		Cuscinetto Bearing	Supporto Housing	Peso Weight
	d	h	a	e	b	S ₁	S ₂	g	w	B ₁	n		Dinamico C Dynamic C	Statico C ₀ Static C ₀			
	mm/inch												mm/inch				
UCPX05 UCPX05-13 UCPX05-14 UCPX05-15 UCPX05-16	25 13/16 7/8 15/16 1	44,4 1 3/4	159 6 1/4	119 4 11/16	51 2	17 43/64	20 25/32	18 23/32	85 3 11/32	38,1 1,5000	15,9 0,626	M14 1/2	18525	10735	UCX05 UCX05-13 UCX05-14 UCX05-15 UCX05-16	PX05	1,5
UCPX06 UCPX06-17 UCPX06-18 UCPX06-19 UCPX06-20	30 1 1/16 1 1/8 1 3/16 1 1/4	47,6 1 7/8	175 6 7/8	127 5	57 2 1/4	17 43/64	20 25/32	20 25/32	93 3 31/32	42,9 1,6890	17,5 0,689	M14 1/2	24415	14630	UCX06 UCX06-17 UCX06-18 UCX06-19 UCX06-20	PX06	2,0
UCPX07 UCPX07-21 UCPX07-22 UCPX07-23	35 1 5/16 1 3/8 1 7/16	54,0 2 1/8	203 8	144 5 21/32	57 2 1/4	17 43/64	20 25/32	21 13/16	105 4 1/8	49,2 1,9370	19 0,748	M14 1/2	27645	16910	UCX07 UCX07-21 UCX07-22 UCX07-23	PX07	2,6
UCPX08 UCPX08-24 UCPX08-25	40 1 1/2 1 9/16	58,7 2 5/16	222 8 3/4	156 6 5/32	67 2 5/8	20 25/32	23 29/32	26 1 1/32	111 4 3/8	49,2 1,9370	19 0,748	M16 5/8	32395	20235	UCX08 UCX08-24 UCX08-25	PX08	3,3
UCPX09 UCPX09-26 UCPX09-27 UCPX09-28 UCPX09-29	45 1 5/8 1 11/16 1 3/4 1 13/16	58,7 2 5/16	222 8 3/4	156 6 5/32	67 2 5/8	20 25/32	23 29/32	26 1 1/32	116 4 9/16	51,6 2,0315	19 0,748	M16 5/8	33345	22135	UCX09 UCX09-26 UCX09-27 UCX09-28 UCX09-29	PX09	3,3
UCPX10 UCPX10-30 UCPX10-31 UCPX10-32	50 1 7/8 1 11/16 2	63,5 2 1/2	241 9 1/2	171 6 47/64	73 2 7/8	20 25/32	23 29/32	27 1 1/16	126 4 31/32	55,6 2,1890	22,2 0,874	M16 5/8	41230	27930	UCX10 UCX10-30 UCX10-31 UCX10-32	PX10	4,3
UCPX11 UCPX11-33 UCPX11-34 UCPX11-35 UCPX11-36 UCPX11-37	55 2 1/16 2 1/8 2 3/16 2 1/4 2 5/16	69,8 2 3/4	260 10 1/4	184 7 1/4	79 3 1/8	25 31/32	28 13/32	30 1 3/16	137 5 13/32	65,1 2,5630	25,4 1,000	M20 3/4	49780	34390	UCX11 UCX11-33 UCX11-34 UCX11-35 UCX11-36 UCX11-37	PX11	5,7
UCPX12 UCPX12-38 UCPX12-39	60 2 3/8 2 7/16	76,2 3	286 11 1/4	203 8	83 3 9/32	25 31/32	28 13/32	33 1 5/16	151 5 15/16	65,1 2,5630	25,4 1,000	M20 3/4	54340	38095	UCX12 UCX12-38 UCX12-39	PX12	7,3
UCPX13 UCPX13-40 UCPX13-41	65 2 1/2 2 9/16	76,2 3	286 11 1/4	203 8	83 3 9/32	25 63/64	28 13/32	33 1 5/16	154 6 1/16	74,6 2,9370	30,2 1,189	M20 3/4	59090	41895	UCX13 UCX13-40 UCX13-41	PX13	7,6
UCPX14 UCPX14-42 UCPX14-43 UCPX14-44	70 2 5/8 2 11/16 2 3/4	88,9 3 1/2	330 13	229 9 1/32	89 3 1/2	27 1 1/16	30 1 3/16	35 1 3/8	170 6 11/16	77,8 3,0630	33,3 1,311	M22 7/8	64030	45885	UCX14 UCX14-42 UCX14-43 UCX14-44	PX14	9,9
UCPX15 UCPX15-45 UCPX15-46 UCPX15-47 UCPX15-48	75 2 13/16 2 7/8 2 15/16 3	88,9 3 1/2	330 13	229 9 1/32	89 3 1/2	27 1 1/16	30 1 3/16	35 1 3/8	175 6 7/8	82,6 3,2520	33,3 1,311	M22 7/8	69065	50350	UCX15 UCX15-45 UCX15-46 UCX15-47 UCX15-48	PX15	11
UCPX16 UCPX16-49 UCPX16-50 UCPX16-51 UCPX16-52	80 3 1/16 3 1/8 3 3/16 3 3/4	101,6 4	381 15	283 1 15/32	102 4 1/32	27 1 1/16	30 1 3/16	40 1 9/16	194 7 5/8	85,7 3,3740	34,1 1,343	M22 7/8	79800	58805	UCX16 UCX16-49 UCX16-50 UCX16-51 UCX16-52	PX16	15
UCPX17 UCPX17-53 UCPX17-55	85 3 5/16 3 7/16	101,6 4	381 15	283 1 15/32	102 4 1/32	27 1 1/16	30 1 3/16	40 1 9/16	200 7 7/8	96 3,7795	39,7 1,563	M22 7/8	91295	67925	UCX17 UCX17-53 UCX17-55	PX17	16
UCPX18 UCPX18-56 UCPX18-57	90 3 7/16 3 3/2	101,6 4	381 15	283 1 15/32	111 4 3/8	27 1 1/16	30 1 3/16	40 1 9/16	206 8 1/8	104 4,0945	42,9 1,689	M22 7/8	103550	77805	UCX18 UCX18-56 UCX18-57	PX18	17
UCPX20 UCPX20-58 UCPX20-59 UCPX20-60 UCPX20-61	100 3 13/16 3 7/8 3 15/16 4	127 5	432 17	337 1 39/32	121 4 3/4	33 15/16	36 1 13/32	45 1 25/32	244 9 19/32	117,5 4,6260	49,2 1,937	M27 1	126350	99750	UCX20 UCX20-58 UCX20-59 UCX20-60 UCX20-61	PX20	30

UKP2 Serie normale - Standard duty

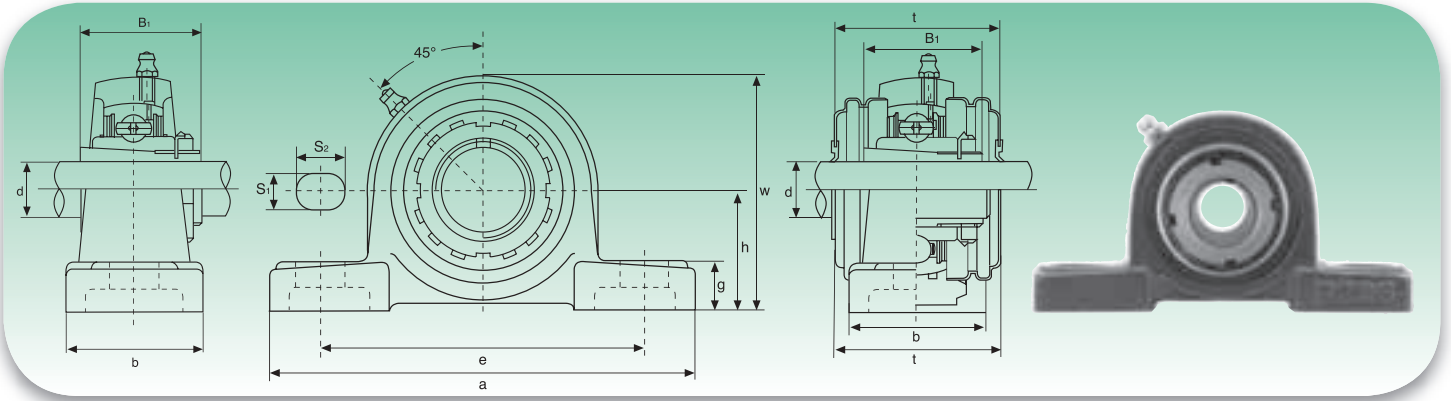

Tipo Type	Dimensioni - Dimensions											Bull. fiss. Bolt Size	Coefficienti di carico (N) Load ratings (N)		Cuscinetto Bearing	Supporto Housing	Peso Weight	
	d	h	a	e	b	S ₁	S ₂	g	w	t	B ₁		Dinamico C Dynamic C	Statico C ₀ Static C ₀				kg
	mm/inch												mm/inch					
UKP205+H2305	20	36,5	140	105	38	13	19	15	71	48	35	M10	13300	7457	UK205+H2305	P205	0,86	
UKP205+HE2305	¾	17/16	5½	41/8	1½	½	¾	19/32	225/32	157/64	1,378	3/8			UK205+HE2305			
UKP206+H2306	25	42,9	165	121	48	17	20	17	84	53	38	M14	18525	10735	UK206+H2306	P206	1,28	
UKP206+HS2306	7/8	111/16	6½	4¾	17/8	43/64	25/32	43/64	35/16	25/64	1,496	½			UK206+HS2306			
UKP206+HE2306	1												UK206+HE2306					
UKP207+H2307	30	47,6	167	127	48	17	20	18	93	59,5	43	M14	24415	14630	UK207+H2307	P207	1,67	
UKP207+HS2307	11/8	17/8	69/16	5	17/8	43/64	25/32	45/64	321/32	211/32	1,693	½			UK207+HS2307			
UKP208+H2308	35	49,2	184	137	54	17	20	18	100	69	46	M14	27645	16910	UK208+H2308	P208	1,99	
UKP208+HE2308	1¼	115/16	7¼	513/32	21/8	43/64	25/32	45/64	315/16	223/32	1,811	½			UK208+HE2308			
UKP208+HS2308	13/8												UK208+HS2308					
UKP209+H2309	40	54	190	146	54	17	20	20	106	69	50	M14	32395	20235	UK209+H2309	P209	1,29	
UKP209+HA2309	17/16	21/8	715/32	5¾	21/8	43/64	25/32	25/32	411/64	223/32	1,969	½			UK209+HA2309			
UKP209+HE2309	1½												UK209+HE2309					
UKP209+HS2309	15/8	UK209+HS2309																
UKP210+H2310	45	57,2	206	159	60	20	23	21	113	74,5	55	M16	33345	22135	UK210+H2310	P210	2,83	
UKP210+HS2310	15/8	2¼	81/8	6¾	23/8	25/32	29/32	53/64	429/64	215/16	2,165	5/8			UK210+HS2310			
UKP210+HA2310	111/16												UK210+HA2310					
UKP210+HE2310	1¾	UK210+HE2310																
UKP211+H2311	50	63,5	219	171	60	20	23	23	125	76	59	M16	41230	27930	UK211+H2311	P211	3,46	
UKP211+HS2311	17/8	2½	85/8	647/64	23/8	25/32	29/32	29/32	459/64	3	2,323	5/8			UK211+HS2311			
UKP211+HA2311	115/16												UK211+HA2311					
UKP211+HE2311	2	UK211+HE2311																
UKP212+H2312	55	69,8	241	184	70	20	23	25	138	89	62	M16	49780	34390	UK212+H2312	P212	4,95	
UKP212+HS2312	21/8	2¾	9½	7¼	2¾	25/32	29/32	63/64	57/16	3½	2,441	5/8			UK212+HS2312			
UKP213+H2313	60	76,2	265	203	70	25	28	27	150	89	65	M20	54340	38095	UK213+H2313	P213	5,06	
UKP213+HA2313	23/16	3	107/16	8	2¾	63/64	13/32	11/16	529/32	3½	2,559	¾			UK213+HA2313			
UKP213+HE2313	2¼												UK213+HE2313					
UKP213+HS2313	23/8	UK213+HS2313																
UKP215+H2315	65	82,6	275	217	74	25	28	28	162	-	73	M20	64030	45885	UK215+H2315	P215	7,27	
UKP215+HA2315	27/16	3¼	1053/64	835/64	229/32	63/64	13/32	13/32	63/8	-	2,874	¾			UK215+HA2315			
UKP215+HE2315	2½	UK215+HE2315																
UKP216+H2316	70	88,9	292	232	78	25	28	30	174	-	78	M20	69065	50350	UK216+H2316	P216	8,36	
UKP216+HA2316	211/16	3½	11½	91/8	31/16	63/64	13/32	13/16	627/32	-	3,071	¾			UK216+HA2316			
UKP216+HE2316	2¾	UK216+HE2316																
UKP217+H2317	75	95,2	310	247	83	25	28	32	185	-	82	M20	79800	58805	UK217+H2317	P217	10,23	
UKP217+HA2317	215/16	3¾	1213/64	923/32	317/64	63/64	13/32	1¼	79/32	-	3,228	¾			UK217+HA2317			
UKP217+HE2317	3	UK217+HE2317																
UKP218+H2318	80	101,6	327	262	88	27	30	33	198	-	86	M22	91295	67925	UK218+H2318	P218	12,34	
UKP218+HA2318	33/16	4	127/8	105/16	315/32	11/16	13/16	119/64	751/64	-	3,386	7/8			UK218+HA2318			

Bussole HA; HE; HS con filettatura in pollici
Inch dimension adapter sleeves HA; HE; HS

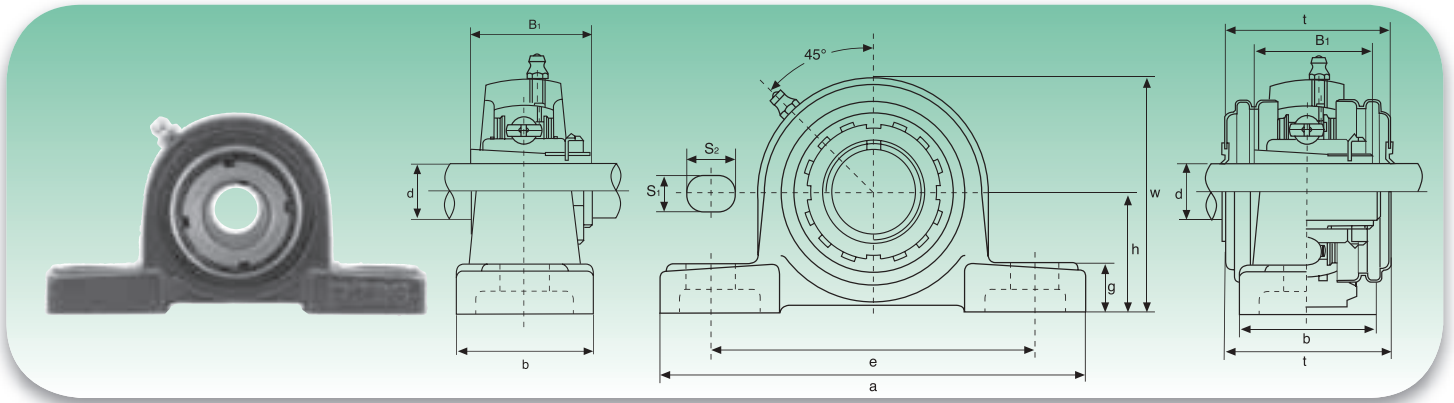

Tipo Type	Dimensioni - Dimensions										Bull. fiss. Bolt Size	Coefficienti di carico (N) Load ratings (N)		Cuscinetto Bearing	Supporto Housing	Peso Weight	
	d	h	a	e	b	S ₁	S ₂	g	w	B ₁		Dinamico C Dynamic C	Statico C ₀ Static C ₀				kg
	mm/inch											mm/inch					
UKP305+H2305 UCP305+HE2305	20 ¾	45 149/64	175 67/8	132 53/16	45 1¾	17 43/64	20 19/32	15 25/32	85 311/32	35 1,378	M14 ½	20140	10355	UK305+H2305 UK305+HE2305	P305	1,7	
UKP306+H2306 UKP306+HS2306 UKP306+HE2306	25 7/8 1	50 131/32	180 73/32	140 5½	50 131/32	17 43/64	20 25/32	18 23/32	95 3¾	38 1,496	M14 ½	25365	14250	UK306+H2306 UK306+HS2306 UK306+HE2306	P306	2,3	
UKP307+H2307 UKP307+HS2307	30 11/8	56 213/64	210 89/32	160 65/16	56 27/32	17 43/64	25 63/64	20 25/32	106 43/16	43 1,693	M14 ½	31730	18335	UK307+H2307 UK307+HS2307	P307	3,0	
UKP308+H2308 UKP308+HE2308 UKP308+HS2308	35 1¼ 13/8	60 223/64	220 821/32	170 611/16	60 23/8	17 43/64	27 11/16	22 7/8	116 49/16	46 1,811	M16 5/8	38665	22800	UK308+H2308 UK308+HE2308 UK308+HS2308	P308	3,8	
UKP309+H2309 UKP309+HA2309 UKP309+HE2309 UKP309+HS2309	40 17/16 1½ 15/8	67 141/64	245 921/32	190 715/32	67 25/8	20 25/32	30 13/16	24 15/16	129 53/32	50 1,969	M16 5/8	46455	28025	UK309+H2309 UK309+HA2309 UK309+HE2309 UK309+HS2309	P309	5,0	
UKP310+H2310 UKP310+HS2310 UKP310+HA2310 UKP310+HE2310	45 15/8 111/16 1¾	75 261/64	275 1013/16	212 811/32	75 215/16	20 25/32	35 13/8	27 11/16	143 55/8	55 2,165	M16 5/8	58900	36385	UK310+H2310 UK310+HS2310 UK310+HA2310 UK310+HE2310	P310	6,7	
UKP311+H2311 UKP311+HS2311 UKP311+HA2311 UKP311+HE2311	50 17/8 115/16 2	80 35/32	310 127/32	236 99/32	80 35/32	20 25/32	38 1½	30 13/16	154 61/16	59 2,323	M16 5/8	68020	42750	UK311+H2311 UK311+HS2311 UK311+HA2311 UK311+HE2311	P311	8,1	
UKP312+H2312 UKP312+HS2312	55 21/8	85 311/32	330 12	250 927/32	85 311/32	25 63/64	38 1½	32 1¼	165 6½	62 2,441	M20 ¾	77805	49590	UK312+H2312 UK312+HS2312	P312	9,4	
UKP313+H2313 UKP313+HA2313 UKP313+HE2313 UKP313+HS2313	60 23/16 2¼ 23/8	90 335/64	340 133/8	260 10¼	90 317/32	25 63/64	38 1½	33 15/16	176 615/16	65 2,559	M20 ¾	88065	56905	UK313+H2313 UK313+HA2313 UK313+HE2313 UK313+HS2313	P313	10,8	
UKP315+H2315 UKP315+HA2315 UKP315+HE2315	65 27/16 2½	100 315/16	380 1431/32	290 1113/32	100 315/16	27 11/16	40 19/18	35 13/8	198 725/32	73 2,874	M22 7/8	107350	73340	UK315+H2315 UK315+HA2315 UK315+HE2315	P315	14,9	
UKP316+H2316 UKP316+HA2316 UKP316+HE2316	70 211/16 2¾	106 411/64	400 15¾	300 1113/16	110 411/32	27 11/16	40 19/16	40 19/16	210 89/32	78 3,071	M22 7/8	116850	82365	UK316+H2316 UK316+HA2316 UK316+HE2316	P316	18,6	
UKP317+H2317 UKP317+HA2317 UKP317+HS2317	75 215/16 3	112 411/64	420 1617/32	320 1219/32	110 411/32	33 15/16	45 125/32	40 19/16	220 821/32	82 3,228	M27 1	126350	91960	UK317+H2317 UK317+HA2317 UK317+HS2317	P317	20,2	
UKP318+H2318 UKP318+HA2318	80 33/16	118 441/64	430 1615/16	330 13	110 411/32	33 15/16	45 125/32	45 125/32	235 9¼	86 3,386	M27 1	135850	101650	UK318+H2318 UK318+HA2318	P318	22,8	
UKP319+H2319 UKP319+HA2319	85 35/16	125 459/64	470 18½	360 143/16	120 423/32	36 113/32	50 131/32	45 125/32	250 927/32	90 3,543	M30 11/8	145350	113050	UK319+H2319 UK319+HA2319	P319	29,3	
UKP320+H2320 UKP320+HA2320	90 37/16	140 533/64	490 199/32	380 1431/32	120 423/32	36 113/32	50 131/32	50 131/32	275 1053/64	97 3,814	M30 11/8	164350	133950	UK320+H2320 UK320+HA2320	P320	34,8	
UKP322+H2322 UKP322+HA2322	100 315/16	150 529/32	520 2015/32	400 15¾	140 5½	40 19/16	55 25/32	55 25/32	300 1113/16	105 4,134	M33 1¼	194750	171000	UK322+H2322 UK322+HA2322	P322	43,9	
UKP324+H2324 UKP324+HA2324	110 43/16	160 619/64	570 227/16	450 1723/32	140 5½	40 19/16	55 25/32	65 121/32	320 1219/32	112 4,410	M33 1¼	196650	175750	UK324+H2324 UK324+HA2324	P324	55,7	
UKP326+H2326 UKP326+HA2326	115 47/16	180 73/32	600 235/8	480 1829/32	140 5½	40 19/16	55 25/32	75 261/64	335 1331/32	121 4,764	M33 1¼	217550	203300	UK326+H2326 UK326+HA2326	P326	71,9	
UKP328+H2328 UKP328+HA2328	125 415/16	200 77/8	620 2413/32	500 1911/16	140 5½	40 19/16	55 25/32	75 261/64	390 1532/64	131 5,158	M33 1¼	240350	233700	UK328+H2328 UK328+HA2328	P328	92,5	

Bussole HA; HE; HS con filettatura in pollici
Inch dimension adapter sleeves HA; HE; HS

UKPX Serie media - Medium duty

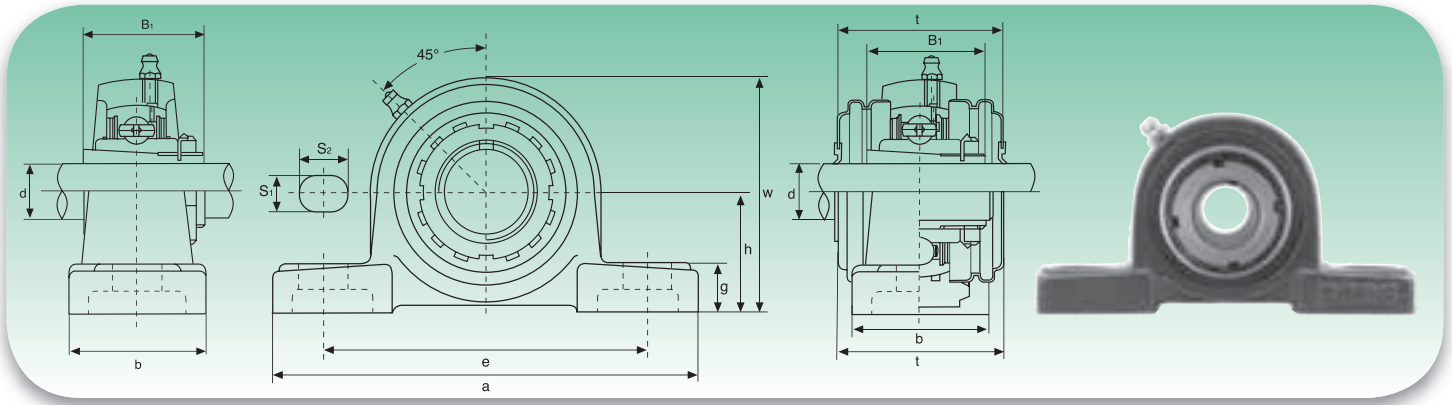

Tipo Type	Dimensioni - Dimensions										Bull. fiss. Bolt Size	Coefficients di carico (N) Load ratings (N)		Cuscinetto Bearing	Supporto Housing	Peso Weight	
	d	h	a	e	b	S ₁	S ₂	g	w	B ₁		Dinamico C Dynamic C	Statico C ₀ Static C ₀				kg
	mm/inch											mm/inch					
UKPX05+H2305	20	44,4	159	119	51	17	20	18	85	35	M14	18525	10735	UKX05+H2305	PX05	1,5	
UKPX05+HE2305	¾	1¾	6¼	411/16	2	43/64	25/32	311/32	1,378	½	½						
UKPX06+H2306	25	47,6	175	127	57	17	20	20	93	38	M14	24415	14630	UKX06+H2306	PX06	2,1	
UKPX06+HS2306	7/8	17/8	67/8	5	2¼	43/64	25/32	25/32	321/32	1,496	½						
UKPX06+HE2306	1																
UKPX07+H2307	30	54,0	203	144	57	17	20	21	105	43	M14	27645	16910	UKX07+H2307	PX07	2,7	
UKPX07+HS2307	11/8	21/8	8	521/32	2¼	43/64	25/32	13/16	41/8	1,693	½						
UKPX08+H2308	35	58,7	222	156	67	20	23	26	111	46	M16	32395	20235	UKX08+H2308	PX08	3,5	
UKPX08+HE2308	1¼	25/16	8¾	65/32	25/8	25/32	29/32	11/32	43/8	1,811	5/8						
UKPX08+HS2308	13/8																
UKPX09+H2309	40	58,7	222	156	67	20	23	26	116	50	M16	33345	22135	UKX09+H2309	PX09	3,7	
UKPX09+HA2309	17/16																
UKPX09+HE2309	1½	25/16	8¾	65/32	25/8	25/32	29/32	11/32	49/18	1,969	5/8						
UKPX09+HS2309	15/8																
UKPX10+H2310	45	63,5	241	171	73	20	23	27	126	55	M16	41230	27930	UKX10+H2310	PX10	4,6	
UKPX10+HS2310	15/8																
UKPX10+HA2310	111/16	2½	9½	647/64	27/8	25/32	29/32	11/16	431/32	2,165	5/8						
UKPX10+HE2310	1¾																
UKPX11+H2311	50	69,8	260	184	79	25	28	30	137	59	M20	49780	34390	UKX11+H2311	PX11	6,2	
UKPX11+HS2311	17/8																
UKPX11+HA2311	115/16	2¾	10¼	7¼	31/8	31/32	13/32	13/16	513/32	2,323	¾						
UKPX11+HE2311	2																
UKPX12+H2312	55	76,2	286	203	83	25	28	33	151	62	M20	54340	38095	UKX12+H2312	PX12	7,5	
UKPX12+HS2312	21/8	3	11¼	8	39/32	63/64	13/32	15/16	2,441	¾	¾						
UKPX13+H2313	60	76,2	286	203	83	25	28	33	154	65	M20	59090	41895	UKX13+H2313	PX13	7,8	
UKPX13+HA2313	23/16																
UKPX13+HE2313	2¼	3	11¼	8	39/32	63/64	13/32	15/16	61/16	2,559	¾						
UKPX13+HS2313	23/8																
UKPX15+H2315	65	88,9	330	229	89	27	30	35	175	73	M22	69065	50350	UKX15+H2315	PX15	10,5	
UKPX15+HA2315	27/16	3½	13	91/32	3½	11/16	13/16	13/8	67/8	2,874	7/8						
UKPX15+HS2315	2½																
UKPX16+H2316	70	101,6	381	283	102	27	30	40	194	78	M22	79800	58805	UKX16+H2316	PX16	15,4	
UKPX16+HA2316	211/16	4	15	115/32	41/32	11/16	13/16	19/16	75/8	3,071	7/8						
UKPX16+HS2316	2¾																
UKPX17+H2317	75	101,6	381	283	102	27	30	40	200	82	M22	91295	67925	UKX17+H2317	PX17	15,8	
UKPX17+HA2317	215/16	4	15	115/32	41/32	11/16	13/16	19/16	77/8	3,228	7/8						
UKPX17+HE2317	3																
UKPX18+H2318	80	101,6	381	283	111	27	30	40	206	86	M22	103550	77805	UKX18+H2318	PX18	18,6	
UKPX18+HA2318	33/16	4	15	115/32	43/8	11/16	13/16	19/16	81/8	3,386	7/8						
UKPX20+H2320	90	127	432	337	121	33	36	45	244	97	M27	126350	99750	UKX20+H2320	PX20	29,3	
UKPX20+HA2320	3½	5	17	139/32	4¾	15/16	113/32	125/32	95/8	3,814	11/16						

Bussole HA; HE; HS con filettatura in pollici
Inch dimension adapter sleeves HA; HE; HS

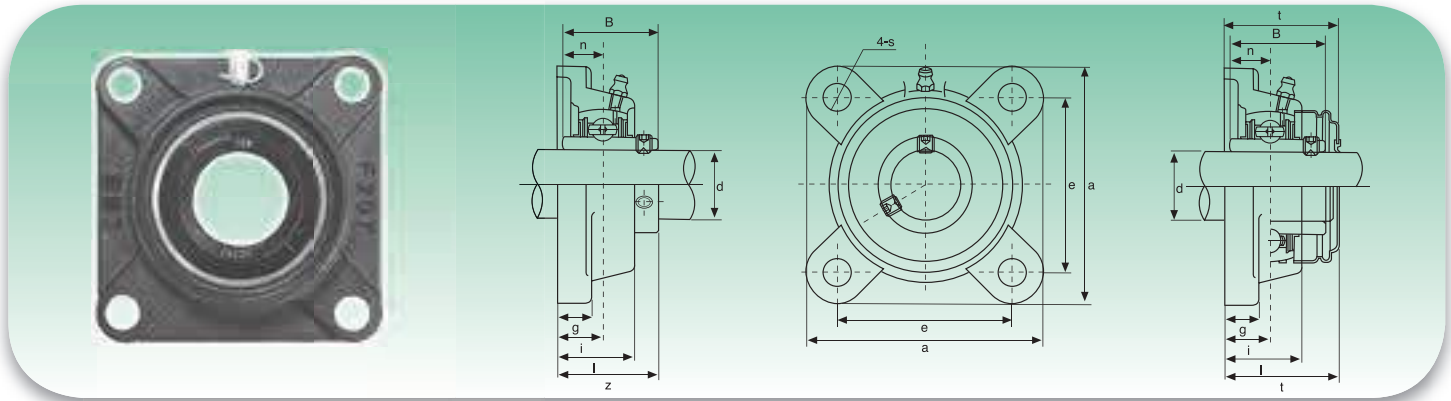
UCF2 Serie normale - Standard duty

Tipo Type	Dimensioni - Dimensions											Bull. fiss. Bolt Size	Coefficients di carico (N) Load ratings (N)		Cuscinetto Bearing	Supporto Housing	Peso Weight	
	d	a	e	i	g	l	s	z	t	B	n		Dinamico C Dynamic C	Statico C ₀ Static C ₀				kg
	mm/inch												mm/inch					
UCF201 UCF201-8	12 ½	86 33/8	64 233/64	15 19/32	12 15/32	25,5 1	12 15/32	33,3 15/16	37,5 131/64	31 1,2205	12,7 0,500	M10 3/8	12160	6318	UC201 UC201-8	F204	0,60 0,59	
UCF202 UCF202-9 UCF202-10	15 9/16 5/8	86 33/8	64 233/64	15 19/32	12 15/32	25,5 1	12 15/32	33,3 15/16	37,5 131/64	31 1,2205	12,7 0,500	M10 3/8	12160	6318	UC202 UC202-9 UC202-10	F204	0,59 0,59 0,59	
UCF203 UCF203-11	17 11/16	86 33/8	64 233/64	15 19/32	12 15/32	25,5 1	12 15/32	33,3 15/16	37,5 131/64	31 1,2205	12,7 0,500	M10 3/8	12160	6318	UC203 UC203-11	F204	0,58 0,57	
UCF204 UCF204-12	20 ¾	86 33/8	64 233/64	15 19/32	12 15/32	25,5 1	12 15/32	33,3 15/16	37,5 131/64	31 1,2205	12,7 0,500	M10 3/8	12160	6318	UC204 UC204-12	F204	0,56 0,56	
UCF205 UCF205-13 UCF205-14 UCF205-15 UCF205-16	25 13/16 7/8 15/16 1	95 3¾	70 2¾	16 5/8	14 35/64	27 11/16	12 15/32	35,8 113/32	40 19/16	34,1 1,3425	14,3 0,563	M10 3/8	13300	7457	UC205 UC205-13 UC205-14 UC205-15 UC205-16	F205	0,80 0,84 0,83 0,81 0,80	
UCF206 UCF206-17 UCF206-18 UCF206-19 UCF206-20	30 11/16 11/8 13/15 1¼	108 4¼	83 317/64	18 45/64	14 35/64	31 17/32	12 15/32	40,2 119/32	44,5 1¾	38,1 1,5000	15,9 0,626	M10 3/8	18525	10735	UC206 UC206-17 UC206-18 UC206-19 UC206-20	F206	1,12 1,15 1,14 1,12 1,11	
UCF207 UCF207-20 UCF207-21 UCF207-22 UCF207-23	35 1¼ 15/16 13/8 17/16	117 439/64	92 35/8	19 ¾	16 5/8	34 111/32	14 35/64	44,4 1¾	48,5 129/32	42,9 1,6890	17,5 0,689	M12 7/16	24415	14630	UC207 UC207-20 UC207-21 UC207-22 UC207-23	F207	1,46 1,52 1,49 1,46 1,43	
UCF208 UCF208-24 UCF208-25	40 1½ 19/16	130 51/8	102 41/64	21 53/64	16 5/8	36 127/64	16 5/8	51,2 21/64	55,5 23/16	49,2 1,9370	19 0,748	M14 ½	27645	16910	UC208 UC208-24 UC208-25	F208	1,84 1,88 1,85	
UCF209 UCF209-26 UCF209-27 UCF209-28	45 15/8 111/16 1¾	137 513/32	105 49/64	22 55/64	18 23/32	38 1½	16 5/8	52,2 21/16	56,5 27/32	49,2 1,9370	19 0,748	M14 ½	32395	20235	UC209 UC209-26 UC209-27 UC209-28	F209	2,15 2,25 2,21 2,17	
UCF210 UCF210-29 UCF210-30 UCF210-31 UCF210-32	50 113/16 17/8 115/16 2	143 55/8	111 43/8	22 55/64	18 23/32	40 19/16	16 5/8	54,6 25/32	59,5 211/32	51,6 2,0315	19 0,748	M14 ½	33345	22135	UC210 UC210-29 UC210-30 UC210-31 UC210-32	F210	2,42 2,54 2,49 2,44 2,40	
UCF211 UCF211-32 UCF211-33 UCF211-34 UCF211-35	55 2 21/16 21/8 23/16	162 63/8	130 51/8	25 63/64	20 25/32	43 111/16	19 ¾	58,4 15/16	63 231/64	55,6 2,1890	22,2 0,874	M16 5/8	41230	27930	UC211 UC211-32 UC211-33 UC211-34 UC211-35	F211	3,31 3,46 3,40 3,35 3,29	
UCF212 UCF212-36 UCF212-37 UCF212-38 UCF212-39	60 2¼ 25/16 23/8 27/16	175 657/64	143 55/8	29 19/64	20 25/32	48 157/64	19 ¾	68,7 245/64	73,5 257/64	65,1 2,5630	25,4 1,000	M16 5/8	49780	34390	UC212 UC212-36 UC212-37 UC212-38 UC212-39	F212	4,28 4,41 4,33 4,26 4,19	
UCF213 UCF213-40 UCF213-41	65 2½ 29/16	187 723/64	149 555/64	30 13/16	22 55/64	50 131/32	19 ¾	69,7 2¾	74,5 215/16	65,1 2,5630	25,4 1,000	M16 5/8	54340	38095	UC213 UC213-40 UC213-41	F213	4,99 5,08 4,99	
UCF214 UCF214-42 UCF214-43 UCF214-44	70 25/8 211/16 2¾	193 719/32	152 563/64	31 17/32	22 55/64	54 21/8	19 ¾	75,4 221/32	81,5 313/64	74,6 2,9370	30,2 1,189	M16 5/8	59090	41895	UC214 UC214-42 UC214-43 UC214-44	F214	5,85 6,06 5,96 5,86	
UCF215 UCF215-45 UCF215-46 UCF215-47 UCF215-48	75 213/16 27/8 215/16 3	200 77/8	159 617/64	34 111/32	22 55/64	56 27/32	19 ¾	78,5 33/32	83,5 39/32	77,8 3,0630	33,3 1,311	M16 5/8	64030	45885	UC215 UC215-45 UC215-46 UC215-47 UC215-48	F215	6,91 7,16 7,05 6,94 6,82	
UCF216 UCF216-49 UCF216-50 UCF216-51	80 31/16 31/8 33/16	208 83/16	165 6½	34 111/32	22 55/64	58 29/32	23 29/32	83,3 39/32	88,5 339/64	82,6 3,2520	33,3 1,311	M20 ¾	69065	50350	UC216 UC216-49 UC216-50 UC216-51	F216	7,50 7,68 7,55 7,42	
UCF217 UCF217-52 UCF217-53 UCF217-55	85 ¾ 35/6 37/16	220 821/33	175 657/64	36 127/64	24 15/16	63 215/32	23 29/32	87,6 37/16	92,6 341/64	85,7 3,3740	34,1 1,343	M20 ¾	79800	58805	UC217 UC217-52 UC217-53 UC217-55	F217	9,66 9,88 9,74 9,45	
UCF218 UCF218-56	90 3½	235 9¼	187 723/64	40 137/64	24 15/16	68 211/16	23 29/32	96,3 325/32	101,5 4	96 3,7795	39,7 1,5630	M20 ¾	91295	67925	UC218 UC218-56	F218	12,06 12,17	
UCF220 UCF220-64	100 101,6	265 265	210 210	44 44	25 25	70 70	27 27	110 110	138 138	108 108	42 42	M12 M12	122,1	93	UC220 UC220-64	F218	17,58 17,58	

Disponibile in acciaio inox Supporto: AISI 304 - Cuscinetto: AISI 440C o 420C - Available stainless steel Housing: AISI 304 - Bearing: AISI 440C or 420C
Disponibile su richiesta con cuscinetto SA (SAF.) - Available under request with SA bearing (SAF.)

HCF2 Serie normale - Standard duty

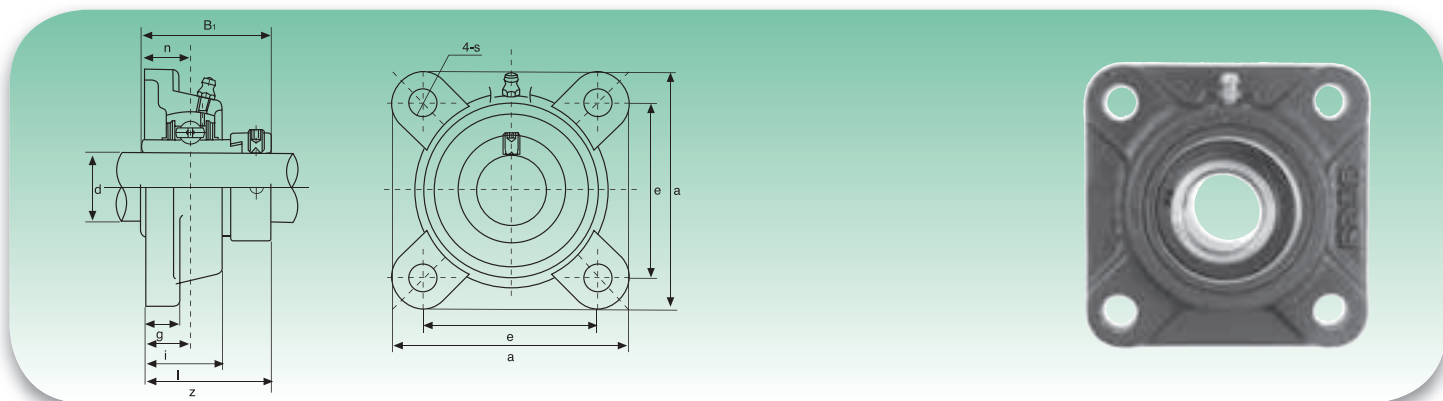

Tipo Type	Dimensioni - Dimensions										Bull. fiss. Bolt Size	Coefficienti di carico (N) Load ratings (N)		Cuscinetto Bearing	Supporto Housing	Peso Weight
	d	a	e	i	g	l	s	z	B ₁	n		Dinamico C Dynamic C	Statico C ₀ Static C ₀			
	mm/inch											mm/inch				
HCF204	20	86	64	15	12	25,5	12	41,6	43,7	17,1	M10	12160	6318	HC204	F204	0,63
HCF204-12	¾	33/8	233/64	19/32	15/32	1	15/32	141/64	1,720	0,673	3/8			HC204-12		0,63
HCF205	25	95	70	16	14	27	12	42,9	44,4	17,5	M10			HC205		0,87
HCF205-13	13/16													HC205-13		0,92
HCF205-14	7/8	3¾	2¾	5/8	35/64	11/16	15/32	111/16	1,748	0,689	3/8	13300	7457	HC205-14	F205	0,91
HCF205-15	15/16													HC205-15		0,89
HCF205-16	1													HC205-16		0,87
HCF206	30	108	83	18	14	31	12	48,1	48,4	18,3	M10			HC206		1,25
HCF206-17	11/16													HC206-17		1,30
HCF206-18	11/8	4¼	317/64	45/64	35/64	17/32	15/32	157/64	1,906	0,720	3/8	18525	10735	HC206-18	F206	1,27
HCF206-19	13/16													HC206-19		1,25
HCF206-20	1¼													HC206-20		1,24
HCF207	35	117	92	19	16	34	14	51,3	51,1	18,8	M12			HC207		1,58
HCF207-20	1¼													HC207-20		1,65
HCF207-21	15/16	439/64	35/8	¾	5/8	111/32	35/64	21/64	2,012	0,740	7/16	24415	14630	HC207-21	F207	1,61
HCF207-22	13/8													HC207-22		1,58
HCF207-23	17/16													HC207-23		1,55
HCF208	40	130	102	21	16	36	16	55,9	56,3	21,4	M14			HC208		1,99
HCF208-24	1½	51/8	41/64	53/64	5/8	127/32	5/8	213/64	2,217	0,843	½	27645	16910	HC208-24	F208	2,04
HCF208-25	19/16													HC208-25		2,00
HCF209	45	137	105	22	18	38	16	56,9	56,3	21,4	M14			HCF209		2,32
HCF209-26	15/8													HC209-26		2,43
HCF209-27	111/16	513/32	49/64	55/64	55/64	1½	5/8	215/64	2,217	0,843	½	32395	20235	HC209-27	F209	2,38
HCF209-28	1¾													HC209-28		2,34
HCF210	50	143	111	22	18	40	16	60,1	62,7	24,6	M14			HCF210		2,61
HCF210-29	113/16													HC210-29		2,76
HCF210-30	17/8	55/8	43/8	55/64	55/64	19/16	5/8	23/8	2,469	0,969	½	33345	22135	HC210-30	F210	2,70
HCF210-31	115/16													HC210-31		2,64
HCF210-32	2													HC210-32		2,58
HCF211	55	162	130	25	20	43	19	68,6	71,4	27,8	M16			HCF211		3,52
HCF211-32	2													HC211-32		3,72
HCF211-33	22/16	63/8	51/8	63/64	25/32	111/16	¾	245/64	2,811	1,094	5/8	41230	27930	HC211-33	F211	3,64
HCF211-34	21/8													HC211-34		3,57
HCF211-35	23/16													HC211-35		3,49
HCF212	60	175	143	29	20	48	19	75,8	77,8	31	M16			HC212		4,62
HCF212-36	2¼													HC212-36		4,78
HCF212-37	25/16	657/64	55/8	19/64	25/32	157/64	¾	263/64	3,063	1,220	5/8	49780	34390	HC212-37	F212	4,69
HCF212-38	23/8													HC212-38		4,64
HCF212-39	27/16													HC212-39		4,51
HCF213	65	187	149	30	22	50	19	81,6	85,7	34,1	M16			HC213		5,55
HCF213-40	2½	723/64	555/64	13/16	55/64	131/32	¾	37/32	3,374	1,343	5/8	54340	38095	HC213-40	F213	5,65
HCF213-41	29/16													HC213-41		5,54
HCF214	70	193	152	31	22	54	19	82,6	85,7	34,1	M16			HC214		6,35
HCF214-42	23/8													HC214-42		6,59
HCF214-43	211/16	719/32	563/64	17/32	55/64	21/8	¾	3¼	3,374	1,343	5/8	59090	41895	HC214-43	F214	6,48
HCF214-44	2¾													HC214-44		6,36
HCF215	75	200	159	34	22	56	19	88,8	92,1	37,3	M16			HC215		7,54
HCF215-45	213/16													HC215-45		7,84
HCF215-46	27/8	77/8	617/64	111/32	55/64	27/32	¾	3½	3,626	1,426	5/8	64030	45885	HC215-46	F215	7,71
HCF215-47	215/16													HC215-47		7,58
HCF215-48	3													HC215-48		7,44

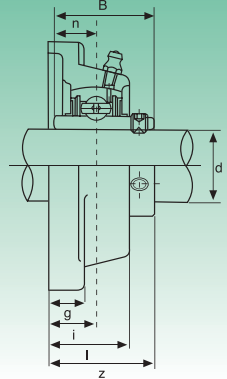
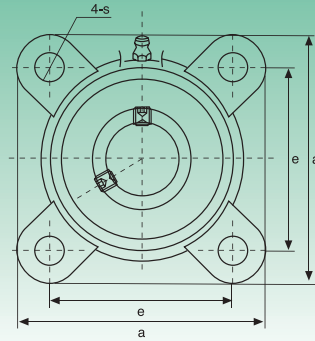

Tipo Type	Dimensioni - Dimensions										Bull. fiss. Bolt Size	Coefficients di carico (N) Load ratings (N)		Cuscinetto Bearing	Supporto Housing	Peso Weight kg								
	d	a	e	i	g	l	s	z	B	n		Dinamico C Dynamic C	Statico C ₀ Static C ₀											
	mm/inch											mm/inch												
UCF305 UCF305-13 UCF305-14 UCF305-15 UCF305-16	25 13/16 7/8 15/16 1	110	80	16	13	29	16	39	38	15	M14	20140	10355	UC305 UC305-13 UC305-14 UC305-15 UC305-16	F305	1,1								
UCF306 UCF306-17 UCF306-18 UCF306-19	30 11/16 11/8 13/16	125	95	18	15	32	16	44	43	17	M14			25365			14250	UC306 UC306-17 UC306-18 UC306-19	F306	1,6				
UCF307 UCF307-20 UCF307-21 UCF307-22 UCF307-23	35 1 1/4 15/16 13/8 17/16	135	100	20	16	36	19	49	48	19	M16							31730			18335	UC307 UC307-20 UC307-21 UC307-22 UC307-23	F307	2
UCF308 UCF308-24 UCF308-25	40 1 1/2 19/6	150	112	23	17	40	19	56	52	19	M16											38665		
UCF309 UCF309-26 UCF309-27 UCF309-28	45 15/8 111/16 1 3/4	160	125	25	18	44	19	60	57	22	M16			46455			28025		UC309 UC309-26 UC309-27 UC309-28	F309				
UCF310 UCF310-29 UCF310-30 UCF310-31	50 113/16 17/8 115/16	175	132	28	19	48	23	67	61	22	M20	58900	36385		UC310 UC310-29 UC310-30 UC310-31	F310			4,5					
UCF311 UCF311-32 UCF311-33 UCF311-34 UCF311-35	55 2 21/16 21/8 23/16	185	140	30	20	52	23	71	66	25	M20				68020			42750			UC311 UC311-32 UC311-33 UC311-34 UC311-35	F311	5,5	
UCF312 UCF312-36 UCF312-37 UCF312-38 UCF312-39	60 2 1/4 25/16 23/8 27/16	195	150	33	22	56	23	78	71	26	M20			77805			49590			UC312 UC312-36 UC312-37 UC312-38 UC312-39	F312			6,5
UCF313 UCF313-40 UCF313-41	65 2 1/2 29/16	208	166	33	22	58	23	78	75	30	M20									88065				
UCF314 UCF314-42 UCF314-43 UCF314-44	70 25/8 211/16 2 3/4	226	178	36	25	61	25	81	78	33	M22	98800	64790		UC314 UC314-42 UC314-43 UC314-44	F314		9,5						
UCF315 UCF315-45 UCF315-46 UCF315-47 UCF315-48	75 213/16 27/8 215/16 3	236	184	39	25	66	25	89	82	32	M22				107350				73340	UC315 UC315-45 UC315-46 UC315-47 UC315-48		F315	12	
UCF316 UCF316-49 UCF316-50 UCF316-51	80 31/16 31/8 33/16	250	196	38	27	68	31	90	86	34	M27			116850			82365			UC316 UC316-49 UC316-50 UC316-51	F316			14
UCF317 UCF317-52 UCF317-53 UCF317-55	85 3 3/4 35/16 37/16	260	204	44	27	74	31	100	96	40	M27	126350	91960			UC317 UC317-52 UC317-53 UC317-55		F317		16				
UCF318 UCF318-55 UCF318-56	90 37/16 3 1/2	280	216	44	30	76	35	100	96	40	M30					135850								
UCF319 UCF319-58 UCF319-59 UCF319-60	95 35/8 311/16 3 3/4	290	228	59	30	94	35	121	103	41	M30			145350	113050		UC319 UC319-58 UC319-59 UC319-60		F319		22			
UCF320 UCF320-61 UCF320-62 UCF320-63 UCF320-64	100 313/16 37/8 315/16 4	310	242	59	32	94	38	125	108	42	M33					164350	133950					UC320 UC320-61 UC320-62 UC320-63 UC320-64	F320	25
UCF321	105	310	242	59	32	94	38	127	-	44	M33	174800	145350					UC321		F321		25,6		
UCF322	110	340	266	60	35	96	41	131	-	46	M36	194750	171000	UC322	F322			34,7						
UCF324	120	370	290	65	40	110	41	140	-	51	M36	196650	175750	UC324	F324			47,2						
UCF326	130	410	320	65	45	115	41	146	-	54	M36	217550	203300	UC326	F326	62,7								
UCF328	140	450	350	75	55	125	41	161	-	59	M36	240350	233700	UC328	F328	87,0								

UCFS3 Serie pesante - Heavy duty

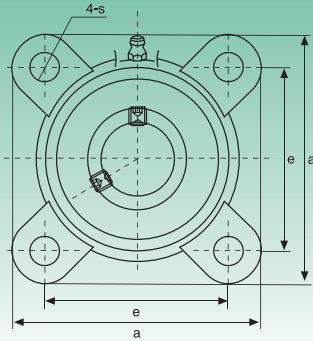
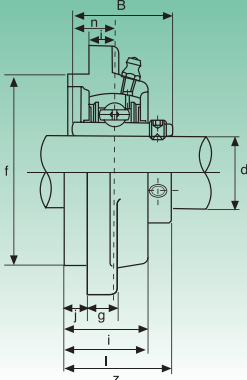

Tipo Type	Dimensioni - Dimensions												Bull. fiss. Bolt Size	Coefficienti di carico (N) Load ratings (N)		Cuscinetto Bearing	Supporto Housing	Peso Weight	
	d	a	e	i	s	j	g	l	f	z	B	n		Dinamico C Dynamic C	Statico C ₀ Static C ₀				kg
	mm/inch													mm/inch					
UCFS305 UCFS305-13 UCFS305-14 UCFS305-15 UCFS305-16	25 13/16 7/8 15/16 1	110	80	9	16	7	13	29	80	39	38	15	M14 1/2	20140	10355	UC305 UC305-13 UC305-14 UC305-15 UC305-16	FS305	1,3	
UCFS306 UCFS306-17 UCFS306-18 UCFS306-19	30 11/16 11/8 13/16	125	95	10	16	8	15	32	90	44	43	17	M14 1/2	25365	14250	UC306 UC306-17 UC306-18 UC306-19	FS306	1,9	
UCFS307 UCFS307-20 UCFS307-21 UCFS307-22 UCFS307-23	35 1 1/4 15/16 13/8 17/16	135	100	11	19	9	16	36	100	49	48	19	M16 5/8	31730	18335	UC307 UC307-20 UC307-21 UC307-22 UC307-23	FS307	2,4	
UCFS308 UCFS308-24 UCFS308-25	40 1 1/2 19/16	150	112	13	19	10	17	40	115	56	52	19	M16 5/8	38665	22800	UC308 UC308-24 UC308-25	FS308	3,3	
UCFS309 UCFS309-26 UCFS309-27 UCFS309-28	45 15/8 111/16 1 3/4	160	125	14	19	11	18	44	125	60	57	22	M16 5/8	46455	28020	UC309 UC309-26 UC309-27 UC309-28	FS309	4,0	
UCFS310 UCFS310-29 UCFS310-30 UCFS310-31	50 113/16 17/8 115/16	175	132	16	23	12	19	48	140	67	61	22	M20 3/4	58900	36385	UC310 UC310-29 UC310-30 UC310-31	FS310	5,3	
UCFS311 UCFS311-32 UCFS311-33 UCFS311-34 UCFS311-35	55 2 21/16 21/8 23/16	185	140	17	23	13	20	52	150	71	66	26	M20 3/4	68020	42750	UC311 UC311-32 UC311-33 UC311-34 UC311-35	FS311	6,2	
UCFS312 UCFS312-36 UCFS312-37 UCFS312-38 UCFS312-39	60 2 1/4 25/16 23/8 27/16	195	150	19	23	14	22	56	160	78	71	25	M20 3/4	77805	49590	UC312 UC312-36 UC312-37 UC312-38 UC312-39	FS312	7,2	
UCFS313 UCFS313-40 UCFS313-41	65 2 1/2 29/16	208	166	15	23	18	22	58	175	78	75	30	M20 3/4	88065	56905	UC313 UC313-40 UC313-41	FS313	8,9	
UCFS314 UCFS314-42 UCFS314-43 UCFS314-44	70 25/8 211/16 2 3/4	223	178	18	25	18	25	61	185	81	78	33	M20 3/4	98800	64790	UC314 UC314-42 UC314-43 UC314-44	FS314	11	
UCFS315 UCFS315-45 UCFS315-46 UCFS315-47 UCFS315-48	75 213/16 27/8 215/16 3	236	184	21	25	18	25	66	200	89	82	32	M22 7/8	107350	73340	UC315 UC315-45 UC315-46 UC315-47 UC315-48	FS315	13	
UCFS316 UCFS316-49 UCFS316-50 UCFS316-51	80 31/16 31/8 33/16	250	196	18	31	20	27	68	210	90	86	34	M27 1	116850	82365	UC316 UC316-49 UC316-50 UC316-51	FS316	15	
UCFS317 UCFS317-52 UCFS317-53 UCFS317-55	85 3 1/4 35/16 37/16	260	204	24	31	20	27	74	220	100	96	40	M27 1	126350	91960	UC317 UC317-52 UC317-53 UC317-55	FS317	17	
UCFS318 UCFS318-55 UCFS318-56	90 37/16 3 1/2	280	216	24	35	20	30	76	240	100	96	40	M30 1 1/8	135850	101650	UC318 UC318-55 UC318-56	FS318	21	
UCFS319 UCFS319-58 UCFS319-59 UCFS319-60	95 35/8 311/16 3 3/4	280	228	39	35	20	30	94	250	121	103	41	M30 1 1/8	145350	113050	UC319 UC319-58 UC319-59 UC319-60	FS319	25	
UCFS320 UCFS320-61 UCFS320-62 UCFS320-63 UCFS320-64	100 313/16 37/8 315/16 4	310	242	39	38	20	32	94	260	125	108	42	M33 1 1/4	164350	133950	UC320 UC320-61 UC320-62 UC320-63 UC320-64	FS320	30	

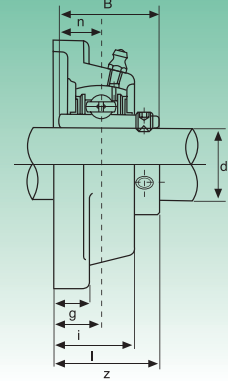
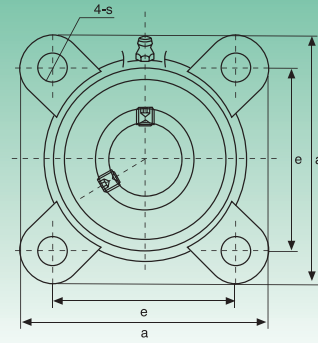

Tipo Type	Dimensioni - Dimensions										Bull. fiss. Bolt Size	Coefficienti di carico (N) Load ratings (N)		Cuscinetto Bearing	Supporto Housing	Peso Weight kg
	d	a	e	i	g	l	s	z	B	n		Dinamico C Dynamic C	Statico C ₀ Static C ₀			
	mm/inch											mm/inch				
UCFX05 UCFX05-13 UCFX05-14 UCFX05-15 UCFX05-16	25 13/16 7/8 15/16 1	108	83	18	13	30	12	40,2	38,1	15,9	M10			UCX05 UCX05-13 UCX05-14 UCX05-15 UCX05-16	FX05	1,0
UCFX06 UCFX06-17 UCFX06-18 UCFX06-19 UCFX06-20	30 11/16 11/8 13/16 1 1/4	117	92	19	14	34	16	44,4	42,9	17,5	M14			UCX06 UCX06-17 UCX06-18 UCX06-19 UCX06-20	FX06	1,7
UCFX07 UCFX07-21 UCFX07-22 UCFX07-23	35 15/16 13/8 17/16	130	102	21	14	38	16	51,2	49,2	19	M14			UCX07 UCX07-21 UCX07-22 UCX07-23	FX07	2,1
UCFX08 UCFX08-24 UCFX08-25	40 1 1/2 19/16	137	105	22	14	40	19	52,2	49,2	19	M16			UCX08 UCX08-24 UCX08-25	FX08	2,4
UCFX09 UCFX09-26 UCFX09-27 UCFX09-28 UCFX09-29	45 15/8 111/16 1 3/4 113/16	143	111	23	14	40	19	55,6	51,6	19	M16			UCX09 UCX09-26 UCX09-27 UCX09-28 UCX09-29	FX09	2,5
UCFX10 UCFX10-30 UCFX10-31 UCFX10-32	50 17/8 115/16 2	162	130	26	20	44	19	59,4	55,6	22,2	M16			UCX10 UCX10-30 UCX10-31 UCX10-32	FX10	3,9
UCFX11 UCFX11-33 UCFX11-34 UCFX11-35 UCFX11-36 UCFX11-37	55 21/16 21/8 23/16 2 1/4 25/16	175	143	29	20	49	19	68,7	65,1	25,4	M16			UCX11 UCX11-33 UCX11-34 UCX11-35 UCX11-36 UCX11-37	FX11	4,9
UCFX12 UCFX12-38 UCFX12-39	60 23/8 27/16	187	149	34	21	59	19	73,7	65,1	25,4	M16			UCX12 UCX12-38 UCX12-39	FX12	5,2
UCFX13 UCFX13-40 UCFX13-41	65 2 1/2 29/16	187	149	34	21	59	19	78,4	74,6	30,2	M16			UCX13 UCX13-40 UCX13-41	FX13	5,3
UCFX14 UCFX14-42 UCFX14-43 UCFX14-44	70 25/8 211/16 2 3/4	197	152	37	24	60	23	81,5	77,8	33,3	M20			UCX14 UCX14-42 UCX14-43 UCX14-44	FX14	7,3
UCFX15 UCFX15-45 UCFX15-46 UCFX15-47 UCFX15-48	75 213/16 27/8 215/16 3	197	152	40	24	68	23	89,3	82,6	33,3	M20			UCX15 UCX15-45 UCX15-46 UCX15-47 UCX15-48	FX15	8,1
UCFX16 UCFX16-49 UCFX16-50 UCFX16-51 UCFX16-52	80 31/16 31/8 33/16 3 3/4	214	171	40	24	70	23	91,6	85,7	34,1	M20			UCX16 UCX16-49 UCX16-50 UCX16-51 UCX16-52	FX16	9,9
UCFX17 UCFX17-53 UCFX17-55	85 35/16 37/16	214	171	40	24	70	23	93,3	96	39,7	M20			UCX17 UCX17-53 UCX17-55	FX17	11
UCFX18 UCFX18-56 UCFX18-57	90 37/16 3 1/2	214	171	45	24	76	23	106,1	104	42,9	M20			UCX18 UCX18-56 UCX18-57	FX18	11
UCFX20 UCFX20-58 UCFX20-59 UCFX20-60 UCFX20-61	100 313/16 37/8 315/16 4	268	211	59	31	97	31	127,3	117,5	49,2	M27			UCX20 UCX20-58 UCX20-59 UCX20-60 UCX20-61	FX20	17

UKF2 Serie normale - Standard duty

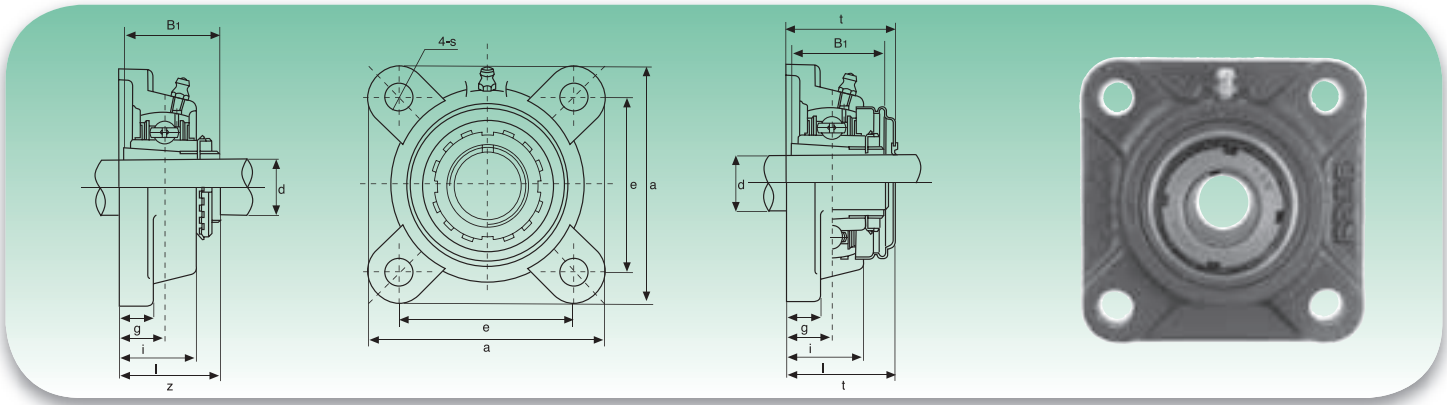

Tipo Type	Dimensioni - Dimensions										Bull. fiss. Bolt Size	Coefficienti di carico (N) Load ratings (N)		Cuscinetto Bearing	Supporto Housing	Peso Weight
	d	a	e	i	g	l	s	z	t	B ₁		Dinamico C Dynamic C	Statico C ₀ Static C ₀			
	mm/inch											mm/inch				
UKF205+H2305	20	95	70	16	14	27	12	35,5	40	35	M10			UK205+H2305	F205	0,85
UKF205+HE2305	¾	3¾	2¾	5/8	35/64	11/16	15/32	125/64	19/16	1,378	3/8	13300	7457	UK205+HE2305		
UKF206+H2306	25	108	83	18	14	31	12	39	44,5	38	M10			UK206+H2306	F206	1,16
UKF206+HS2306	7/8											18525	10735	UK206+HS2306		
UKF206+HE2306	1	4¼	317/64	45/64	35/64	17/32	15/32	117/32	1¾	1,496	3/8			UK206+HE2306		
UKF207+H2307	30	117	92	19	16	34	14	42,5	48,5	43	M12			UK207+H2307	F207	1,55
UKF207+HS2307	11/8	439/64	35/8	¾	5/8	111/32	35/64	143/64	129/32	1,693	7/16	24415	14630	UK207+HS2307		
UKF208+H2308	35	130	102	21	16	36	16	46,5	55,5	46	M14			UK208+H2308	F208	1,94
UKF208+HE2308	1¼											27645	16910	UK208+HE2308		
UKF208+HS2308	13/8	51/8	41/64	53/64	5/8	127/64	5/8	153/64	23/16	1,811	½			UK208+HS2308		
UKF209+H2309	40	137	105	22	18	38	16	48,5	56,5	50	M14			UK209+H2309	F209	2,30
UKF209+HA2309	17/16											32395	20235	UK209+HA2309		
UKF209+HE2309	1½	513/32	49/64	55/64	23/32	1½	5/8	129/32	27/32	1,969	½			UK209+HE2309		
UKF209+HS2309	15/8													UK209+HS2309		
UKF210+H2310	45	143	111	22	18	40	16	50	59,5	55	M14			UK210+H2310	F210	2,59
UKF210+HS2310	15/8											33345	22135	UK210+HS2310		
UKF210+HA2310	111/16	55/8	43/8	55/64	23/32	19/16	5/8	131/32	211/32	2,165	½			UK210+HA2310		
UKF210+HE2310	1¾													UK210+HE2310		
UKF211+H2311	50	162	130	25	20	43	19	54,5	63	59	M16			UK211+H2311	F211	3,46
UKF211+HS2311	17/8											41230	27930	UK211+HS2311		
UKF211+HA2311	115/16	63/8	51/8	63/64	25/32	111/16	¾	29/64	231/64	2,323	5/8			UK211+HA2311		
UKF211+HE2311	2													UK211+HE2311		
UKF212+H2312	55	175	143	29	20	48	19	61	73,5	62	M16			UK212+H2312	F212	4,33
UKF212+HS2312	21/8	657/64	55/8	19/64	25/32	157/64	¾	219/32	257/64	2,441	5/8	49780	34390	UK212+HS2312		
UKF213+H2313	60	187	149	30	22	50	19	64	74,5	65	M16			UK213+H2313	F213	4,90
UKF213+HA2313	23/16											54340	38095	UK213+HA2313		
UKF213+HE2313	2¼	723/64	555/64	13/16	55/64	131/32	¾	233/64	215/16	2,559	5/8			UK213+HE2313		
UKF213+HS2313	23/8													UK213+HS2313		
UKF215+H2315	65	200	159	34	22	56	19	71	83,5	73	M16			UK215+H2315	F215	7,02
UKF215+HA2315	27/16											64030	45885	UK215+HA2315		
UKF215+HE2315	2½	77/8	617/64	111/32	55/64	27/32	¾	251/64	39/32	2,874	5/8			UK215+HE2315		
UKF216+H2316	70	208	165	34	22	58	23	73,5	88,5	78	M20			UK216+H2316	F216	7,76
UKF216+HA2316	211/16											69065	50350	UK216+HA2316		
UKF216+HE2316	2¾	83/16	6½	111/32	55/64	29/32	29/32	257/64	331/64	3,071	¾			UK216+HE2316		
UKF217+H2317	75	220	175	36	24	63	23	77	92,6	82	M20			UK217+H2317	F217	10,08
UKF217+HA2317	215/16											79800	58805	UK217+HA2317		
UKF217+HE2317	3	821/32	657/64	127/64	15/16	215/32	29/32	31/32	341/64	3,228	¾			UK217+HE2317		
UKF218+H2318	80	235	187	40	24	68	23	81,5	101,5	86	M20			UK218+H2318	F218	12,44
UKF218+HA2318	33/16	9¼	723/64	137/64	15/16	211/16	29/32	313/64	4	3,386	¾	91295	67925	UK218+HA2318		

Bussole HA; HE; HS con filettatura in pollici
Inch dimension adapter sleeves HA; HE; HS

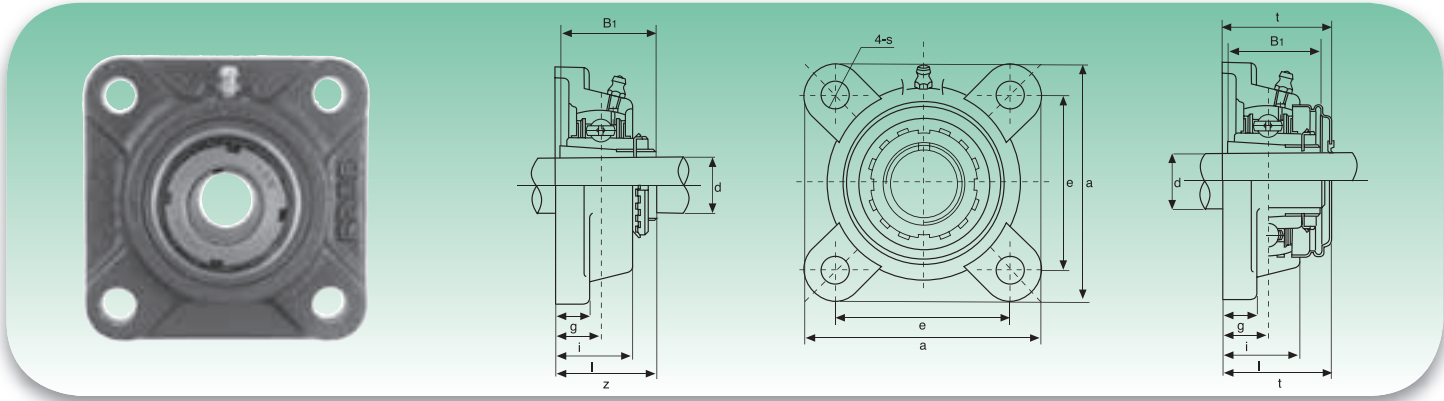
UKF3 Serie pesante - Heavy duty

Tipo Type	Dimensioni - Dimensions									Bull. fiss. Bolt Size	Coefficients di carico (N) Load ratings (N)		Cuscinetto Bearing	Supporto Housing	Peso Weight	
	d	a	e	i	g	l	s	z	B ₁		Dinamico C Dynamic C	Statico C ₀ Static C ₀				kg
	mm/inch										mm/inch					
UKF305+H2305 UKF305+HE2305	20 ¾	110 411/32	80 35/32	16 5/8	13 ½	29 15/32	16 5/8	37 129/64	35 1,378	M14 ½	20140	10355	UK305+H2305 UK305+HE2305	F305	1,4	
UKF306+H2306 UKF306+HS2306 UKF306+HE2306	25 7/8 1	125 429/32	95 347/64	18 45/64	15 19/32	32 1¼	16 5/8	40,5 219/32	38 1,496	M14 ½	25365	14250	UK306+H2306 UK306+HS2306 UK306+HE2306	F306	1,9	
UKF307+H2307 UKF307+HS2307	30 11/8	135 55/16	100 315/16	20 25/32	16 5/8	36 113/32	19 ¾	44,5 2¾	43 1,693	M16 5/8	31730	18335	UK307+H2307 UK307+HS2307	F307	2,3	
UKF308+H2308 UKF308+HE2308 UKF308+HS2308	35 1¼ 13/8	150 529/32	112 413/32	23 29/32	17 21/32	40 19/16	19 ¾	50 231/32	46 1,811	M16 5/8	38665	22800	UK308+H2308 UK308+HE2308 UK308+HS2308	F308	3,1	
UKF309+H2309 UKF309+HA2309 UKF309+HE2309 UKF309+HS2309	40 17/16 1½ 15/8	160 61/16	125 459/64	25 63/64	18 23/32	44 123/32	19 ¾	54,5 29/64	50 1,969	M16 5/8	46455	28025	UK309+H2309 UK309+HA2309 UK309+HE2309 UK309+HS2309	F309	4,1	
UKF310+H2310 UKF310+HS2310 UKF310+HA2310 UKF310+HE2310	45 15/8 111/16 1¾	175 67/8	132 513/64	28 17/64	19 ¾	48 17/8	23 29/32	60 223/64	55 2,165	M20 ¾	58900	36385	UK310+H2310 UK310+HS2310 UK310+HA2310 UK310+HE2310	F310	5,1	
UKF311+H2311 UKF311+HS2311 UKF311+HA2311 UKF311+HE2311	50 17/8 115/16 2	185 79/32	140 533/64	30 13/16	20 25/32	52 21/16	23 29/32	63,5 2½	59 2,323	M20 ¾	68020	42750	UK311+H2311 UK311+HS2311 UK311+HA2311 UK311+HE2311	F311	5,9	
UKF312+H2312 UKF312+HS2312	55 21/8	195 711/16	150 529/32	33 119/64	22 7/8	56 27/32	23 29/32	69 223/32	62 2,441	M20 ¾	77805	49590	UK312+H2312 UK312+HS2312	F312	6,8	
UKF313+H2313 UKF313+HA2313 UKF313+HE2313 UKF313+HS2313	60 23/16 2¼ 23/8	208 83/16	166 617/32	33 119/64	22 7/8	58 29/32	23 29/32	71 251/64	65 2,559	M20 ¾	88065	56905	UK313+H2313 UK313+HA2313 UK313+HE2313 UK313+HS2313	F313	7,9	
UKF315+H2315 UKF315+HA2315 UKF315+HE2315	65 27/16 2½	236 99/32	184 7¼	39 117/32	25 63/64	66 219/32	25 63/64	81 33/16	73 2,874	M22 7/8	107350	73340	UK315+H2315 UK315+HA2315 UK315+HE2315	F315	11,7	
UKF316+H2316 UKF316+HA2316 UKF316+HE2316	70 211/16 2¾	250 927/32	196 723/32	38 1½	27 11/16	68 211/16	31 17/32	83,5 39/32	78 3,071	M27 1	116850	82365	UK316+H2316 UK316+HA2316 UK316+HE2316	F316	12,9	
UKF317+H2317 UKF317+HA2317 UKF317+HS2317	75 215/16 3	260 10¼	204 81/32	44 147/64	27 11/16	74 229/32	31 35/8	92 35/8	82 3,228	M27 1	126350	91960	UK317+H2317 UK317+HA2317 UK317+HS2317	F317	15,2	
UKF318+H2318 UKF318+HA2318	80 33/16	280 111/32	216 8½	44 147/64	30 13/16	76 3	35 13/8	93,5 311/16	86 3,386	M30 11/8	135850	101650	UK318+H2318 UK318+HA2318	F318	19	
UKF319+H2319 UKF319+HA2319	85 35/16	290 1113/32	228 831/32	59 221/64	30 13/16	94 311/16	35 13/8	111 43/8	90 3,543	M30 11/8	145350	113050	UK319+H2319 UK319+HA2319	F319	21,9	
UKF320+H2320 UKF320+HA2320	90 37/16	310 127/32	242 917/32	59 221/64	32 1¼	94 311/16	38 1½	115 417/32	97 3,814	M33 1¼	164350	133950	UK320+H2320 UK320+HA2320	F320	25,4	
UKF322+H2322 UKF322+HA2322	100 315/16	340 133/8	266 1015/32	60 323/64	35 13/8	96 325/32	41 139/64	121 449/64	105 4,134	M36 13/8	194750	171000	UK322+H2322 UK322+HA2322	F322	35,2	
UKF324+H2324 UKF324+HA2324	110 43/16	370 165/32	290 1219/32	65 29/16	40 19/16	110 411/32	41 139/64	130 51/8	112 4,410	M36 13/8	196650	175750	UK324+H2324 UK324+HA2324	F324	47,6	
UKF326+H2326 UKF326+HA2326	115 47/16	410 165/32	320 1219/32	65 29/6	45 125/32	115 417/32	41 139/64	134 59/32	121 4,764	M36 13/8	217550	203300	UK326+H2326 UK326+HA2326	F326	65,3	
UKF328+H2328 UKF328+HA2328	125 415/16	450 1723/32	350 1325/32	75 261/64	55 25/32	125 429/32	41 139/64	148 553/64	131 5,158	M36 13/8	240350	233700	UK328+H2328 UK328+HA2328	F328	93,4	

Bussole HA; HE; HS con filettatura in pollici
Inch dimension adapter sleeves HA; HE; HS

UKFX Serie media - Medium duty

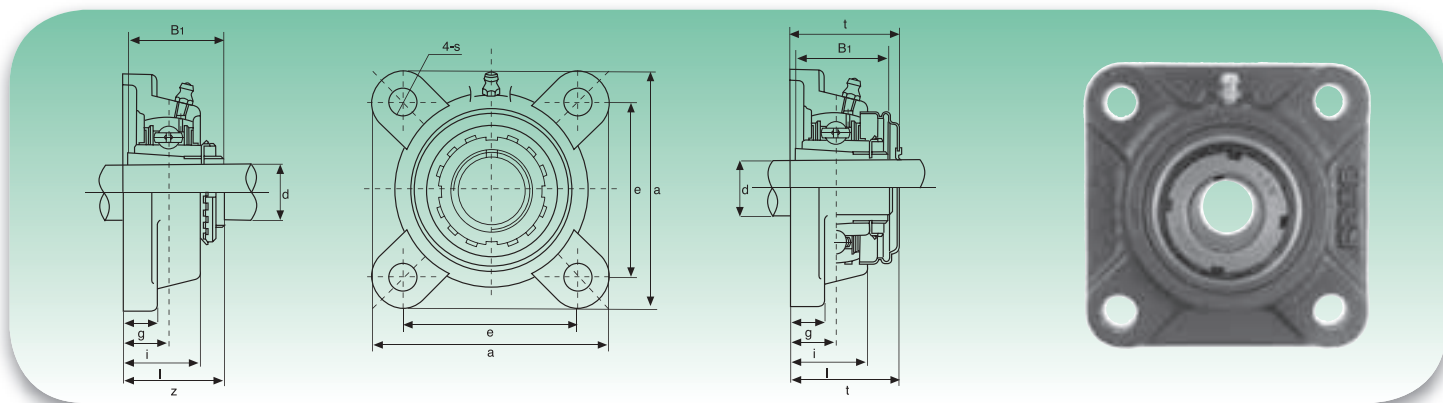

Tipo Type	Dimensioni - Dimensions									Bull. fiss. Bolt Size	Coefficienti di carico (N) Load ratings (N)		Cuscinetto Bearing	Supporto Housing	Peso Weight kg
	d	a	e	i	g	l	s	z	B ₁		Dinamico C Dynamic C	Statico C ₀ Static C ₀			
	mm/inch										mm/inch				
UKFX05+H2305	20	108	83	18	13	30	12	39	35	M10	18525	10735	UKX05+H2305	FX05	1,2
UKFX05+HE2305	¾	4¼	317/64	45/64	½	13/16	15/32	117/32	1,378	3/8			UKX05+HE2305		
UKFX06+H2306	25	117	92	19	14	34	16	41,5	38	M14	24415	14630	UKX06+H2306	FX06	1,6
UKFX06+HS2306	7/8												UKX06+HS2306		
UKFX06+HE2306	1	439/64	35/8	¾	9/16	111/32	5/8	141/64	1,496	½			UKX06+HE2306		
UKFX07+H2307	30	130	102	21	14	38	16	45,5	43	M14	27645	16910	UKX07+H2307	FX07	2,0
UKFX07+HS2307	11/8	51/8	41/64	53/64	9/16	1½	5/8	151/64	1,693	½			UKX07+HS2307		
UKFX08+H2308	35	137	105	22	14	40	19	47,5	46	M16	32395	20235	UKX08+H2308	FX08	2,3
UKFX08+HE2308	1¼												UKX08+HE2308		
UKFX08+HS2308	13/8	513/32	49/64	55/64	9/16	19/16	¾	17/8	1,811	5/8			UKX08+HS2308		
UKFX09+H2309	40	143	111	23	14	40	19	50	50	M16	33345	22135	UKX09+H2309	FX09	2,7
UKFX09+HA2309	15/8												UKX09+HA2309		
UKFX09+HE2309	1½	55/8	43/8	29/32	9/16	19/16	¾	131/32	1,969	5/8			UKX09+HE2309		
UKFX09+HS2309	15/8												UKX09+HS2309		
UKFX10+H2310	45	162	130	26	20	44	19	55,5	55	M16	41230	27930	UKX10+H2310	FX10	3,6
UKFX10+HS2310	15/8												UKX10+HS2310		
UKFX10+HA2310	111/16	63/8	51/8	11/32	25/32	123/32	¾	23/16	2,165	5/8			UKX10+HA2310		
UKFX10+HE2310	1¾												UKX10+HE2310		
UKFX11+H2311	50	175	143	29	20	49	19	60	59	M16	49780	34390	UKX11+H2311	FX11	4,6
UKFX11+HS2311	17/8												UKX11+HS2311		
UKFX11+HA2311	115/16	657/64	55/8	19/64	25/32	115/16	¾	223/64	2,323	5/8			UKX11+HA2311		
UKFX11+HE2311	2												UKX11+HE2311		
UKFX12+H2312	55	187	149	34	21	59	19	67	62	M16	54340	38095	UKX12+H2312	FX12	5,5
UKFX12+HS2312	21/8	723/64	555/64	111/32	13/16	25/16	¾	241/64	2,441	5/8			UKX12+HS2312		
UKFX13+H2313	60	187	149	34	21	59	19	68	65	M16	59090	41895	UKX13+H2313	FX13	6,0
UKFX13+HA2313	23/16												UKX13+HA2313		
UKFX13+HE2313	2¼	723/64	555/64	111/32	13/16	25/16	¾	211/16	2,559	5/8			UKX13+HE2313		
UKFX13+HS2313	23/8												UKX13+HS2313		
UKFX15+H2315	65	197	152	40	24	68	23	77,5	73	M20	69065	50350	UKX15+H2315	FX15	8,1
UKFX15+HA2315	27/16												UKX15+HA2315		
UKFX15+HS2315	2½	7¾	563/64	137/64	15/16	211/16	29/32	23/64	2,874	¾			UKX15+HS2315		
UKFX16+H2316	70	214	171	40	24	70	23	80	78	M20	79800	58805	UKX16+H2316	FX16	9,5
UKFX16+HA2316	211/16												UKX16+HA2316		
UKFX16+HS2316	2¾	87/16	647/64	137/64	15/16	2¾	29/32	35/32	3,071	¾			UKX16+HS2316		
UKFX17+H2317	75	214	171	40	24	70	23	81,5	82	M20	91295	67925	UKX17+H2317	FX17	10,4
UKFX17+HA2317	215/16												UKX17+HA2317		
UKFX17+HE2317	3	87/16	647/64	137/64	15/16	2¾	29/32	3,228	3¾	¾			UKX17+HE2317		
UKFX18+H2318	80	214	171	45	24	76	23	88	86	M20	103550	77805	UKX18+H2318	FX18	11,4
UKFX18+HA2318	33/16	87/16	647/64	149/64	15/16	3	29/32	315/32	3,386	¾			UKX18+HA2318		
UKFX20+H2320	90	268	211	59	31	97	31	106	97	M27	126350	99750	UKX20+H2320	FX20	18,4
UKFX20+HA2330	3½	109/16	85/16	221/64	17/32	313/13	17/32	43/64	3,814	1			UKX20+HA2330		

Bussole HA; HE; HS con filettatura in pollici
Inch dimension adapter sleeves HA; HE; HS

UCFC2 Serie normale - Standard duty

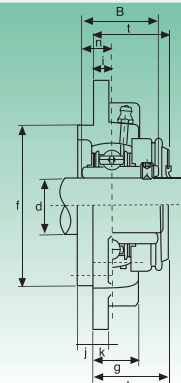
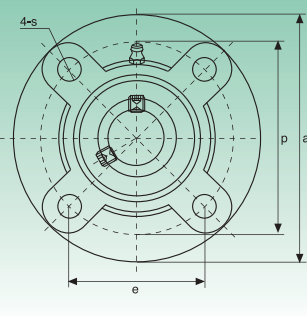
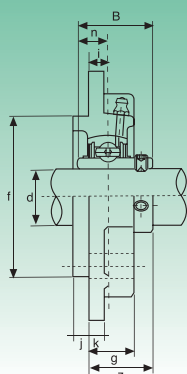

Tipo Type	Dimensioni - Dimensions													Bull. fiss. Bolt Size	Coefficienti di carico (N) Load ratings (N)		Cuscinetto Bearing	Supporto Housing	Peso Weight																	
	d	a	p	e	i	s	j	k	g	f	z	t	B		n	Dinamico C				Statico C ₀	kg															
																mm/inch													Dynamic C	Static C ₀						
UCFC201	12	100	78	55,1	10	12	5	7	20,5	62	28,3	32,5	31	12,7	M10	12160	6318	UC201	FC204	0,73																
UCFC201-8	1/2	315/16	35/64	211/64	25/64	15/32	13/64	9/32	13/16	2,4409	11/8	19/32	1,2205	0,500	3/8			0,72																		
UCFC202	15	100	78	55,1	10	12	5	7	20,5	62	28,3	32,5	31	12,7	M10	12160	6318	UC202	FC204	0,72																
UCFC202-9	9/16	315/16	35/64	211/64	25/64	15/32	13/64	9/32	13/16	2,4409	11/8	19/32	1,2205	0,500	3/8			0,72																		
UCFC202-10	5/8	315/16	35/64	211/64	25/64	15/32	13/64	9/32	13/16	2,4409	11/8	19/32	1,2205	0,500	3/8	0,72																				
UCFC203	17	100	78	55,1	10	12	5	7	20,5	62	28,3	32,5	31	12,7	M10	12160	6318	UC203	FC204	0,71																
UCFC203-11	11/16	315/16	35/64	211/64	25/64	15/32	13/64	9/32	13/16	2,4409	11/8	19/32	1,2205	0,500	3/8			0,70																		
UCFC204	20	100	78	55,1	10	12	5	7	20,5	62	28,3	32,5	31	12,7	M10	12160	6318	UC204	FC204	0,69																
UCFC204-12	3/4	315/16	35/64	211/64	25/64	15/32	13/64	9/32	13/16	2,4409	11/8	19/32	1,2205	0,500	3/8			0,69																		
UCFC205	25	115	90	63,6	10	12	6	7	21	70	29,8	34	34,1	14,3	M10	13300	7457	UC205	FC205	1,00																
UCFC205-13	13/16	417/32	335/64	2 1/2	25/64	15/32	15/64	9/32	53/64	2,7559	111/64	111/32	1,3425	0,563	3/8			1,04																		
UCFC205-14	7/8																	1,03																		
UCFC205-15	15/16																	1,01																		
UCFC205-16	1																	1,00																		
UCFC206	30															125	100	70,7	10	12	8	8	23	80	32,2	36,5	38,1	15,9	M10	18525	10735	UC206	FC206	1,30		
UCFC206-17	11/16	459/64	315/16	17	225/32	25/64	15/32	5/16	5/16	29/32	3,1496	117/64	17/16	1,5000	0,626	3/8	1,31																			
UCFC206-18	11/8																1,32																			
UCFC206-19	13/16																1,30																			
UCFC206-20	1 1/4																1,29																			
UCFC207	35																135	110	77,8	11	14	8	9	26	90	36,4	41	42,9	17,5	M12	24415	14630	UC207	FC207	1,81	
UCFC207-20	1 1/4	55/16	421/64	31/16	7/16	35/64	5/16	23/64	11/32	3,5433	17/16	15/8	1,6890	0,689	7/16	1,87																				
UCFC207-21	15/16																1,84																			
UCFC207-22	13/8																1,81																			
UCFC207-23	17/16																1,78																			
UCFC208	40																145	120	84,8	11	14	10	9	26	100	41,2	45,5	49,2	19	M12	27645	16910	UC208	FC208	2,14	
UCFC208-24	1 1/2	545/64	423/32	311/32	7/16	35/64	25/64	23/84	11/32	3,9370	15/8	151/64	1,9370	0,748	7/16	2,18																				
UCFC208-25	19/6																2,15																			
UCFC209	45																160	132	93,3	10	16	12	14	26	105	40,2	44,5	49,2	19	M14	32395	20235	UC209	FC209	2,68	
UCFC209-26	15/8	111/66	619/64	513/64	343/64	25/64	5/8	15/32	35/64	11/32	4,1339	137/64	1 3/4	1,9370	0,748	1/2	2,78																			
UCFC209-27	11/8																	2,74																		
UCFC209-28	1 3/4																	2,70																		
UCFC210	50																	165	138	97,6	10	16	12	14	28	110	42,6	47,5	51,6	19			M14		33345	22135
UCFC210-29	113/16																	6 1/2	57/16	327/32	25/64	5/8	15/32	35/64	17/64	4,3307	11/16	17/8	2,0315	0,748	1/2	3,02				
UCFC210-30	17/8	2,97																																		
UCFC210-31	115/16	2,92																																		
UCFC210-32	2	2,88																																		
UCFC211	55	185	150	106,1	13	19	12	15	31	125	46,4	51	55,6	22,2	M16	41230	27930																UC211	FC211	4,01	
UCFC211-32	2	79/32	529/32	43/16	33/64	3/4	15/32	19/32	17/32	4,9213	153/64	21/64	2,1890	0,874	5/8			4,16																		
UCFC211-33	21/16																		4,10																	
UCFC211-34	21/8																		4,05																	
UCFC211-35	23/16																		3,99																	
UCFC212	60															195	160		113,1	17	19	12	15	36	135	56,7	61,5	65,1	25,4	M16	49780	34390	UC212	FC212	4,94	
UCFC212-36	2 1/4	711/166	619/64	4429/64	43/64	3/4	15/32	19/32	127/64	5,3150	215/64	227/64	2,5630	1,000	5/8	5,07																				
UCFC212-37	25/16																4,99																			
UCFC212-38	23/8																4,92																			
UCFC212-39	27/16																4,85																			
UCFC213	65																205	170	120,2	16	19	14	15	36	145	55,7	60,5	65,1	25,4	M16	54340	38095	UC213	FC213	5,65	
UCFC213-40	2 1/2	85/64	611/164	447/64	5/8	3/4	35/64	19/32	127/64	5,5118	13/16	225/64	2,5630	1,000	5/8	5,74																				
UCFC213-41	29/16																5,65																			
UCFC214	70																215	177	125,1	17	19	14	18	40	150	61,4	-	74,6	30,2	M16	59090	41895	UC214	FC214	6,95	
UCFC214-42	25/8	211/68	1815/32	6321/32	459/64	43/64	3/4	35/64	23/32	137/64	5,9055	113/32	-	2,9370	1,189	5/8	7,16																			
UCFC214-43	2 5/8																	7,06																		
UCFC214-44	2 3/4																	6,96																		
UCFC215	75																	220	184	130,1	18	19	16	18	40	160	62,5	-	77,8	33,3			M16		64030	45885
UCFC215-45	213/16																	831/32	7 1/4	51/8	23/32	3/4	5/8	23/32	137/64	6,2992	215/32	-	3,0630	1,311	5/8	7,81				
UCFC215-46	27/8	7,70																																		
UCFC215-47	215/16	7,59																																		
UCFC215-48	3	7,47																																		
UCFC216	80	240	200	141,4	18	23	16	18	42	170	67,3	-	82,6	33,3	M20	69065	50350																UC216	FC216	9,15	
UCFC216-49	31/16	929/64	77/8	59/16	23/32	29/32	5/8	23/32	121/32	6,6929	221/32	-	3,2520	1,311	3/4			9,28																		
UCFC216-50	31/8																		9,20																	
UCFC216-51	33/16																		9,07																	
UCFC217	85																		250	208	147,1	18	23	18	20	45	180	69,6	-	85,7	34,1	M20	79800		58805	UC217
UCFC217-52	3 3/4															35/16	927/32		83/16	551/64	23/32	29/32	23/32	25/32	125/32	7,0866	2 3/4	-	3,3740	1,343	3/4	11,03				
UCFC217-53	3 1/2	10,89																																		
UCFC217-55	37/16	10,60																																		
UCFC218	90	265	220	155,5	22	23	18	20	50	190	78,3	-	96	39,7	M20			91295															67925	UC218	FC218	12,96
UCFC218-56	3 1/2	107/16	821/32	61/8	55/64	29/32	23/32	25/32	131/32	7,4803	33/32	-	3,7795	1,5630	3/4	13,07																				

Disponibile in acciaio inox Supporto: AISI 304 - Cuscinetto: AISI 440C o 420C - Available stainless steel Housing: AISI 304 - Bearing: AISI 440C or 420C
Disponibile su richiesta con cuscinetto SA (SAFC...) - Available under request with SA bearing (SAFC...)

HCFC2 Serie normale - Standard duty

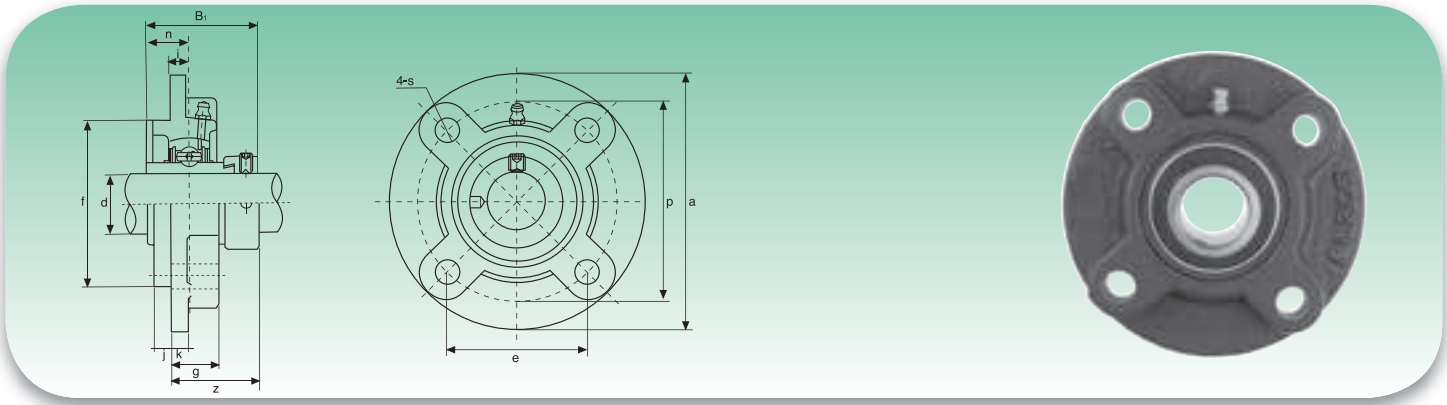

Tipo Type	Dimensioni - Dimensions													Bull. fiss. Bolt Size	Coefficients di carico (N) Load ratings (N)		Cuscinetto Bearing	Supporto Housing	Peso Weight
	d	a	p	e	i	s	j	k	g	f	z	B ₁	n		Dinamico C Dynamic C	Statico C ₀ Static C ₀			
	mm/inch														mm/inch				
HCFC204	12	100	78	55,1	10	12	5	7	20,5	62	36,6	43,7	17,1	M10	12160	6318	HC204	FC204	0,76
HCFC204-12	¾	315/16	35/64	211/64	25/64	15/32	13/64	9/32	13/16	2,4409	17/16	1,720	0,673	3/8			0,76		
HCFC205	25	115	90	63,6	10	12	6	7	21	70	36,9	44,4	17,5	M10	13300	7457	HC205	FC205	1,07
HCFC205-13	13/16																1,12		
HCFC205-14	7/8	417/32	335/64	2½	25/64	15/32	15/64	9/32	53/64	2,7559	129/64	1,748	0,689	3/8			1,11		
HCFC205-15	15/16																1,09		
HCFC205-16	1																1,07		
HCFC206	30	125	100	70,7	10	12	8	8	23	80	40,1	48,4	18,3	M10	18525	10735	HC206	FC206	1,43
HCFC206-17	11/16																1,48		
HCFC206-18	11/8	459/64	315/16	225/32	25/64	15/32	5/16	5/16	29/32	3,1496	137/64	1,906	0,720	3/8			1,45		
HCFC206-19	13/16																1,43		
HCFC206-20	1¼																1,40		
HCFC207	35	135	110	77,8	11	14	8	9	26	90	43,3	51,1	18,8	M12	24415	14630	HC207	FC207	1,93
HCFC207-20	1¼																2,00		
HCFC207-21	15/16	15/16	421/64	31/16	7/16	35/64	5/16	23/64	11/32	3,5433	145/64	2,012	0,740	7/16			1,96		
HCFC207-22	13/8																1,93		
HCFC207-23	17/16																1,87		
HCFC208	40	145	120	84,8	11	14	10	9	26	100	45,9	56,3	21,4	M12	27645	16910	HC208	FC208	2,29
HCFC208-24	1½	545/64	423/32	311/32	7/16	35/64	25/64	23/64	11/32	3,9370	113/16	2,217	0,843	7/16			2,34		
HCFC208-25	19/16																2,30		
HCFC209	45	160	132	93,3	10	16	12	14	26	105	44,9	56,3	21,4	M14	32395	20235	HCF209	FC209	2,85
HCFC209-26	15/8																2,96		
HCFC209-27	111/16	6619/64	513/64	343/64	25/64	5/8	15/32	35/64	11/32	4,1339	149/64	2,217	0,843	½			2,91		
HCFC209-28	1¾																2,87		
HCFC210	50	165	138	97,6	10	16	12	14	28	110	48,1	62,7	24,6	M14	33345	22135	HCF210	FC210	3,09
HCFC210-29	113/16																3,24		
HCFC210-30	17/8	6½	57/16	327/32	25/64	5/8	15/32	35/94	17/64	4,3307	157/64	2,469	0,969	½			3,18		
HCFC210-31	115/16																3,12		
HCFC210-32	2														3,06				
HCFC211	55	185	150	106,1	13	19	12	15	31	125	56,6	71,4	27,8	M16	41230	27930	HCF211	FC211	4,22
HCFC211-32	2																4,42		
HCFC211-33	22/16	79/32	529/32	43/16	33/64	¾	15/32	19/32	17/32	4,9213	215/64	2,811	1,094	5/8			4,34		
HCFC211-34	21/8																4,27		
HCFC211-35	23/16																4,19		
HCFC212	60	195	160	113,1	17	19	12	15	36	135	63,8	77,8	31	M16	49780	34390	HC212	FC212	5,28
HCFC212-36	2¼																5,44		
HCFC212-37	25/16	711/16	619/64	429/64	43/64	¾	15/32	19/32	127/64	5,3150	233/64	3,063	1,220	5/8			5,35		
HCFC212-38	23/8																5,30		
HCFC212-39	27/16																5,17		
HCFC213	65	205	170	120,2	16	19	14	15	36	145	67,6	85,7	34,1	M16	54340	38095	HC213	FC213	6,21
HCFC213-40	2½	85/64	611/16	447/64	5/8	¾	35/64	19/32	127/64	5,5118	221/32	3,374	1,343	5/8			6,31		
HCFC213-41	29/16																6,20		
HCFC214	70	215	177	125,1	17	19	14	18	40	150	68,6	85,7	34,1	M16	59090	41895	HC214	FC214	7,45
HCFC214-42	23/8																7,69		
HCFC214-43	211/16	815/32	631/32	459/64	43/64	¾	35/64	23/32	137/64	5,9055	245/64	3,374	1,343	5/8			7,58		
HCFC214-44	2¾																7,46		
HCFC215	75	220	184	130,1	18	19	16	18	40	160	72,8	92,1	37,3	M16	64030	45885	HC215	FC215	8,19
HCFC215-45	213/16																8,49		
HCFC215-46	27/8	821/32	7¼	51/8	23/32	¾	5/8	23/32	137/64	6,2992	27/8	3,626	1,469	5/8			8,36		
HCFC215-47	215/16																8,23		
HCFC215-48	3																8,09		

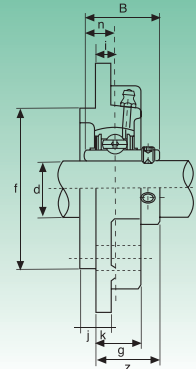
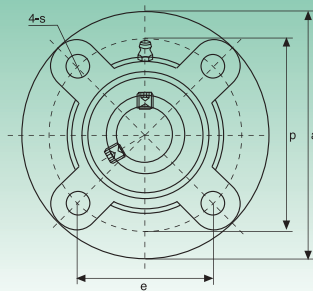
UCFCX Serie media - Medium duty

Tipo Type	Dimensioni - Dimensions													Bull. fiss. Bolt Size	Coefficients di carico (N) Load ratings (N)		Cuscinetto Bearing	Supporto Housing	Peso Weight												
	d	a	p	e	i	s	j	k	g	f	z	B	n		Dinamico C Dynamic C	Statico C ₀ Static C ₀				kg											
	mm/inch														mm/inch																
UCFCX05 UCFCX05-13 UCFCX05-14 UCFCX05-15 UCFCX05-16	25 13/16 7/8 15/16 1	111	92	65	10	9,5	6	9,5	24	76	32,2	38,1	15,9	M8	18525	10735	UCX05 UCX05-13 UCX05-14 UCX05-15 UCX05-16	FCX05	1,2												
UCFCX06 UCFCX06-17 UCFCX06-18 UCFCX06-19 UCFCX06-20	30 11/16 11/8 13/16 1 1/4	127	105	74,2	8	12	9,5	9,5	22,5	85	33,4	42,9	17,5	M10			24415			14630	UCX06 UCX06-17 UCX06-18 UCX06-19 UCX06-20	FCX06	1,5								
UCFCX07 UCFCX07-21 UCFCX07-22 UCFCX07-23	35 15/16 13/8 17/16	133	111	78,5	9	12	11	11	26	92	39,2	49,2	19	M10							27645			16910	UCX07 UCX07-21 UCX07-22 UCX07-23	FCX07	1,9				
UCFCX08 UCFCX08-24 UCFCX08-25	40 1 1/2 19/16	133	111	78,5	9	12	11	11	26	92	39,2	49,2	19	M10											32395			20235	UCX08 UCX08-24 UCX08-25	FCX08	2,0
UCFCX09 UCFCX09-26 UCFCX09-27 UCFCX09-28 UCFCX09-29	45 15/8 111/16 1 3/4 113/16	155	130	91,9	8	14	12	11	25	108	40,6	51,6	19	M12															33345		
UCFCX10 UCFCX10-30 UCFCX10-31 UCFCX10-32	50 17/8 115/16 2	162	136	96,2	7	14	16	11	25	118	40,4	55,6	22,2	M12	41230	27930		UCX10 UCX10-30 UCX10-31 UCX10-32	FCX10												
UCFCX11 UCFCX11-33 UCFCX11-34 UCFCX11-35 UCFCX11-36 UCFCX11-37	55 21/16 21/8 23/16 2 1/4 25/16	180	152	107,5	4	16	22	13	26	127	43,7	65,1	25,4	M14			49780	34390		UCX11 UCX11-33 UCX11-34 UCX11-35 UCX11-36 UCX11-37		FCX11	4,3								
UCFCX12 UCFCX12-38 UCFCX12-39	60 23/8 27/16	194	165	116,7	11	16	20	14	33	140	50,7	65,1	25,4	M14						54340	38095			UCX12 UCX12-38 UCX12-39		FCX12	5,3				
UCFCX13 UCFCX13-40 UCFCX13-41	65 2 1/2 29/16	194	165	116,7	11	16	20	14	33	140	55,4	74,6	30,2	M14										59090	41895			UCX13 UCX13-40 UCX13-41		FCX13	5,7
UCFCX14 UCFCX14-42 UCFCX14-43 UCFCX14-44	70 25/8 21/16 2 3/4	222	190	134,3	14	19	20	14	36	164	58,5	77,8	33,3	M16														64030	45885		
UCFCX15 UCFCX15-45 UCFCX15-46 UCFCX15-47 UCFCX15-48	75 213/16 27/8 215/16 3	222	190	134,3	12	19	22	16	35	164	61,3	82,6	33,3	M16	69065	50350			UCX15 UCX15-45 UCX15-46 UCX15-47 UCX15-48												
UCFCX16 UCFCX16-49 UCFCX16-50 UCFCX16-51 UCFCX16-52	80 31/16 31/8 33/16 3 1/4	260	219	154,8	10	23	25	19	36	186	61,6	85,7	34,1	M20			79800	58805	UCX16 UCX16-49 UCX16-50 UCX16-51 UCX16-52			FCX16	11,3								
UCFCX17 UCFCX17-53 UCFCX17-55	85 35/16 37/16	260	219	154,8	10	23	25	19	36	186	66,3	96	39,7	M20					91295	67925	UCX17 UCX17-53 UCX17-55					FCX17	12,9				
UCFCX18 UCFCX18-56 UCFCX18-57	90 37/16 3 1/2	260	219	154,8	12	23	28	19	43	186	73,1	104	42,9	M20							103550			77805	UCX18 UCX18-56 UCX18-57					FCX18	12
UCFCX20 UCFCX20-58 UCFCX20-59 UCFCX20-60 UCFCX20-61	100 313/16 37/8 315/16 4	276	238	168,3	22	23	28	22	66	206	90,3	117,5	49,2	M20											126350			99750	UCX20 UCX20-58 UCX20-59 UCX20-60 UCX20-61		

UKFC2 Serie normale - Standard duty

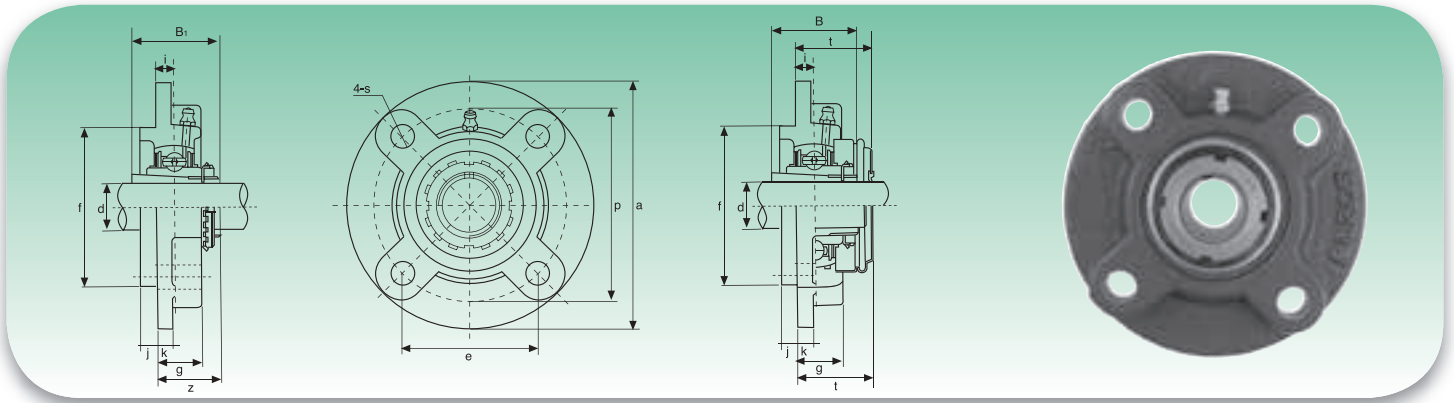

Tipo Type	Dimensioni - Dimensions														Bull. fiss. Bolt Size	Coefficients di carico (N) Load ratings (N)		Cuscinetto Bearing	Supporto Housing	Peso Weight
	d	a	p	e	i	s	j	k	g	f	z	t	B ₁	Dinamico C Dynamic C _d		Statico C ₀ Static C ₀	kg			
	mm/inch																			
UKFC205+H2305	20	115	90	63,6	10	12	6	7	21	70	29,5	34	35	M10	13300	7457	UK205+H2305	FC205	1,05	
UKFC205+HE2305	¾	417/32	335/64	2½	15/64	15/32	15/64	9/32	53/64	2,7559	15/32	111/32	1,378	3/8			UK205+HE2305			
UKFC206+H2306	25	125	100	70,7	10	12	8	8	23	80	31	36,5	38	M10	18525	10735	UK206+H2306	FC206	1,34	
UKFC206+HS2306	7/8	459/64	315/16	225/32	25/64	15/32	5/16	5/16	29/32	3,1496	17/32	17/16	1,496	3/8			UK206+HS2306			
UKFC206+HE2306	1																UK206+HE2306			
UKFC207+H2307	30	135	110	77,8	11	14	8	9	26	90	33,5	41	43	M12	24415	14630	UK207+H2307	FC207	1,90	
UKFC207+HS2307	11/8	55/6	421/64	31/16	7/16	35/64	5/16	23/64	11/32	3,5433	15/16	15/8	1,693	7/16			UK207+HS2307			
UKFC208+H2308	35	145	120	84,8	11	14	10	9	26	100	35,5	45,5	46	M12	27645	16910	UK208+H2308	FC208	2,24	
UKFC208+HE2308	1¼	545/64	423/32	311/32	7/16	35/64	25/64	23/64	11/32	3,9370	125/64	151/64	1,811	7/16			UK208+HE2308			
UKFC208+HS2308	13/8																UK208+HS2308			
UKFC209+H2309	40	160	132	93,3	10	16	12	14	26	105	36	44,5	50	M14	32395	20235	UK209+H2309	PFC209	2,83	
UKFC209+HA2309	17/16	619/64	513/64	343/64	25/64	5/8	15/32	35/64	11/32	4,1339	127/64	1¾	1,969	½			UK209+HA2309			
UKFC209+HE2309	1½																UK209+HE2309			
UKFC209+HS2309	15/8																UK209+HS2309			
UKFC210+H2310	45	165	138	97,6	10	16	12	14	28	110	37,5	47,5	55	M14	33345	22135	UK210+H2310	FC210	3,07	
UKFC210+HS2310	15/8	57/16	327/32	25/64	5/8	15/32	35/64	17/64	4,3307	115/32	17/8	2,165	½	UK210+HS2310						
UKFC210+HA2310	111/16													UK210+HA2310						
UKFC210+HE2310	1¾													UK210+HE2310						
UKFC211+H2311	50	185	150	106,1	13	19	12	15	31	125	41,5	51	59	M16	41230	27930	UK211+H2311	FC211	4,16	
UKFC211+HS2311	17/8	79/32	529/32	43/16	33/64	¾	15/32	19/32	17/32	4,9213	141/64	21/64	2,323	5/8			UK211+HS2311			
UKFC211+HA2311	115/16																UK211+HA2311			
UKFC211+HE2311	2																UK211+HE2311			
UKFC212+H2312	55	195	160	113,1	17	19	12	15	36	135	48	61,5	62	M16	49780	34390	UK212+H2312	FC212	4,99	
UKFC212+HS2312	21/8	711/16	619/64	429/64	43/64	¾	15/32	19/32	127/64	5,3150	157/64	227/64	2,441	5/8			UK212+HS2312			
UKFC213+H2313	60	205	170	120,2	16	19	14	15	36	145	49	60,5	65	M16	54340	38095	UK213+H2313	FC213	5,56	
UKFC213+HA2313	23/16	85/64	611/16	447/64	5/8	¾	35/64	19/32	127/64	5,5118	115/16	225/64	2,559	5/8			UK213+HA2313			
UKFC213+HE2313	2¼																UK213+HE2313			
UKFC213+HS2313	23/8																UK213+HS2313			
UKFC215+H2315	65	220	184	130,1	18	19	16	18	40	160	53,5	-	73	M16	64030	45885	UK215+H2315	FC215	7,67	
UKFC215+HA2315	27/16	821/32	7¼	51/8	23/32	¾	5/8	23/32	137/64	6,2992	27/64	-	2,874	5/8			UK215+HA2315			
UKFC215+HE2315	2½																UK215+HE2315			
UKFC216+H2316	70	240	200	141,4	18	23	16	18	42	170	57	-	78	M20	69065	50350	UK216+H2316	FC216	9,41	
UKFC216+HA2316	211/16	929/64	77/8	59/16	23/32	29/32	5/8	23/32	121/32	6,6929	2¼	-	3,071	¾			UK216+HA2316			
UKFC216+HE2316	2¾																UK216+HE2316			
UKFC217+H2317	75	250	208	147,1	18	23	18	20	45	180	59	-	82	M20	79800	58805	UK217+H2317	FC217	11,23	
UKFC217+HA2317	215/16	927/32	83/16	551/64	23/32	29/32	23/32	25/32	125/32	7,0866	221/64	-	3,228	¾			UK217+HA2317			
UKFC217+HE2317	3																UK217+HE2317			
UKFC218+H2318	80	265	220	155,5	22	23	18	20	50	190	64,5	-	86	M20	91295	67925	UK218+H2318	FC218	13,34	
UKFC218+HA2318	33/16	107/16	821/32	61/8	55/64	29/32	23/32	25/32	131/32	7,4803	335/64	-	3,386	¾			UK218+HA2318			

Bussole HA; HE; HS con filettatura in pollici
Inch dimension adapter sleeves HA; HE; HS

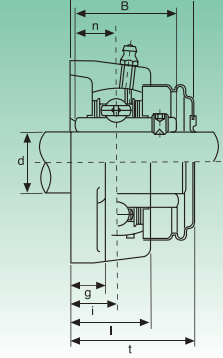
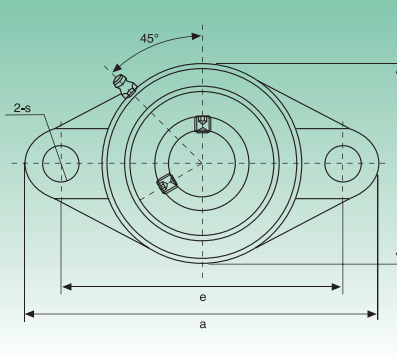
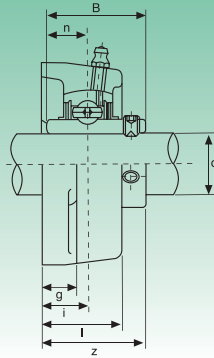

Tipo Type	Dimensioni - Dimensions												Bull. fiss. Bolt Size	Coefficients di carico (N) Load ratings (N)		Cuscinetto Bearing	Supporto Housing	Peso Weight
	d	a	e	i	g	l	s	b	z	t	B	n		Dinamico C Dynamic C	Statico C ₀ Static C ₀			
	mm/inch													mm/inch				
UCFL201 UCFL201-8	12 ½	113 47/16	90 335/64	15 19/32	11 7/16	25,5 1	12 15/32	60 23/8	33,3 15/16	37,5 131/64	31 1,2205	12,7 0,500	M10 3/8	12160	6318	UC201 UC201-8	FL204	0,45 0,44
UCFL202 UCFL202-9 UCFL202-10	15 9/16 5/8	113 47/16	90 335/64	15 19/32	11 7/16	25,5 1	12 15/32	60 23/8	33,3 15/16	37,5 131/64	31 1,2205	12,7 0,500	M10 3/8	12160	6318	UC202 UC202-9 UC202-10	FL204	0,44 0,44 0,44
UCFL203 UCFL203-11	17 11/16	113 47/16	90 335/64	15 19/32	11 7/16	25,5 1	12 15/32	60 23/8	33,3 15/16	37,5 131/64	31 1,2205	12,7 0,500	M10 3/8	12160	6318	UC203 UC203-11	FL204	0,43 0,42
UCFL204 UCFL204-12	20 ¾	113 47/16	90 335/64	15 19/32	11 7/16	25,5 1	12 15/32	60 23/8	33,3 15/16	37,5 131/64	31 1,2205	12,7 0,500	M10 3/8	12160	6318	UC204 UC204-12	FL204	0,41 0,41
UCFL205 UCFL205-13 UCFL205-14 UCFL205-15 UCFL205-16	25 13/16 7/8 15/16 1	130 51/8	99 357/64	16 5/8	13 ½	27 11/16	16 5/8	68 211/16	35,8 113/32	40 19/16	34,1 1,3425	14,3 0,563	M14 ½	13300	7457	UC205 UC205-13 UC205-14 UC205-15 UC205-16	FL205	0,58 0,62 0,61 0,59 0,58
UCFL206 UCFL206-17 UCFL206-18 UCFL206-19 UCFL206-20	30 11/16 11/8 13/16 1¼	148 513/16	117 439/64	18 45/64	13 ½	31 17/32	16 5/8	80 35/32	40,2 119/32	44,5 1¾	38,1 1,5000	15,9 0,626	M14 ½	18525	10735	UC206 UC206-17 UC206-18 UC206-19 UC206-20	FL206	0,86 0,89 0,88 0,86 0,85
UCFL207 UCFL207-20 UCFL207-21 UCFL207-22 UCFL207-23	35 1¼ 15/16 13/8 17/16	161 611/32	130 51/8	19 ¾	14 35/64	34 113/32	16 5/8	90 335/64	44,4 1¾	48,5 129/32	42,9 1,6890	17,5 0,689	M14 ½	24415	14630	UC207 UC207-20 UC207-21 UC207-22 UC207-23	FL207	1,08 1,14 1,11 1,08 1,05
UCFL208 UCFL208-24 UCFL208-25	40 1½ 19/16	175 67/8	144 543/64	21 53/64	14 35/64	36 113/32	16 5/8	100 315/16	51,2 21/64	55,5 23/16	49,2 1,9370	19 0,748	M14 ½	27645	16910	UC208 UC208-24 UC208-25	FL208	1,44 1,48 1,45
UCFL209 UCFL209-26 UCFL209-27 UCFL209-28	45 15/8 111/16 1¾	188 713/32	148 553/64	22 55/64	15 19/32	38 1½	19 ¾	108 4¼	52,2 21/16	56,5 27/32	49,2 1,9370	19 0,748	M16 5/8	32395	20235	UC209 UC209-26 UC209-27 UC209-28	FL209	1,74 1,84 1,80 1,76
UCFL210 UCFL210-29 UCFL210-30 UCFL210-31 UCFL210-32	50 113/16 17/8 115/16 2	197 7¾	157 63/16	22 55/64	15 19/32	40 137/64	19 ¾	115 417/32	54,6 25/32	59,5 211/32	51,6 2,0315	19 0,748	M16 5/8	33345	22135	UC210 UC210-29 UC210-30 UC210-31 UC210-32	FL210	2,10 2,22 2,17 2,12 2,08
UCFL211 UCFL211-32 UCFL211-33 UCFL211-34 UCFL211-35	55 2 21/16 21/8 23/16	224 813/16	184 7¼	25 63/64	18 23/32	43 111/16	19 ¾	130 51/6	58,4 25/16	63 215/32	55,6 2,1890	22,2 0,874	M16 5/8	41230	27930	UC211 UC211-32 UC211-33 UC211-34 UC211-35	FL211	2,91 3,06 3,00 2,95 2,89
UCFL212 UCFL212-36 UCFL212-37 UCFL212-38 UCFL212-39	60 2¼ 25/16 23/8 27/16	250 927/32	202 761/64	29 19/64	18 23/32	48 17/8	23 29/32	140 5½	68,7 223/32	73,5 257/64	65,1 2,5630	25,4 1,000	M20 ¾	49780	34390	UC212 UC212-36 UC212-37 UC212-38 UC212-39	FL212	3,74 3,87 3,79 3,72 3,65
UCFL213 UCFL213-40 UCFL213-41	65 2½ 29/16	258 105/32	210 817/64	30 13/16	22 7/8	50 131/32	23 29/32	155 63/32	69,7 2¾	74,5 215/16	65,1 2,5630	25,4 1,000	M20 ¾	54340	38095	UC213 UC213-40 UC213-41	FL213	4,57 4,66 4,57
UCFL214 UCFL214-42 UCFL214-43 UCFL214-44	70 25/8 211/16 2¾	265 107/16	216 8½	31 17/32	22 7/8	54 21/8	23 29/32	160 65/16	75,4 231/32	- -	74,6 2,9370	30,2 1,189	M20 ¾	59090	41895	UC214 UC214-42 UC214-43 UC214-44	FL214	5,11 5,32 5,22 5,12
UCFL215 UCFL215-45 UCFL215-46 UCFL215-47 UCFL215-48	75 213/16 27/8 215/16 3	275 1013/16	225 855/64	34 111/32	22 7/8	56 27/32	23 29/32	165 6½	78,5 33/32	- -	77,8 3,0630	33,3 1,311	M20 ¾	64030	45885	UC215 UC215-45 UC215-46 UC215-47 UC215-48	FL215	5,37 5,62 5,51 5,40 5,28
UCFL216 UCFL216-49 UCFL216-50 UCFL216-51	80 31/16 31/8 31/16	290 1113/32	233 911/64	34 111/32	22 7/8	58 29/32	25 63/64	180 73/32	83,3 39/32	- -	82,6 3,2520	33,3 1,311	M22 7/8	69065	50350	UC216 UC216-49 UC216-50 UC216-51	FL216	7,20 7,38 7,25 7,12
UCFL217 UCFL217-52 UCFL217-53 UCFL217-55	85 ¾ 35/16 37/16	305 12	248 949/64	36 127/64	24 15/16	63 215/32	25 63/64	190 715/32	87,6 37/16	- -	85,7 3,3740	34,1 1,343	M22 7/8	79800	58805	UC217 UC217-52 UC217-53 UC217-55	FL217	8,61 8,83 8,69 8,40
UCFL218 UCFL218-56	90 3½	320 1219/32	265 1071/16	40 137/64	24 15/16	68 211/16	25 63/64	205 81/16	96,3 325/32	- -	96 3,7795	39,7 1,5630	M22 7/8	91295	67925	UC218 UC218-56	FL218	10,51 10,62

Disponibile in acciaio inox Supporto: AISI 304 - Cuscinetto: AISI 440C o 420C - Available stainless steel Housing: AISI 304 - Bearing: AISI 440C or 420C
Disponibile su richiesta con cuscinetto SA (SAFL) - Available under request with SA bearing (SAFL)

HCFL2 Serie normale - Standard duty

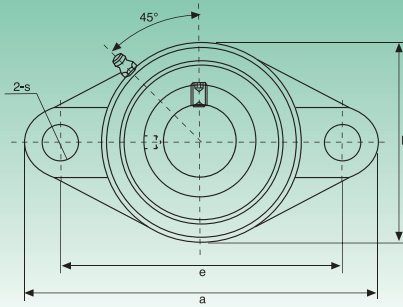
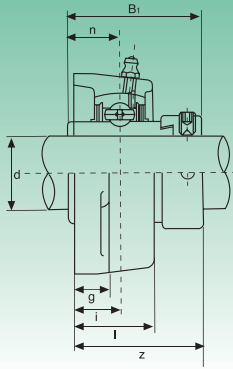

Tipo Type	Dimensioni - Dimensions											Bull. fiss. Bolt Size	Coefficienti di carico (N) Load ratings (N)		Cuscinetto Bearing	Supporto Housing	Peso Weight	
	d	a	e	i	g	l	s	b	z	B ₁	n		Dinamico C Dynamic C	Statico C ₀ Static C ₀				kg
	mm/inch												mm/inch					
HCFL204 HCFL204-12	20 ¾	113 47/16	90 335/64	15 19/32	11 7/16	25,5 1	12 15/32	60 23/8	41,6 141/64	43,7 1,720	17,1 0,673	M10 3/8	12160	6318	HC204 HC204-12	FL204	0,48 0,48	
HCFL205 HCFL205-13 HCFL205-14 HCFL205-15 HCFL205-16	25 13/16 7/8 15/16 1	130 51/8	99 357/64	16 5/8	13 ½	27 11/16	16 5/8	68 211/16	42,9 111/16	44,4 1,748	17,5 0,689	M14 ½	13300	7457	HC205 HC205-13 HC205-14 HC205-15 HC205-16	FL205	0,65 0,70 0,69 0,67 0,65	
HCFL206 HCFL206-17 HCFL206-18 HCFL206-19 HCFL206-20	30 11/16 11/8 13/16 1¼	148 513/16	117 439/64	18 45/64	13 ½	31 17/32	16 5/8	80 35/32	48,1 157/64	48,4 1,906	18,3 0,720	M14 ½	18525	10735	HC206 HC206-17 HC206-18 HC206-19 HC206-20	FL206	0,99 1,04 1,01 0,99 0,96	
HCFL207 HCFL207-20 HCFL207-21 HCFL207-22 HCFL207-23	35 1¼ 15/16 13/8 17/16	161 611/32	130 51/8	19 ¾	14 35/64	34 111/32	16 5/8	90 335/64	51,3 21/64	51,1 2,012	18,8 0,740	M14 ½	24415	14630	HC207 HC207-20 HC207-21 HC207-22 HC207-23	FL207	1,20 1,27 1,23 1,20 1,17	
HCFL208 HCFL208-24 HCFL208-25	40 1½ 19/16	175 67/8	144 543/64	21 53/64	14 35/64	36 113/32	16 5/8	100 315/16	55,9 213/64	56,3 2,217	21,4 0,843	M14 ½	27645	16910	HC208 HC208-24 HC208-25	FL208	1,59 1,64 1,60	
HCFL209 HCFL209-26 HCFL209-27 HCFL209-28	45 15/8 111/16 1¼	188 713/32	148 553/64	22 55/64	15 19/32	38 1½	19 ¾	108 4¼	56,9 215/64	56,3 2,217	21,4 0,843	M14 ½	32395	20235	HCF209 HC209-26 HC209-27 HC209-28	FL209	1,91 2,02 1,97 1,93	
HCFL210 HCFL210-29 HCFL210-30 HCFL210-31 HCFL210-32	50 113/16 17/8 115/16 2	197 7¾	157 63/16	22 55/64	15 19/32	40 137/64	19 ¾	115 417/32	60,1 223/64	62,7 2,469	24,6 0,969	M16 5/8	33345	22135	HCF210 HC210-29 HC210-30 HC210-31 HC210-32	FL210	2,29 2,44 2,38 2,32 2,26	
HCFL211 HCFL211-32 HCFL211-33 HCFL211-34 HCFL211-35	55 2 22/16 21/8 23/16	224 813/16	184 7¼	25 63/64	18 23/32	43 111/16	19 ¾	130 51/8	68,6 245/64	71,4 2,811	27,8 1,094	M16 5/8	41230	27930	HCF211 HC211-32 HC211-33 HC211-34 HC211-35	FL211	3,12 3,32 3,24 3,17 3,09	
HCFL212 HCFL212-36 HCFL212-37 HCFL212-38 HCFL212-39	60 2¼ 25/16 23/8 27/16	250 927/32	202 761/64	29 19/64	18 23/32	48 17/8	23 29/32	140 5½	75,8 263/64	77,8 3,063	31 1,220	M20 ¾	49780	34390	HC212 HC212-36 HC212-37 HC212-38 HC212-39	FL212	4,08 4,24 4,15 4,10 3,97	
HCFL213 HCFL213-40 HCFL213-41	65 2½ 29/16	258 105/32	210 817/64	30 13/16	22 7/8	50 131/32	23 29/32	155 63/32	81,6 37/32	85,7 3,374	34,1 1,343	M20 ¾	54340	38095	HC213 HC213-40 HC213-41	FL213	5,13 5,23 5,12	
HCFL214 HCFL214-42 HCFL214-43 HCFL214-44	70 23/8 211/16 2¾	265 107/16	216 8½	31 17/32	22 7/8	54 21/8	23 29/32	160 65/16	82,6 3¼	85,7 3,374	34,1 1,343	M20 ¾	59090	41895	HC214 HC214-42 HC214-43 HC214-44	FL214	5,61 5,85 5,74 5,62	
HCFL215 HCFL215-45 HCFL215-46 HCFL215-47 HCFL215-48	75 213/16 27/8 215/16 3	275 1013/16	225 855/64	34 111/32	22 7/8	56 27/32	23 29/32	165 6½	88,8 3½	92,1 3,626	37,3 1,426	M20 ¾	64030	45885	HC215 HC215-45 HC215-46 HC215-47 HC215-48	FL215	6,00 6,30 6,17 6,04 5,90	

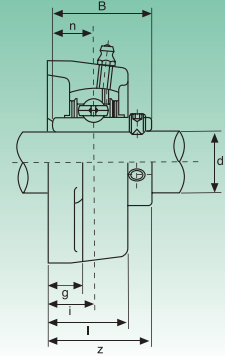
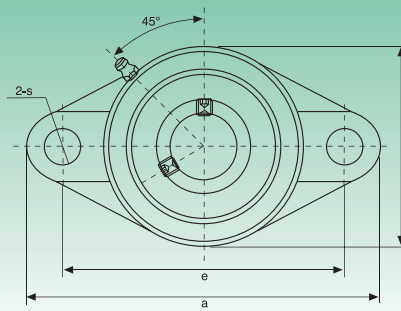

Tipo Type	Dimensioni - Dimensions											Bull. fiss. Bolt Size	Coefficients di carico (N) Load ratings (N)		Cuscinetto Bearing	Supporto Housing	Peso Weight kg
	d	a	e	i	g	l	s	b	z	B	n		Dinamico C Dynamic C	Statico C ₀ Static C ₀			
	mm/inch												mm/inch				
UCFL305 UCFL305-13 UCFL305-14 UCFL305-15 UCFL305-16	25 13/16 7/8 15/16 1	150	113	16	13	29	19	80	39	38	15	M16			UC305 UC305-13 UC305-14 UC305-15 UC305-16	FL305	1,1
UCFL306 UCFL306-17 UCFL306-18 UCFL306-19	30 11/16 11/8 13/16	180	134	18	15	32	23	90	44	43	17	M20			UC306 UC306-17 UC306-18 UC306-19	FL306	1,5
UCFL307 UCFL307-20 UCFL307-21 UCFL307-22 UCFL307-23	35 1 1/4 15/16 13/8 17/16	185	141	20	16	36	23	100	49	48	19	M20			UC307 UC307-20 UC307-21 UC307-22 UC307-23	FL307	1,9
UCFL308 UCFL308-24 UCFL308-25	40 1 1/2 19/16	200	158	23	17	40	23	112	56	52	19	M20			UC308 UC308-24 UC308-25	FL308	2,5
UCFL309 UCFL309-26 UCFL309-27 UCFL309-28	45 15/8 111/16 1 3/4	230	177	25	18	44	25	125	60	57	22	M22			UC309 UC309-26 UC309-27 UC309-28	FL309	3,4
UCFL310 UCFL310-29 UCFL310-30 UCFL310-31	50 113/16 17/8 115/16	240	187	28	19	48	25	140	67	61	22	M22			UC310 UC310-29 UC310-30 UC310-31	FL310	4,4
UCFL311 UCFL311-32 UCFL311-33 UCFL311-34 UCFL311-35	55 2 21/16 21/8 23/16	250	198	30	20	52	25	150	71	66	25	M22			UC311 UC311-32 UC311-33 UC311-34 UC311-35	FL311	5,1
UCFL312 UCFL312-36 UCFL312-37 UCFL312-38 UCFL312-39	60 2 1/4 25/16 23/8 27/16	270	212	33	22	56	31	160	78	71	26	M27			UC312 UC312-36 UC312-37 UC312-38 UC312-39	FL312	6,1
UCFL313 UCFL313-40 UCFL313-41	65 2 1/2 29/16	295	240	33	25	58	31	175	78	75	30	M27			UC313 UC313-40 UC313-41	FL313	7,8
UCFL314 UCFL314-42 UCFL314-43 UCFL314-44	70 25/8 211/16 2 3/4	315	250	36	28	61	35	185	81	78	33	M30			UC314 UC314-42 UC314-43 UC314-44	FL314	9,0
UCFL315 UCFL315-45 UCFL315-46 UCFL315-47 UCFL315-48	75 213/16 27/8 215/16 3	320	260	39	30	66	35	195	89	82	32	M30			UC315 UC315-45 UC315-46 UC315-47 UC315-48	FL315	10
UCFL316 UCFL316-49 UCFL316-50 UCFL316-51	80 31/16 31/8 33/16	355	285	38	32	68	38	210	90	86	34	M33			UC316 UC316-49 UC316-50 UC316-51	FL316	13
UCFL317 UCFL317-52 UCFL317-53 UCFL317-55	85 3 1/4 35/16 37/16	370	300	44	32	74	38	220	100	96	40	M33			UC317 UC317-52 UC317-53 UC317-55	FL317	15
UCFL318 UCFL318-55 UCFL318-56	90 37/16 3 1/2	385	315	44	36	76	38	235	100	96	40	M33			UC318 UC318-55 UC318-56	FL318	18
UCFL319 UCFL319-58 UCFL319-59 UCFL319-60	95 35/8 311/16 3 3/4	405	330	59	40	94	41	250	121	103	41	M36			UC319 UC319-58 UC319-59 UC319-60	FL319	22
UCFL320 UCFL320-61 UCFL320-62 UCFL320-63 UCFL320-64	100 313/16 37/8 315/16 4	440	360	59	40	94	44	270	125	108	42	M39			UC320 UC320-61 UC320-62 UC320-63 UC320-64	FL320	27
UCFL322	110 - 18 1/2	470	390	60	42	96	44	300	131	117	46	M39 1 1/2	194750	171000	UC322	FL322	33
UCFL324	120 - 2015/32	520	430	65	48	110	47	330	140	126	51	M42 -	196650	175750	UC324	FL324	48
UCFL326	130 - 2121/32	550	460	69	50	115	47	360	146	135	54	M42 -	217550	203300	UC326	FL326	58
UCFL328	140 - 235/8	600	500	75	60	125	51	400	161	145	59	M45 -	240350	233700	UC328	FL328	81

UCFLX Serie media - Medium duty

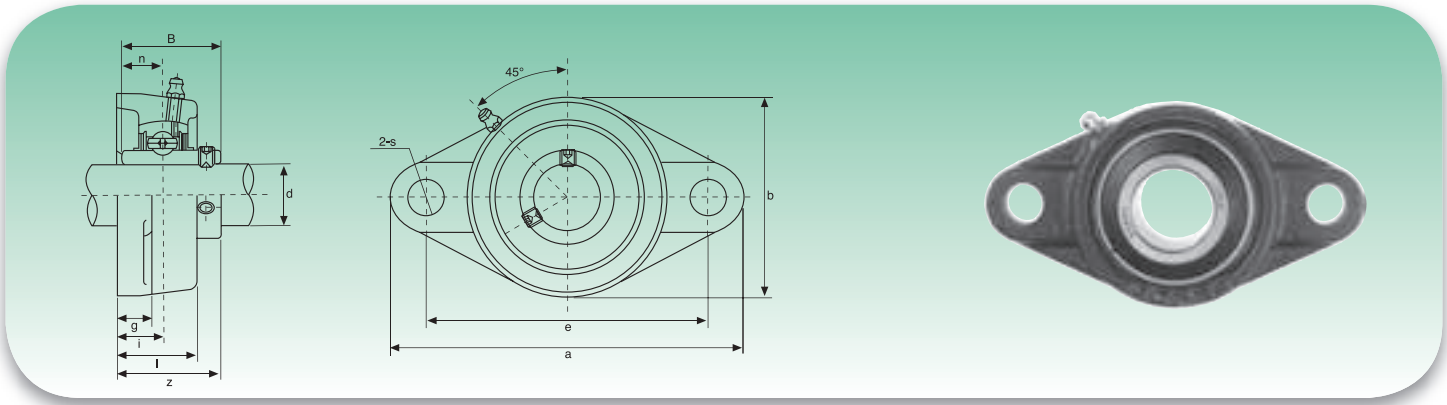

Tipo Type	Dimensioni - Dimensions											Bull. fiss. Bolt Size	Coefficients di carico (N) Load ratings (N)		Cuscinetto Bearing	Supporto Housing	Peso Weight	
	d	a	e	i	g	l	s	b	z	B	n		Dinamico C Dynamic C	Statico C ₀ Static C ₀				kg
	mm/inch																	
UCFLX05	25	141	117	18	13	30	12	83	40,2	38,1	15,9	M10	18525	10735	UCX05	FLX05	1,0	
UCFLX05-13	13/16																	
UCFLX05-14	7/8																	
UCFLX05-15	15/16	59/16	439/64	45/64	½	13/16	15/32	39/32	137/64	1,5000	0,626	3/8						
UCFLX05-16	1																	
UCFLX06	30	156	130	19	15	34	16	95	44,4	42,9	17,5	M14	24415	14630	UCX06	FLX06	1,5	
UCFLX06-17	11/16																	
UCFLX06-18	11/8																	
UCFLX06-19	13/16	65/32	51/8	¾	19/32	111/32	5/8	3¾	1¾	1,6890	0,689	½						
UCFLX06-20	1¼																	
UCFLX07	35	171	144	21	16	38	16	105	51,2	49,2	19	M14	27645	16910	UCX07	FLX07	2,0	
UCFLX07-21	15/16																	
UCFLX07-22	13/8	623/32	543/64	53/64	5/8	1½	5/8	41/8	21/64	1,9370	0,748	½						
UCFLX07-23	17/16																	
UCFLX08	40	179	148	22	16	40	16	111	52,2	49,2	19	M14	32395	20235	UCX08	FLX08	2,2	
UCFLX08-24	1½																	
UCFLX08-25	19/16	71/16	553/64	55/64	5/8	137/64	5/8	43/8	21/16	1,9370	0,748	½						
UCFLX09	45	189	157	23	16	40	16	116	55,6	51,6	19	M14	33345	22135	UCX09	FLX09	2,4	
UCFLX09-26	15/8																	
UCFLX09-27	111/16																	
UCFLX09-28	1¾	77/16	63/16	29/32	5/8	137/64	5/8	49/18	23/16	2,0315	0,748	½						
UCFLX09-29	113/16																	
UCFLX10	50	216	184	26	18	44	19	133	59,4	55,6	22,2	M16	41230	27930	UCX10	FLX10	3,4	
UCFLX10-30	17/8																	
UCFLX10-31	115/16	8½	7¼	11/32	23/32	123/32	¾	5¼	211/32	2,1890	0,874	5/8						
UCFLX10-32	2																	

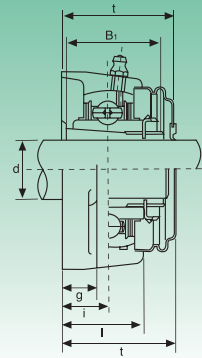
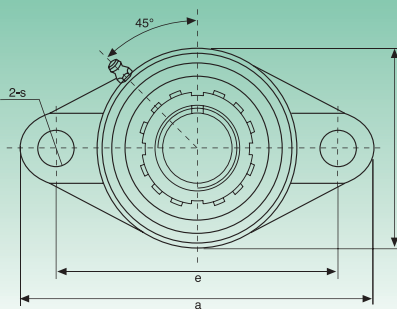
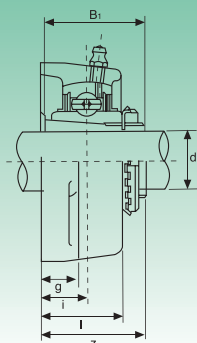
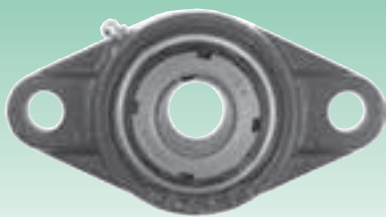
UKFL2 Serie normale - Standard duty

Tipo Type	Dimensioni - Dimensions											Bull. fiss. Bolt Size	Coefficients di carico (N) Load ratings (N)		Cuscinetto Bearing	Supporto Housing	Peso Weight
	d	a	e	i	g	l	s	b	z	t	B ₁		Dinamico C Dynamic C	Statico C ₀ Static C ₀			
	mm/inch												mm/inch				
UKFL205+H2305	20	130	99	16	13	27	16	68	35,5	40	35	M14	13300	7457	UK205+H2305	FL205	0,63
UKFL205+HE2305	¾	51/8	357/64	5/8	½	11/16	5/8	211/16	125/64	19/16	1,378	½			UK205+HE2305		
UKFL206+H2306	25	148	117	18	13	31	16	80	39	44,5	38	M14	18525	10735	UK206+H2306	FL206	0,90
UKFL206+HS2306	7/8	513/16	439/64	45/64	½	17/32	5/8	35/32	117/32	1¾	1,496	½			UK206+HS2306		
UKFL206+HE2306	1												UK206+HE2306				
UKFL207+H2307	30	161	130	19	14	34	16	90	42,5	48,5	43	M14	24415	14630	UK207+H2307	FL207	1,17
UKFL207+HE2307	11/8	611/32	51/8	¾	35/64	111/32	5/8	335/64	143/64	129/32	1,693	½			UK207+HS2307		
UKFL208+H2308	35	175	144	21	14	36	16	100	46,5	55,5	46	M14	27645	16910	UK208+H2308	FL208	1,54
UKFL208+HE2308	1¼	67/8	543/64	53/64	35/64	113/32	5/8	315/16	153/64	23/16	1,811	½			UK208+HE2308		
UKFL208+HS2308	13/8												UK208+HS2308				
UKFL209+H2309	40	188	148	22	15	38	19	108	48,5	56,5	50	M16	32395	20235	UK209+H2309	FL209	1,89
UKFL209+HA2309	17/16	713/32	553/64	55/64	19/32	1½	¾	4¾	129/32	27/32	1,969	5/8			UK209+HA2309		
UKFL209+HE2309	1½												UK209+HE2309				
UKFL209+HS2309	15/8	UK209+HS2309															
UKFL210+H2310	45	197	157	22	15	40	19	115	50	59,5	55	M16	33345	22135	UK210+H2310	FL210	2,27
UKFL210+HS2310	15/8	7¾	63/16	55/64	19/32	137/64	¾	417/32	131/32	211/32	2,165	5/8			UK210+HS2310		
UKFL210+HA2310	111/16												UK210+HA2310				
UKFL210+HE2310	1¾	UK210+HE2310															
UKFL211+H2311	50	224	184	25	18	43	19	130	54,5	63	59	M16	41230	27930	UK211+H2311	FL211	3,06
UKFL211+HS2311	17/8	813/16	7¼	63/64	23/32	111/16	¾	51/8	29/64	215/32	2,323	5/8			UK211+HS2311		
UKFL211+HA2311	115/16												UK211+HA2311				
UKFL211+HE2311	2	UK211+HE2311															
UKFL212+H2312	55	250	202	29	18	48	23	140	61	73,5	62	M20	49780	34390	UK212+H2312	FL212	3,79
UKFL212+HS2312	21/8	927/32	761/64	19/64	23/32	17/8	29/32	5½	213/32	257/64	2,441	¾			UK212+HS2312		
UKFL213+H2313	60	258	210	30	22	50	23	155	64	74,5	65	M20	54340	38095	UK213+H2313	FL213	4,48
UKFL213+HA2313	23/16	105/32	817/64	13/16	7/8	131/32	29/32	63/62	233/64	215/16	2,559	¾			UK213+HA2313		
UKFL213+HE2313	2¼												UK213+HE2313				
UKFL213+HS2313	23/8	UK213+HS2313															
UKFL215+H2315	65	275	225	34	22	56	23	165	71	-	73	M20	64030	45885	UK215+H2315	FL215	5,48
UKFL215+HA2315	27/16	1013/16	855/64	111/32	7/8	27/32	29/32	6½	251/64	-	2,874	¾			UK215+HA2315		
UKFL215+HE2315	2½												UK215+HE2315				
UKFL216+H2316	70	290	233	34	22	58	25	180	73,5	-	78	M22	69065	50350	UK216+H2316	FL216	7,46
UKFL216+HA2316	211/16	1113/32	911/64	111/32	7/8	29/32	63/64	73/32	257/64	-	3,071	7/8			UK216+HA2316		
UKFL216+HE2316	2¾												UK216+HE2316				
UKFL217+H2317	75	305	248	36	24	63	25	190	77	-	82	M22	79800	58805	UK217+H2317	FL217	9,03
UKFL217+HA2317	215/16	12	949/64	127/64	15/16	215/32	63/64	715/32	31/32	-	3,228	7/8			UK217+HA2317		
UKFL217+HE2317	3												UK217+HE2317				
UKFL218+H2318	80	320	265	40	24	68	25	205	81,5	-	86	M22	91295	67925	UK218+H2318	FL218	10,89
UKFL218+HA2318	33/16	1219/32	107/16	137/64	15/16	211/16	63/64	81/16	313/64	-	3,386	7/8			UK218+HA2318		

Bussole HA; HE; HS con filettatura in pollici
Inch dimension adapter sleeves HA; HE; HS

UKFLX Serie media - Medium duty

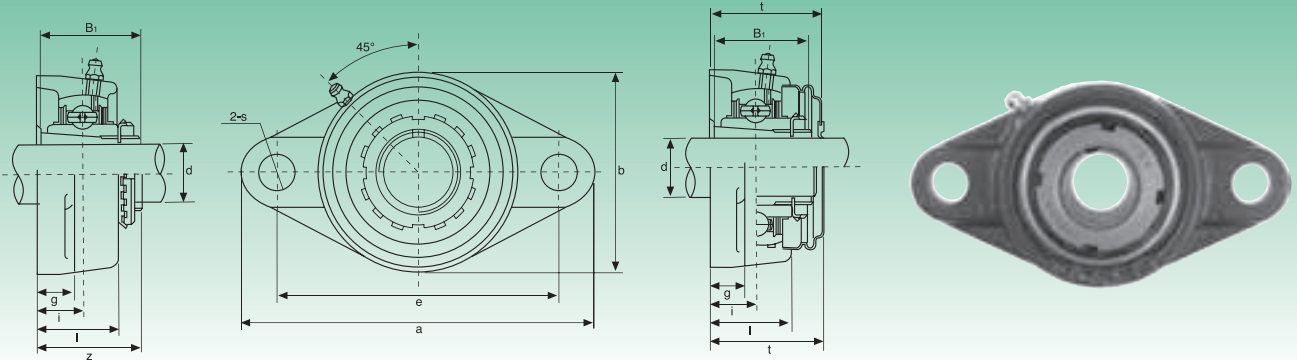

Tipo Type	Dimensioni - Dimensions										Bull. fiss. Bolt Size	Coefficienti di carico (N) Load ratings (N)		Cuscinetto Bearing	Supporto Housing	Peso Weight	
	d	a	e	i	g	l	s	b	z	B ₁		Dinamico C Dynamic C	Statico C ₀ Static C ₀				kg
	mm/inch											mm/inch					
UKFLX05+H2305	20	141	117	18	13	30	12	83	39	35	M10	18525	10735	UKX05+H2305	FLX05	1,0	
UKFLX05+HE2305	¾	59/16	439/64	45/64	½	13/16	15/32	39/32	117/32	1,378	3/8			UKX05+HE2305			
UKFLX06+H2306	25	156	130	19	15	34	16	95	41,5	38	M14	24415	14630	UKX06+H2306	FLX06	1,5	
UKFLX06+HS2306	7/8	65/32	51/8	¾	19/32	111/32	5/8	3¾	141/64	1,496	½			UKX06+HS2306			
UKFLX06+HE2306	1													UKX06+HE2306			
UKFLX07+H2307	30	171	144	21	16	38	16	105	45,5	43	M14	27645	16910	UKX07+H2307	FLX07	1,8	
UKFLX07+HS2307	11/8	623/32	543/64	53/64	5/8	1½	5/8	41/8	151/64	1,693	½			UKX07+HS2307			
UKFLX08+H2308	35	179	148	22	16	40	16	111	47,5	46	M14	32395	20235	UKX08+H2308	FLX08	2,1	
UKFLX08+HE2308	1¾	71/16	553/64	55/64	5/8	19/16	5/8	43/8	17/8	1,811	½			UKX08+HE2308			
UKFLX08+HS2308	13/8													UKX08+HS2308			
UKFLX09+H2309	40	189	157	23	16	40	16	116	50	50	M14	33345	22135	UKX09+H2309	FLX09	2,5	
UKFLX09+HA2309	17/16	77/16	63/16	29/32	5/8	137/64	5/8	49/16	131/32	1,969	½			UKX09+HA2309			
UKFLX09+HE2309	1½													UKX09+HE2309			
UKFLX09+HS2309	15/8													UKX09+HS2309			
UKFLX10+H2310	45	216	184	26	18	44	19	133	55,5	55	M16	41230	27930	UKX10+H2310	FLX10	3,7	
UKFLX10+HS2310	15/8	111/16	7¼	11/32	23/32	123/32	¾	5¼	23/16	2,165	5/8			UKX10+HS2310			
UKFLX10+HA2310	8½													UKX10+HA2310			
UKFLX10+HE2310	1¾													UKX10+HE2310			

Bussole HA; HE; HS con filettatura in pollici
Inch dimension adapter sleeves HA; HE; HS

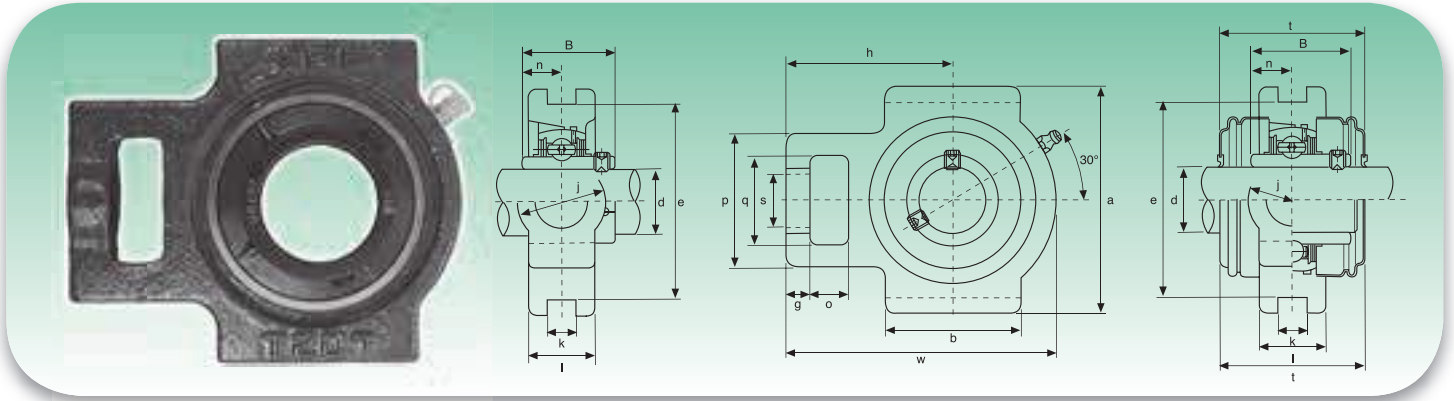

Tipo Type	Dimensioni - Dimensions																Coefficienti di carico (N) Load ratings (N)		Cuscinetto Bearing	Supporto Housing	Peso Weight	
	d	o	g	p	q	s	b	k	e	a	w	j	l	h	t	B	N	Dinamico C Dynamic C _o				Statico C _o Static C _o
	mm/inch																					
UCT201 UCT201-8	12 ½	16 5/8	10 25/64	51 11/64	32 1¼	19 ¾	51 21/64	12 15/32	76 263/64	89 3½	94 311/16	32 1¼	24 15/16	61 213/32	44,5 1¾	31 1,2205	12,7 0,500	12160	6318	UC201 UC201-8	T204	0,80 0,79
UCT202 UCT202-9 UCT202-10	15 9/16 5/8	16 5/8	10 25/64	51 11/64	32 1¼	19 ¾	51 21/64	12 15/32	76 263/64	89 3½	94 311/16	32 1¼	24 15/16	61 213/32	44,5 1¾	31 1,2205	12,7 0,500	12160	6318	UC202 UC202-9 UC202-10	T204	0,79 0,79 0,79
UCT203 UCT203-11	17 11/16	16 5/8	10 25/64	51 11/64	32 1¼	19 ¾	51 21/64	12 15/32	76 263/64	89 3½	94 311/16	32 1¼	24 15/16	61 213/32	44,5 1¾	31 1,2205	12,7 0,500	12160	6318	UC203 UC203-11	T204	0,78 0,77
UCT204 UCT204-12	20 ¾	16 5/8	10 25/64	51 11/64	32 1¼	19 ¾	51 21/64	12 15/32	76 263/64	89 3½	94 311/16	32 1¼	24 15/16	61 213/32	44,5 1¾	31 1,2205	12,7 0,500	12160	6318	UC204 UC204-12	T204	0,76 0,76
UCT205 UCT205-13 UCT205-14 UCT205-15 UCT205-16	25 13/16 7/8 15/16 1	16 5/8	10 25/64	51 11/64	32 1¼	19 ¾	51 21/64	12 15/32	76 263/64	89 3½	97 313/16	32 1¼	24 15/16	62 27/16	48 17/8	34,1 1,3425	14,3 0,563	13300	7457	UC205 UC205-13 UC205-14 UC205-15 UC205-16	T205	0,81 0,85 0,84 0,82 0,81
UCT206 UCT206-17 UCT206-18 UCT206-19 UCT206-20	30 11/16 11/8 13/16 1¼	16 5/8	10 25/64	56 27/32	37 129/64	22 55/64	57 2¼	12 15/32	89 3½	102 41/64	113 429/64	37 129/64	28 13/32	70 2¾	53 23/32	38,1 1,5000	15,9 0,626	18525	10735	UC206 UC206-17 UC206-18 UC206-19 UC206-20	T206	1,22 1,23 1,24 1,22 1,21
UCT207 UCT207-20 UCT207-21 UCT207-22 UCT207-23	35 1¼ 15/16 13/8 17/16	16 5/8	13 33/64	64 233/64	37 129/64	22 55/64	64 233/64	12 15/32	89 3½	102 41/64	129 55/64	37 129/64	30 13/16	78 35/64	59,5 211/32	42,9 1,6890	17,5 0,689	24415	14630	UC207 UC207-20 UC207-21 UC207-22 UC207-23	T207	1,44 1,50 1,48 1,44 1,41
UCT208 UCT208-24 UCT208-25	40 1½ 19/16	19 ¾	16 5/8	83 317/64	49 115/16	29 19/64	83 317/64	16 5/8	102 41/64	117 431/64	144 543/64	49 115/16	35 13/8	89 3½	69 223/32	49,2 1,9370	19 0,748	27645	16910	UC208 UC208-24 UC208-25	T208	2,40 2,44 2,41
UCT209 UCT209-26 UCT209-27 UCT209-28	45 15/8 11/16 1¾	19 ¾	16 5/8	83 317/64	49 115/16	29 19/64	83 317/64	16 5/8	102 41/64	117 439/64	144 543/64	49 115/16	35 13/8	87 327/64	69 223/32	49,2 1,9370	19 0,748	32395	20235	UC209 UC209-26 UC209-27 UC209-28	T209	2,36 2,46 2,42 2,38
UCT210 UCT210-29 UCT210-30 UCT210-31 UCT210-32	50 113/16 17/8 115/16 2	19 ¾	16 5/8	83 317/64	49 115/16	29 19/64	86 317/64	16 5/8	102 41/64	117 439/64	149 555/64	49 115/16	35 13/8	90 335/64	74,5 215/16	51,6 2,0315	19 0,748	33345	22135	UC210 UC210-29 UC210-30 UC210-31 UC210-32	T210	2,43 2,55 2,50 2,45 2,41
UCT211 UCT211-32 UCT211-33 UCT211-34 UCT211-35	55 2 21/16 21/8 23/16	25 63/64	19 ¾	102 41/64	64 21/32	35 13/8	95 3¾	22 55/64	130 51/8	146 5¾	171 647/64	64 233/64	41 15/8	106 411/64	76 3	55,6 2,1890	22,2 0,874	41230	27930	UC211 UC211-32 UC211-33 UC211-34 UC211-35	T211	4,11 4,26 4,20 4,15 4,09
UCT212 UCT212-36 UCT212-37 UCT212-38 UCT212-39	60 2¼ 25/16 23/8 27/16	32 117/64	19 ¾	102 41/64	64 21/32	35 13/8	102 41/64	22 55/64	130 51/8	146 5¾	194 741/64	64 233/64	46 113/16	119 411/16	89 3½	65,1 2,5630	25,4 1,000	49780	34390	UC212 UC212-36 UC212-37 UC212-38 UC212-39	T212	4,97 5,10 5,02 4,95 4,88
UCT213 UCT213-40 UCT213-41	65 2½ 29/16	32 117/64	21 53/64	111 43/8	70 2¾	41 139/64	121 449/64	26 11/32	151 515/16	167 637/64	224 813/16	70 2¾	51 2	137 525/64	89 3½	65,1 2,5630	25,4 1,000	54340	38095	UC213 UC213-40 UC213-41	T213	6,65 6,74 6,65
UCT214 UCT214-42 UCT214-43 UCT214-44	70 25/8 21/16 2¾	32 117/64	21 53/64	111 43/8	70 2¾	41 139/64	121 449/64	26 11/32	151 515/16	167 637/64	224 813/16	70 2¾	46 113/16	137 525/64	-	74,6 2,9370	30,2 1,189	59090	41895	UC214 UC214-42 UC214-43 UC214-44	T214	7,05 7,26 7,16 7,06
UCT215 UCT215-45 UCT215-46 UCT215-47 UCT215-48	75 23/16 27/8 215/16 3	32 117/64	21 53/64	111 43/8	70 2¾	41 139/64	121 449/64	26 11/32	151 515/16	167 637/64	232 99/64	70 2¾	48 157/64	140 533/64	-	77,8 3,0630	33,3 1,311	64030	45885	UC215 UC215-45 UC215-46 UC215-47 UC215-48	T215	7,41 7,66 7,55 7,44 7,32
UCT216 UCT216-49 UCT216-50 UCT216-51	80 31/16 31/8 33/16	32 117/64	21 53/64	111 43/8	70 2¾	41 139/64	121 449/64	26 11/32	165 6½	184 7¼	235 9¼	70 2¾	51 2	140 533/64	-	82,6 3,2520	33,3 1,311	69065	50350	UC216 UC216-49 UC216-50 UC216-51	T216	8,30 8,48 8,35 8,22
UCT217 UCT217-52 UCT217-53 UCT217-55	85 3¼ 35/16 37/16	38 1½	29 19/64	124 47/8	73 27/8	48 157/64	157 63/16	30 13/16	173 613/16	198 751/64	260 1015/64	73 27/8	54 21/8	162 63/8	-	85,7 3,3740	34,1 1,343	79800	58805	UC217 UC217-52 UC217-53 UC217-55	T217	11,00 11,22 11,09 10,80
UCT218 UCT218-56	90 35/64	41 15/8	31 1,2205	132 513/64	81 36/32	48 157/64	151 561/64	30 13/16	189 751/64	216 8½	280 1113/32	80 35/32	55 2,165	173 613/16	-	96 3,7795	39,7 118/32	91295	67925	UC218 UC218-56	T218	12,75 10,62

Disponibile in acciaio inox Supporto: AISI 304 - Cuscinetto: AISI 440C o 420C - Available stainless steel Housing: AISI 304 - Bearing: AISI 440C or 420C
Disponibile su richiesta con cuscinetto SA (SAT.) - Available under request with SA bearing (SAT.)

HCT2 Serie normale - Normal duty

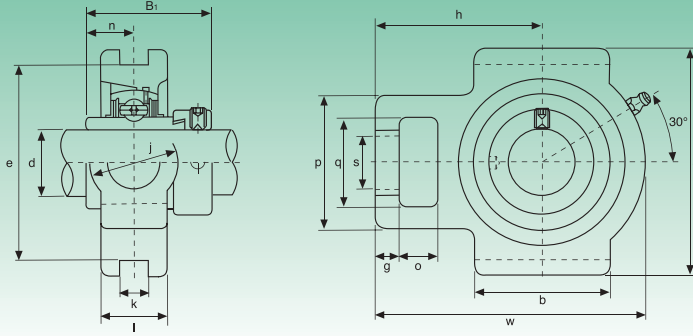

Tipo Type	Dimensioni - Dimensions																Coefficients di carico (N) Load ratings (N)		Cuscinetto Bearing	Supporto Housing	Peso Weight
	d	o	g	p	q	s	b	k	e	a	w	j	i	h	B ₁	n	Dinamico C _o Dynamic C _o	Statico C _o Static C _o			
	mm/inch																				
HCT204	20	16	10	51	32	19	51	12	76	89	94	32	24	61	43,7	17,1	12160	6318	HC204	T204	0,83
HCT204-12	¾	5/8	25/64	11/16	1¼	¾	21/64	15/32	263/64	3½	311/16	1¼	15/16	213/32	1,720	0,673			HC204-12		0,83
HCT205	25	16	10	51	32	19	51	12	76	89	97	32	24	62	44,4	17,5	13300	7457	HC205	T205	0,88
HCT205-13	13/16																		HC205-13		0,93
HCT205-14	7/8																		HC205-14		0,92
HCT205-15	15/16	5/8	25/64	11/16	1¼	¾	21/64	15/32	263/64	3½	313/16	1¼	15/16	27/16	1,748	0,689			HC205-15		0,90
HCT205-16	1																		HC205-16		0,88
HCT206	30	16	10	56	37	22	57	12	89	102	113	37	28	70	48,4	18,3	18525	10735	HC206	T206	1,35
HCT206-17	11/16																		HC206-17		1,40
HCT206-18	11/8																		HC206-18		1,37
HCT206-19	13/16	5/8	25/64	27/32	129/64	55/64	2¼	15/32	3½	41/64	429/64	129/64	13/32	2¾	1,906	0,720			HC206-19		1,35
HCT206-20	1¼																		HC206-20		1,32
HCT207	35	16	13	64	37	22	64	12	89	102	129	37	30	78	51,1	18,8	24415	14630	HC207	T207	1,56
HCT207-20	1¼																		HC207-20		1,63
HCT207-21	15/16																		HC207-21		1,59
HCT207-22	13/8	5/8	33/64	233/64	129/64	55/64	233/64	15/32	3½	41/64	55/64	129/64	13/16	35/64	2,012	0,740			HC207-22		1,56
HCT207-23	17/16																		HC207-23		1,53
HCT208	40	19	16	83	49	29	83	16	102	114	144	49	35	89	56,3	21,4	27645	16910	HC208	T208	2,55
HCT208-24	1½	¾	5/8	317/64	115/16	19/64	317/64	5/8	41/64	431/64	543/64	115/16	13/8	3½	2,217	0,843			HC208-24		2,60
HCT208-25	19/16																		HC208-25		2,56
HCT209	45	19	16	83	49	29	83	16	102	117	144	49	35	87	56,3	21,4	32395	20235	HCF209	T209	2,53
HCT209-26	15/8																		HC209-26		2,64
HCT209-27	111/16	¾	5/8	317/64	115/16	19/64	317/64	5/8	41/64	439/64	543/64	115/16	13/8	327/64	2,217	0,843			HC209-27		2,59
HCT209-28	1¾																		HC209-28		2,55
HCT210	50	19	16	83	49	29	86	16	102	117	149	49	35	90	6,7	24,6	33345	22135	HCF210	T210	2,62
HCT210-29	113/16																		HC210-29		2,77
HCT210-30	17/8	¾	5/8	317/64	115/16	19/64	325/64	5/8	41/64	439/64	555/64	115/16	13/8	335/64	2,469	0,969			HC210-30		2,71
HCT210-31	115/16																		HC210-31		2,65
HCT210-32	2																HC210-32	2,59			
HCT211	55	25	19	102	64	35	95	22	130	146	171	64	41	106	71,4	27,8	41230	27930	HCF211	T211	4,32
HCT211-32	2																		HC211-32		4,52
HCT211-33	22/16																		HC211-33		4,44
HCT211-34	21/8	63/64	¾	41/64	21/32	13/8	3¾	55/64	51/8	5¾	647/64	233/64	15/8	411/64	2,811	1,094			HC211-34		4,37
HCT211-35	23/16																		HC211-35		4,29
HCT212	60	32	19	102	64	35	102	22	130	146	194	64	46	119	77,8	31	49780	34390	HC212	T212	5,31
HCT212-36	2¼																		HC212-36		5,47
HCT212-37	25/16																		HC212-37		5,38
HCT212-38	23/8	117/64	¾	41/64	21/32	13/8	41/64	55/64	51/8	5¾	741/64	233/64	113/16	411/16	3,063	1,220			HC212-38		5,33
HCT212-39	27/16																		HC212-39		5,20
HCT213	65	32	21	111	70	41	121	26	151	167	224	70	51	137	85,7	34,1	54340	38095	HC213	T213	7,21
HCT213-40	2½																		HC213-40		7,31
HCT213-41	29/16	117/64	53/64	43/8	2¾	139/64	449/64	11/32	515/16	6637/64	8183/16	2¾	2	525/64	3,374	1,343			HC213-41		7,20
HCT214	70	32	21	111	70	41	121	26	151	167	224	70	46	137	85,7	34,1	59090	41895	HC214	T214	7,55
HCT214-42	23/8																		HC214-42		7,79
HCT214-43	211/16	117/64	53/64	43/8	2¾	139/64	449/64	11/32	515/16	6637/64	8183/16	2¾	113/16	525/64	3,374	1,343			HC214-43		7,68
HCT214-44	2¾																		HC214-44		7,56
HCT215	75	32	21	111	70	41	121	26	151	167	232	70	48	140	92,1	37,3	64030	45885	HC215	T215	8,04
HCT215-45	213/16																		HC215-45		8,34
HCT215-46	27/8																		HC215-46		8,21
HCT215-47	215/16	117/64	53/64	43/8	2¾	139/64	449/64	11/32	515/16	6637/64	99/64	2¾	157/64	533/64	3,626	1,426			HC215-47		8,08
HCT215-48	3																		HC215-48		7,94

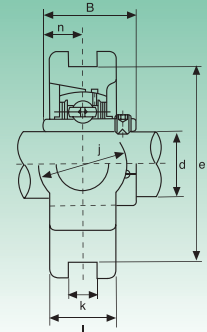
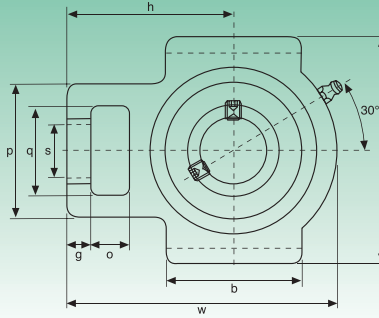

Tipo Type	Dimensioni - Dimensions																Coefficients di carico (N) Load ratings (N)		Cuscinetto Bearing	Supporto Housing	Peso Weight kg
	d	o	g	p	q	s	b	k	e	a	w	j	l	h	B	n	Dinamico C Dynamic C	Statico C ₀ Static C ₀			
	mm/inch																				
UCT305 UCT305-13 UCT305-14 UCT305-15 UCT305-16	25 13/16 7/8 15/16 1	16	14	62	36	26	65	12	80	89	122	36	26	76	38	15	20140	10355	UC305 UC305-13 UC305-14 UC305-15 UC305-16	T305	1,4
UCT306 UCT306-17 UCT306-18 UCT306-19	30 11/16 11/8 13/16	18	16	70	41	28	74	16	90	100	137	41	28	85	43	17	25365	14250	UC306 UC306-17 UC306-18 UC306-19	T306	1,8
UCT307 UCT307-20 UCT307-21 UCT307-22 UCT307-23	35 1 1/4 15/16 13/8 17/16	20	17	75	45	30	80	16	100	111	150	45	32	94	48	19	31730	18335	UC307 UC307-20 UC307-21 UC307-22 UC307-23	T307	2,4
UCT308 UCT308-24 UCT308-25	40 1 1/2 19/6	22	19	83	50	32	89	18	112	124	162	50	34	100	52	19	38665	22800	UC308 UC308-24 UC308-25	T308	3,0
UCT309 UCT309-26 UCT309-27 UCT309-28	45 15/8 11/16 1 3/4	24	20	90	55	34	97	18	125	138	178	55	38	110	57	22	46455	28025	UC309 UC309-26 UC309-27 UC309-28	T309	4,0
UCT310 UCT310-29 UCT310-30 UCT310-31	50 113/16 17/8 115/16	27	22	98	61	37	106	20	140	151	192	61	40	118	61	22	58900	36385	UC310 UC310-29 UC310-30 UC310-31	T310	5,0
UCT311 UCT311-32 UCT311-33 UCT311-34 UCT311-35	55 2 21/16 21/8 23/16	29	23	105	66	39	115	22	150	163	207	66	44	127	66	25	68020	42750	UC311 UC311-32 UC311-33 UC311-34 UC311-35	T311	6,4
UCT312 UCT312-36 UCT312-37 UCT312-38 UCT312-39	60 2 1/4 25/16 23/8 27/16	31	25	113	71	41	123	22	160	178	220	71	46	135	71	26	77805	49590	UC312 UC312-36 UC312-37 UC312-38 UC312-39	T312	7,6
UCT313 UCT313-40 UCT313-41	65 2 1/2 29/16	32	27	116	70	43	134	26	170	190	238	80	50	146	75	30	88065	56905	UC313 UC313-40 UC313-41	T313	9,7
UCT314 UCT314-42 UCT314-43 UCT314-44	70 25/8 211/16 2 3/4	36	27	130	85	46	140	26	180	202	252	90	52	155	78	33	98800	64790	UC314 UC314-42 UC314-43 UC314-44	T314	11
UCT315 UCT315-45 UCT315-46 UCT315-47 UCT315-48	75 213/16 27/8 215/16 3	36	27	132	85	46	150	26	192	216	262	90	55	160	82	32	107350	73340	UC315 UC315-45 UC315-46 UC315-47 UC315-48	T315	14
UCT316 UCT316-49 UCT316-50 UCT316-51	80 31/16 31/8 33/16	42	30	150	98	53	160	30	204	230	282	102	60	174	86	34	116850	82365	UC316 UC316-49 UC316-50 UC316-51	T316	16
UCT317 UCT317-52 UCT317-53 UCT317-55	85 3 1/4 35/16 37/16	42	32	152	98	53	170	32	214	240	298	102	64	183	96	40	126350	91960	UC317 UC317-52 UC317-53 UC317-55	T317	20
UCT318 UCT318-55 UCT318-56	90 37/16 3 1/2	46	32	160	106	57	175	32	228	255	312	110	66	192	96	40	135850	101650	UC318 UC318-55 UC318-56	T318	22
UCT319 UCT319-58 UCT319-59 UCT319-60	95 35/8 311/16 3 3/4	46	33	165	106	57	180	35	240	270	322	110	72	197	103	41	145350	113050	UC319 UC319-58 UC319-59 UC319-60	T319	24
UCT320 UCT320-61 UCT320-62 UCT320-63 UCT320-64	100 313/16 37/8 315/16 4	48	34	175	115	59	200	35	260	290	345	120	75	210	108	42	164350	133950	UC320 UC320-61 UC320-62 UC320-63 UC320-64	T320	32
UCT322 -	110 21/16	52	38	185	125	65	215	38	285	320	385	130	80	235	117	46	194750	171000	UC322	T322	40
UCT324 -	120 23/8	60	42	210	140	70	230	45	320	355	432	140	90	267	126	51	196650	175750	UC324	T324	55
UCT326 -	130 29/16	65	45	220	150	75	240	50	350	385	465	150	100	285	135	54	217550	203300	UC326	T326	69
UCT328 -	140 2 1/4	70	50	230	160	80	255	50	380	415	515	155	100	315	145	59	240350	233700	UC328	T328	84

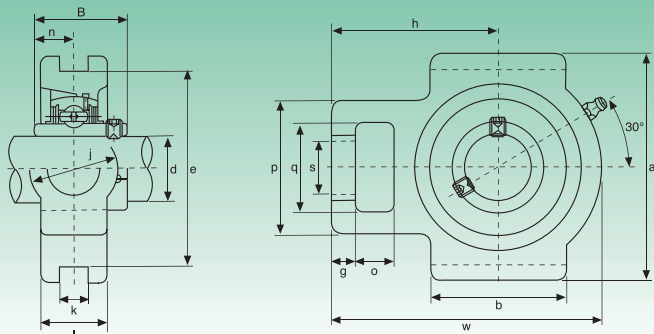

Tipo Type	Dimensioni - Dimensions															Coefficients di carico (N) Load ratings (N)		Cuscinetto Bearing	Supporto Housing	Peso Weight	
	d	o	g	p	q	s	b	k	e	a	w	j	l	h	B	n	Dinamico C Dynamic C _o				Statico C _o Static C _o
	mm/inch																			kg	
UCTX05 UCTX05-13 UCTX05-14 UCTX05-15 UCTX05-16	25 13/16 7/8 15/16 1	16	12	56	37	22	57	12	89	102	113	28	37	70	38,1	15,9	18525	10735	UCTX05 UCTX05-13 UCTX05-14 UCTX05-15 UCTX05-16	TX05	1,4
UCTX06 UCTX06-17 UCTX06-18 UCTX06-19 UCTX06-20	30 11/16 11/8 13/16 1 1/4	16	15	64	37	22	64	12	89	102	129	30	37	78	42,9	17,5	24415	14630	UCTX06 UCTX06-17 UCTX06-18 UCTX06-19 UCTX06-20	TX06	1,8
UCTX07 UCTX07-21 UCTX07-22 UCTX07-23	35 15/16 13/8 17/16	19	17	83	49	29	83	16	102	114	144	36	49	88	49,2	19	27645	16910	UCTX07 UCTX07-21 UCTX07-22 UCTX07-23	TX07	2,6
UCTX08 UCTX08-24 UCTX08-25	40 1 1/2 19/16	19	17	83	49	29	83	16	102	117	144	36	49	87	49,2	19	32395	20235	UCTX08 UCTX08-24 UCTX08-25	TX08	2,6
UCTX09 UCTX09-26 UCTX09-27 UCTX09-28 UCTX09-29	45 15/8 11/16 1 3/4 113/16	19	18	83	49	29	86	16	102	117	151	38	49	92	51,6	19	33345	22135	UCTX09 UCTX09-26 UCTX09-27 UCTX09-28 UCTX09-29	TX09	2,8
UCTX10 UCTX10-30 UCTX10-31 UCTX10-32	50 17/8 115/16 2	25	21	102	64	35	95	22	130	146	171	42	64	106	55,6	22,2	41230	27930	UCTX10 UCTX10-30 UCTX10-31 UCTX10-32	TX10	4,3
UCTX11 UCTX11-33 UCTX11-34 UCTX11-35 UCTX11-36 UCTX11-37	55 21/16 21/8 23/16 2 1/4 25/16	32	21	102	64	35	102	22	130	146	194	44	64	119	65,1	25,4	49780	34390	UCTX11 UCTX11-33 UCTX11-34 UCTX11-35 UCTX11-36 UCTX11-37	TX11	5,2
UCTX12 UCTX12-38 UCTX12-39	60 23/8 27/16	32	23	111	70	41	121	26	151	167	224	48	70	137	65,1	25,4	54340	38095	UCTX12 UCTX12-38 UCTX12-39	TX12	7,6
UCTX13 UCTX13-40 UCTX13-41	65 2 1/2 29/16	32	23	111	70	41	121	26	151	167	224	48	70	137	74,6	30,2	59090	41895	UCTX13 UCTX13-40 UCTX13-41	TX13	7,6
UCTX14 UCTX14-42 UCTX14-43 UCTX14-44	70 25/8 211/16 2 3/4	32	23	111	70	41	121	26	151	167	232	48	70	140	77,8	33,3	64030	45885	UCTX14 UCTX14-42 UCTX14-43 UCTX14-44	TX14	7,7
UCTX15 UCTX15-45 UCTX15-46 UCTX15-47 UCTX15-48	75 213/16 27/8 215/16 3	32	23	111	70	41	121	28	165	184	235	48	70	140	82,6	33,3	69065	50350	UCTX15 UCTX15-45 UCTX15-46 UCTX15-47 UCTX15-48	TX15	7,55
UCTX16 UCTX16-49 UCTX16-50 UCTX16-51 UCTX16-52	80 31/16 31/8 33/16 3 1/4	38	30	124	73	48	157	28	173	198	260	54	73	162	85,7	34,1	79800	58805	UCTX16 UCTX16-49 UCTX16-50 UCTX16-51 UCTX16-52	TX16	11
UCTX17 UCTX17-53 UCTX17-54	85 35/16 37/16	38	30	124	73	48	157	28	173	198	260	54	73	162	96	39,7	91295	67925	UCTX17 UCTX17-53 UCTX17-54	TX17	12

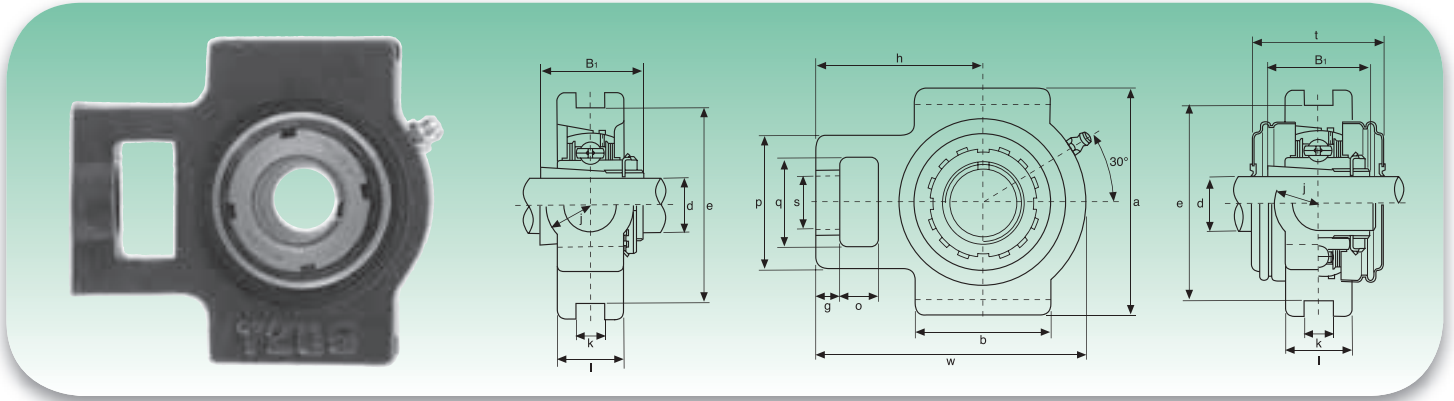
UKT2 Serie normale - Standard duty

Tipo Type	Dimensioni - Dimensions																Coefficienti di carico (N) Load ratings (N)		Cuscinetto Bearing	Supporto Housing	Peso Weight
	d	o	g	p	q	s	b	k	e	a	w	j	l	h	t	B ₁	Dinamico C Dynamic C _o	Statico C _o Static C _o			
	mm/inch																				
UKT205+H2305 UKT205+HE2305	20 ¾	16 5/8	10 25/64	51 11/64	32 1¼	19 ¾	51 21/64	12 15/32	76 263/64	89 3½	97 313/16	32 1¼	24 15/16	62 27/16	48 17/8	35 1,378	13300	7457	UK205+H2305 UK205+HE2305	T205	0,86
UKT206+H2306 UKT206+HS2306 UKT206+HE2306	25 7/8 1	16 5/8	10 25/64	56 27/32	37 115/32	22 55/64	57 2¼	12 15/32	89 3½	102 41/64	113 429/64	37 129/64	30 13/32	78 2¾	59,5 23/32	43 1,496	18525	10735	UK206+H2306 UK206+HS2306 UK206+HE2306	T206	1,26
UKT207+H2307 UKT207+HS2307	30 11/8	16 5/8	13 33/64	64 233/64	37 115/32	22 55/64	64 233/64	12 15/32	89 3½	102 41/64	129 55/64	37 129/64	30 13/16	78 35/64	59,5 211/32	43 1,693	24415	14630	UK207+H2307 UK207+HS2307	T207	2,50
UKT208+H2308 UKT208+HE2308 UKT208+HS2308	35 1¼ 13/8	19 ¾	16 5/8	83 317/64	49 115/16	29 19/64	83 317/64	16 5/8	102 41/64	114 431/64	144 543/64	49 115/16	35 13/8	89 3½	69 223/32	46 1,811	27645	16910	UK208+H2308 UK208+HE2308 UK208+HS2308	T208	2,50
UKT209+H2309 UKT209+HA2309 UKT209+HE2309 UKT209+HS2309	40 17/16 1½ 15/8	19 ¾	16 5/8	83 317/64	49 115/16	29 19/64	83 317/64	16 5/8	102 41/64	117 439/64	144 543/64	49 115/16	35 13/8	87 327/64	69 223/32	50 1,969	32395	20235	UK209+H2309 UK209+HA2309 UK209+HE2309 UK209+HS2309	T209	2,51
UKT210+H2310 UKT210+HS2310 UKT210+HA2310 UKT210+HE2310	45 15/8 111/16 1¾	19 ¾	16 5/8	83 317/64	49 115/16	29 19/64	86 325/64	16 5/8	102 41/64	117 439/64	149 555/64	49 115/16	35 13/8	90 335/64	74,5 215/16	55 2,165	33345	22135	UK210+H2310 UK210+HS2310 UK210+HA2310 UK210+HE2310	T210	2,60
UKT211+H2311 UKT211+HS2311 UKT211+HA2311 UKT211+HE2311	50 17/8 115/16 2	25 63/64	19 ¾	102 41/64	64 21/32	35 13/8	95 3¾	22 55/64	130 51/8	146 5¾	171 647/64	64 233/64	41 15/8	106 411/64	76 3	59 2,323	41230	27930	UK211+H2311 UK211+HS2311 UK211+HA2311 UK211+HE2311	T211	4,26
UKT212+H2312 UKT212+HS2312	55 21/8	32 117/64	19 ¾	102 41/64	64 21/32	35 13/8	102 41/64	22 55/64	130 51/8	146 5¾	194 741/64	64 233/64	46 113/16	119 411/16	89 3½	62 2,441	49780	34390	UK212+H2312 UK212+HS2312	T212	5,02
UKT213+H2313 UKT213+HA2313 UKT213+HE2313 UKT213+HS2313	60 23/16 2¼ 23/8	32 117/64	21 53/64	111 43/8	70 2¾	41 139/64	121 449/64	26 11/32	151 515/16	167 637/64	224 813/16	70 2¾	51 2	137 525/64	89 3½	65 2,559	54340	38095	UK213+H2313 UK213+HA2313 UK213+HE2313 UK213+HS2313	T213	6,56
UKT215+H2315 UKT215+HA2315 UKT215+HE2315	65 27/16 2½	32 117/64	21 53/64	111 43/8	70 2¾	41 139/64	121 449/64	26 11/32	151 515/16	167 637/64	232 99/64	70 2¾	48 157/64	140 533/64	- -	73 2,874	64030	45885	UK215+H2315 UK215+HA2315 UK215+HE2315	T215	7,52
UKT216+H2316 UKT216+HA2316 UKT216+HE2316	70 211/16 2¾	32 117/64	21 53/64	111 43/8	70 2¾	41 139/64	121 449/64	26 11/32	165 6½	184 7¼	235 9¼	70 2¾	51 2	140 533/64	- -	78 3,071	69065	50350	UK216+H2316 UK216+HA2316 UK216+HE2316	T216	8,56
UKT217+H2317 UKT217+HA2317 UKT217+HE2317	75 215/16 3	38 1½	29 19/64	124 47/8	73 27/8	48 157/64	157 63/16	30 13/16	173 613/16	198 751/64	260 1015/64	73 27/8	54 21/8	162 63/8	- -	82 3,228	79800	58805	UK217+H2317 UK217+HA2317 UK217+HE2317	T217	11,38

Bussole HA; HE; HS con filettatura in pollici
Inch dimension adapter sleeves HA; HE; HS

UKTX Serie media - Medium duty

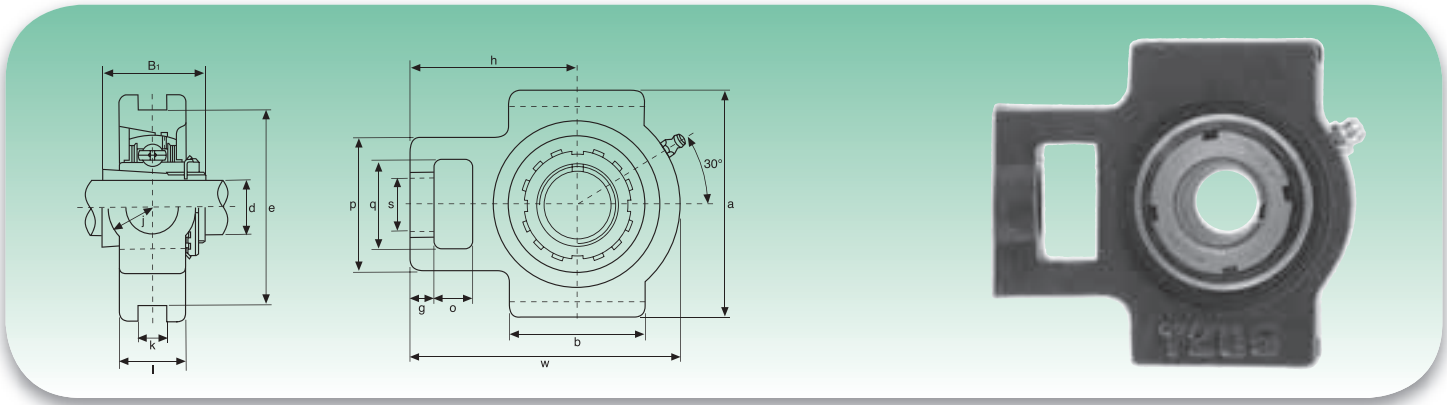

Tipo Type	Dimensioni - Dimensions															Coefficienti di carico (N) Load ratings (N)		Cuscinetto Bearing	Supporto Housing	Peso Weight kg
	d	o	g	p	q	s	b	k	e	a	w	l	j	h	B1	Dinamico C Dynamic C _o	Statico C _o Static C _o			
	mm/inch																			
UKTX05+H2305	20	16	12	56	37	22	57	12	89	102	113	28	37	70	35	18525	10735	UKX05+H2305	TX05	1,3
UCTX05+HE2305	¾	5/8	15/32	27/32	129/64	55/64	2¼	0,472	3½	41/64	429/64	13/32	129/64	2¾	1,378			UKX05+HE2305		
UKTX06+H2306	25	16	15	64	37	22	64	12	89	102	129	30	37	78	38	24415	14630	UKX06+H2306	TX06	1,7
UKTX06+HS2306	7/8																	UKX06+HS2306		
UKTX06+HE2306	1	5/8	19/32	233/64	129/64	55/64	233/64	0,472	3½	41/64	55/64	13/16	129/64	35/64	1,496			UKX06+HE2306		
UKTX07+H2307	30	19	17	83	49	29	83	16	102	114	144	36	49	88	43	27645	16910	UKX07+H2307	TX07	2,6
UKTX07+HS2307	11/8	¾																UKX07+HS2307		
UKTX07+HE2307			21/32	317/64	115/16	19/64	317/64	0,630	41/64	431/64	543/64	113/32	115/16	315/32	1,811			UKX07+HE2307		
UKTX08+H2308	35	19	17	83	49	29	83	16	102	117	144	36	49	87	46	32395	20235	UKX08+H2308	TX08	2,6
UKTX08+HE2308	1¼																	UKX08+HE2308		
UKTX08+HS2308	13/8	¾																UKX08+HS2308		
UKTX08+HE2308			21/32	317/64	115/16	19/64	317/64	0,630	41/64	439/64	543/64	113/32	115/16	327/64	1,811			UKX08+HE2308		
UKTX09+H2309	40	19	18	83	49	29	86	16	102	117	151	38	49	92	50	33345	22135	UKX09+H2309	TX09	2,9
UKTX09+HA2309	17/16																	UKX09+HA2309		
UKTX09+HE2309	1½	¾																UKX09+HE2309		
UKTX09+HS2309	15/8																	UKX09+HS2309		
UKTX10+H2310	45	25	21	102	64	35	95	22	130	146	171	42	64	106	55	41230	27930	UKX10+H2310	TX10	4,4
UKTX10+HS2310	15/8																	UKX10+HS2310		
UKTX10+HA2310	111/16	63/64	13/16	41/64	21/32	13/8	3¾	0,866	51/8	5¾	647/64	121/32	233/64	411/64	2,165			UKX10+HA2310		
UKTX10+HE2310	1¾																	UKX10+HE2310		
UKTX11+H2311	50	32	21	102	64	35	102	22	130	146	194	44	64	119	59	49780	34390	UKX11+H2311	TX11	5,1
UKTX11+HS2311	17/8																	UKX11+HS2311		
UKTX11+HA2311	115/16	117/64	13/16	41/64	21/32	13/8	41/64	0,866	51/8	5¾	741/64	123/32	233/64	411/16	2,323			UKX11+HA2311		
UKTX11+HE2311	2																	UKX11+HE2311		
UKTX12+H2312	55	32	23	111	70	41	121	26	151	167	224	48	70	137	62	54340	38095	UKX12+H2312	TX12	7,3
UKTX12+HS2312	21/8	117/64	29/32	43/8	2¾	139/64	449/64	1,024	515/16	637/64	813/16	157/64	2¾	525/64	2,441			UKX12+HS2312		
UKTX13+H2313	60	32	23	111	70	41	121	26	151	167	224	48	70	137	65	59090	41895	UKX13+H2313	TX13	7,2
UKTX13+HA2313	23/16																	UKX13+HA2313		
UKTX13+HE2313	2¼	117/64	29/32	43/8	2¾	139/64	449/64	1,024	515/16	637/64	813/16	157/64	2¾	525/64	2,559			UKX13+HE2313		
UKTX13+HS2313	23/8																	UKX13+HS2313		
UKTX15+H2315	65	32	23	111	70	41	121	26	151	167	232	48	70	140	73	69065	50350	UKX15+H2315	TX15	8,4
UKTX15+HA2315	27/16																	UKX15+HA2315		
UKTX15+HE2315	23/8	117/64	29/32	43/8	2¾	139/64	449/64	1,024	515/16	637/64	99/64	157/64	2¾	533/64	3,559			UKX15+HE2315		
UKTX16+H2316	70	38	30	124	73	48	157	28	173	198	260	54	73	162	78	79800	58805	UKX16+H2316	TX16	11,8
UKTX16+HA2316	211/16																	UKX16+HA2316		
UKTX16+HE2316	2¾	1½	13/16	47/8	27/8	157/64	63/16	1,102	613/16	751/64	1015/64	21/8	27/8	63/8	3,071			UKX16+HE2316		
UKTX17+H2317	75	38	30	124	73	48	157	28	173	198	260	54	73	162	82	91295	67925	UKX17+H2317	TX17	11,4
UKTX17+HA2317	215/16																	UKX17+HA2317		
UKTX17+HS2317	3	1½	13/16	47/8	27/8	157/64	63/16	1,102	613/16	751/64	1015/64	21/8	27/8	63/8	3,228			UKX17+HE2317		

Bussole HA; HE; HS con filettatura in pollici
Inch dimension adapter sleeves HA; HE; HS

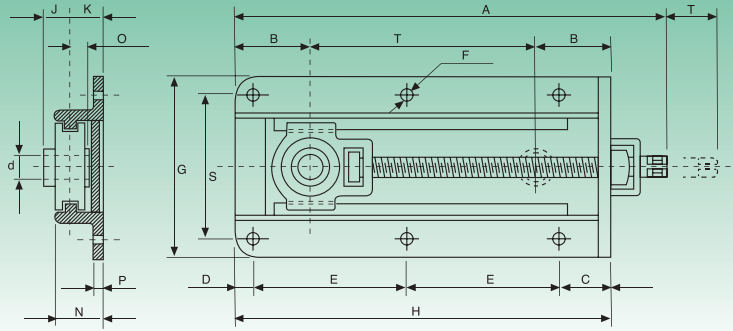
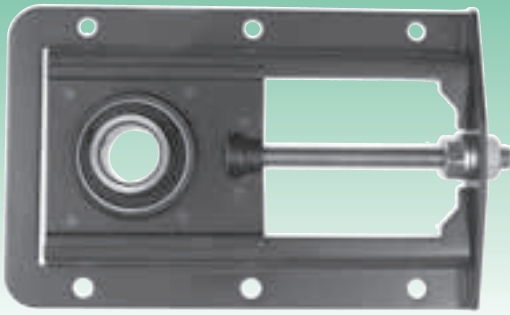
PUCT2 Serie normale - Standard duty

Tipo Type	Dimensioni - Dimensions																Peso Weight kg
	d	A	B	C	D	E	F	G	H	J	K	N	O	P	S	T	
	mm/inch																
PUCT204	20	380	80	60	20	120	11	194	320	18,3	28	45	12,7	5	154	160	4,4
PUCT205	25	380	80	60	20	120	11	194	320	19,7	28	45	14,3	5	154	160	4,4
PUCT206	30	480	95	64	20	158	11	206	400	22,2	32	45	15,9	5	166	210	6,2
PUCT207	35	480	95	64	20	158	11	206	400	25,4	32	45	17,5	5	166	210	6,5
PUCT208	40	600	105	58	22	220	13	234	520	30,2	32	50	19	5	190	310	10,9
PUCT209	45	600	105	58	22	220	13	234	520	30,2	32	50	19	5	190	310	10,8
PUCT210	50	600	105	58	22	220	13	234	520	32,6	32	50	19	5	190	310	11
PUCT211	55	680	125	55	25	250	15	284	580	33,4	45	70	22,2	6	240	330	20,4
PUCT212	60	680	125	55	25	250	15	284	580	39,7	45	70	25,4	6	240	330	21,3
PUCT213	65	790	155	66	22	306	18	303	700	39,7	51	75	25,4	6	258	390	28,3
PUCT214	70	790	155	66	22	306	18	303	700	44,4	51	75	30,2	6	258	390	28,1
PUCT215	75	790	155	66	22	306	18	303	700	44,5	51	75	33,3	6	258	390	28,7
PUCT216	80	890	165	75	25	230*	18	336	790	49,3	62	90	33,3	10	286	460	38,2
PUCT217	85	920	180	75	25	240*	18	361	820	51,6	62	100	34,1	10	311	460	44

* Piastre con quattro fori di fissaggio
Stretch skid with four fixing hole

PIASTRA CON TENDITORE PER UCT - STRETCH SKID FOR UCT
PUCTX2 Serie media - Medium duty

Tipo Type	Dimensioni - Dimensions																Peso Weight kg
	d	A	B	C	D	E	F	G	H	J	K	N	O	P	S	T	
	mm/inch																
PUCTX-05	25	480	95	64	20	158	11	206	400	22,2	32	45	15,9	5	166	210	6,8
PUCTX-06	30	480	95	64	20	158	11	206	400	25,4	32	45	17,5	5	166	210	7,0
PUCTX-07	35	600	105	58	22	220	13	234	520	30,2	32	50	19,0	5	190	310	11,1
PUCTX-08	40	600	105	58	22	220	13	234	520	30,2	32	50	19,0	5	190	310	11,1
PUCTX-09	45	600	105	58	22	220	13	234	520	32,6	32	50	19,0	5	190	310	11,3
PUCTX-10	50	680	125	55	25	250	15	284	580	33,4	45	70	22,2	6	240	330	20,1
PUCTX-11	55	680	125	55	25	250	15	284	580	39,7	45	70	25,4	6	240	330	20,9
PUCTX-12	60	790	155	66	22	306	18	303	700	39,7	51	75	25,4	6	258	390	28,1
PUCTX-13	65	790	155	66	22	306	18	303	700	44,4	51	75	30,2	6	258	390	28,3
PUCTX-14	70	790	155	66	22	306	18	303	700	44,5	51	75	33,3	6	258	390	28,6
PUCTX-15	75	890	165	75	25	230*	18	336	790	49,3	62	90	33,3	10	286	460	38,1
PUCTX-16	80	920	180	75	25	240*	18	365	820	51,6	62	100	34,1	10	315	460	49,5
PUCTX-17	85	920	180	75	25	240*	18	365	820	56,3	62	100	39,7	10	315	460	49,4

* Piastre con quattro fori di fissaggio
Stretch skid with four fixing hole

UCC2 Serie normale - Standard duty

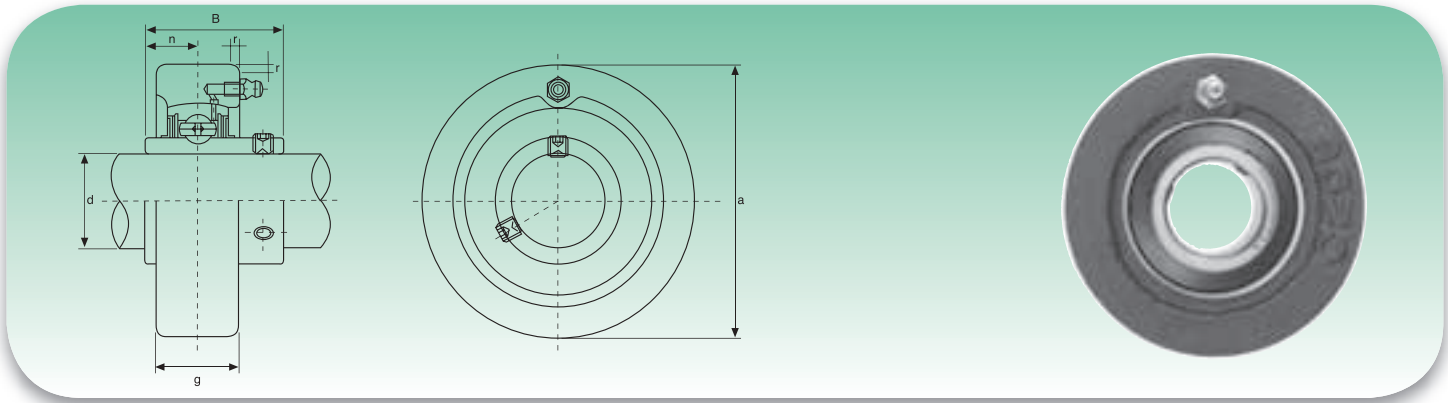

Tipo Type	Dimensioni - Dimensions						Coefficienti di carico (N) Load ratings (N)		Cuscinetto Bearing	Supporto Housing	Peso Weight
	d	a	g	r	B	n	Dinamico C Dynamic C	Statico C ₀ Static C ₀			
	mm/inch										
UCC201	12	72	20	2	31	12,7	12160	6318	UC201	C204	0,52
UCC201-8	½	2,8346	25/32	0,079	1,2205	0,500			UC201-8		0,51
UCC202	15	72	20	2	31	12,7	12160	6318	UC202	C204	0,51
UCC202-9	9/16	2,8346	25/32	0,079	1,2205	0,500			UC202-9		0,51
UCC202-10	5/8						UC202-10	0,51			
UCC203	17	72	20	2	31	12,7	12160	6318	UC203	C204	0,50
UCC203-11	11/16	2,8346	25/32	0,079	1,2205	0,500			UC203-11		0,49
UCC204	20	72	20	2	31	12,7	12160	6318	UC204	C204	0,48
UCC204-12	¾	2,8346	25/32	0,079	1,2205	0,500			UC204-12		0,48
UCC205	25	80	22	2	34,1	14,3	13300	7457	UC205	C205	0,63
UCC205-13	13/16	3,1496	55/64	0,079	1,3425	0,563			UC205-13		0,67
UCC205-14	7/8								UC205-14		0,66
UCC205-15	15/16								UC205-15		0,64
UCC205-16	1								UC205-16		0,63
UCC206	30						85	27	2	38,1	15,9
UCC206-17	11/16	3,3465	11/16	0,079	1,5000	0,626	UC206-17	0,83			
UCC206-18	11/8						UC206-18	0,82			
UCC206-19	13/16						UC206-19	0,80			
UCC206-20	1¼						UC206-20	0,79			
UCC207	35						90	28	2	42,9	17,5
UCC207-20	1¼	3,5433	17/64	0,079	1,6890	0,689	UC207-20	0,99			
UCC207-21	15/16						UC207-21	0,96			
UCC207-22	13/8						UC207-22	0,93			
UCC207-23	17/16						UC207-23	0,90			
UCC208	40						100	30	2,5	49,2	19
UCC208-24	1½	3,9370	13/16	0,098	1,9370	0,748	UC208-24	1,26			
UCC208-25	19/16						UC208-25	1,23			
UCC209	45						110	31	2,5	49,2	19
UCC209-26	15/8	4,3307	17/32	0,098	1,9370	0,748	UC209-26	1,59			
UCC209-27	111/16						UC209-27	1,55			
UCC209-28	1¾						UC209-28	1,51			
UCC210	50						120	33	2,5	51,6	19
UCC210-29	113/16	4,7244	119/64	0,098	2,0315	0,748	UC210-29	2,02			
UCC210-30	17/8						UC210-30	1,97			
UCC210-31	115/16						UC210-31	1,92			
UCC210-32	2						UC210-32	1,88			
UCC211	55						125	35	2,5	55,6	22,2
UCC211-32	2	4,9213	13/8	0,098	2,1890	0,874	UC211-32	2,33			
UCC211-33	21/16						UC211-33	2,27			
UCC211-34	21/8						UC211-34	2,22			
UCC211-35	23/16						UC211-35	2,16			
UCC212	60						130	38	2,5	65,1	25,4
UCC212-36	2¼	5,1181	1½	0,098	2,5630	1,000	UC212-36	2,65			
UCC212-37	25/16						UC212-37	2,57			
UCC212-38	23/8						UC212-38	2,50			
UCC212-39	27/16						UC212-39	2,43			
UCC213	65						140	40	3	65,1	25,4
UCC213-40	2½	5,5118	137/64	0,118	2,5630	1,000	UC213-40	3,07			
UCC213-41	29/16						UC213-41	2,98			

Disponibile in acciaio inox Supporto: AISI 304 - Cuscinetto: AISI 440C o 420C - Available stainless steel Housing: AISI 304 - Bearing: AISI 440C or 420C
 Disponibile su richiesta con cuscinetto SA (SACC) - Available under request with SA bearing (SACC)

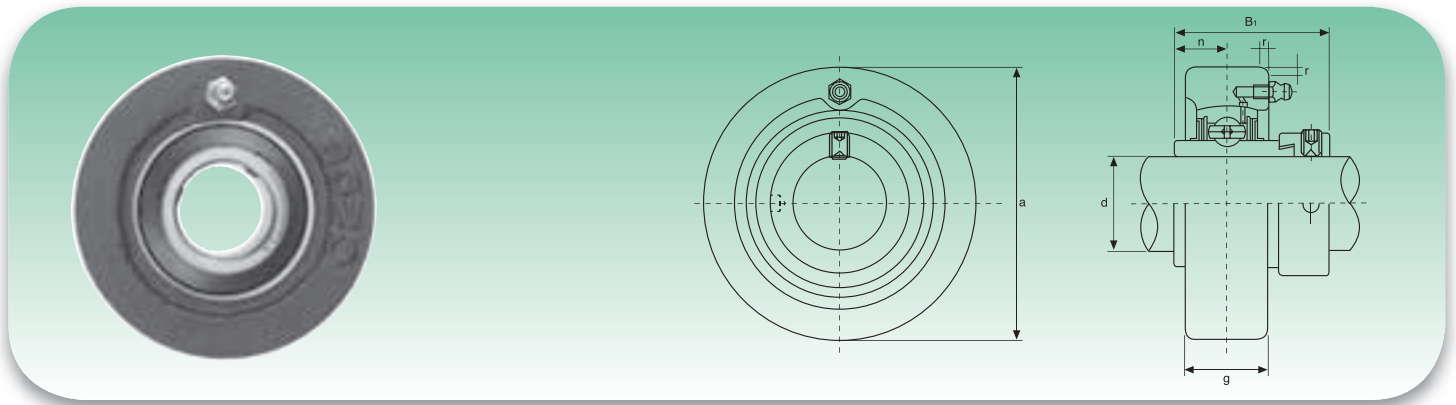
HCC2 Serie normale - Normal duty

Tipo Type	Dimensioni - Dimensions						Coefficienti di carico (N) Load ratings (N)		Cuscinetto Bearing	Supporto Housing	Peso Weight					
	d	a	g	r	B ₁	n	Dinamico C Dynamic C	Statico C ₀ Static C ₀								
	mm/inch										kg					
HCC204	20	72	20	2	43,7	17,1	12160	6318	HC204	C204	0,55					
HCC204-12	¾	2,8346	25/32	0,079	1,720	0,673			0,55							
HCC205	25	80	22	2	44,4	17,5	13300	7457	HC205	C205	0,70					
HCC205-13	13/16	3,1496	55/64	0,079	1,748	0,689			0,75							
HCC205-14	7/8								0,74							
HCC205-15	15/16								0,72							
HCC205-16	1								0,70							
HCC206	30						85	27	2	48,4	18,3	18525	10735	HC206	C206	0,93
HCC206-17	11/16	3,3465	11/16	0,079	1,906	0,720	0,98									
HCC206-18	11/8						0,95									
HCC206-19	13/16						0,93									
HCC206-20	1¼						0,90									
HCC207	35						90	28	2	51,1	18,8			24415		14630
HCC207-20	1¼						3,5433	17/64	0,079	2,012	0,740	1,12				
HCC207-21	15/16	1,08														
HCC207-22	13/8	1,05														
HCC207-23	17/16	1,02														
HCC208	40	100	30	2,5	56,3	21,4						27645	16910	HC208	C208	1,37
HCC208-24	1½	3,9370	13/16	0,098	2,217	0,843	1,42									
HCC208-25	19/16						1,38									
HCC209	45						110	31	2,5	56,3	21,4	32395	20235	HCF209	C209	1,66
HCC209-26	15/8	4,3307	17/32	0,098	2,217	0,843	1,77									
HCC209-27	111/16						1,72									
HCC209-28	1¾						1,68									
HCC210	50						120	33	2,5	62,7	24,6	33345	22135	HCF210	C210	2,09
HCC210-29	113/16	4,7244	119/64	0,098	2,469	0,969	2,24									
HCC210-30	17/8						2,18									
HCC210-31	115/16						2,12									
HCC210-32	2						2,06									
HCC211	55						125	35	2,5	71,4	27,8	41230	27930	HCF211	C211	2,39
HCC211-32	2	4,9213	13/8	0,098	2,811	1,094	2,59									
HCC211-33	22/16						2,51									
HCC211-34	21/8						2,44									
HCC211-35	23/16						2,36									
HCC212	60						130	38	2,5	77,8	31	49780	34390	HC212	C212	2,86
HCC212-36	2¼	5,1181	1½	0,098	3,063	1,220	3,02									
HCC212-37	25/16						2,93									
HCC212-38	23/8						2,88									
HCC212-39	27/16						2,75									

UCC3 Serie media - Medium duty

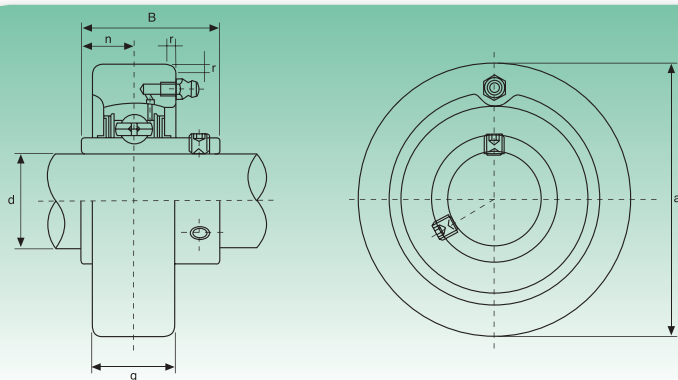

Tipo Type	Dimensioni - Dimensions						Coefficients di carico (N) Load ratings (N)		Cuscinetto Bearing	Supporto Housing	Peso Weight kg
	d	a	g	r	B	n	Dinamico C Dynamic C	Statico C ₀ Static C ₀			
mm/inch											
UCC305 UCC305-13 UCC305-14 UCC305-15 UCC305-16	25 13/16 7/8 15/16 1	90 3,5433	26 11/32	2,5 0,098	38 1,4961	15 0,591	20140	10355	UC305 UC305-13 UC305-14 UC305-15 UC305-16	C305	1,10 1,15 1,13 1,11 1,10
UCC306 UCC306-17 UCC306-18 UCC306-19	30 11/16 11/8 13/16	100 3,9370	28 17/64	2,5 0,098	43 1,6929	17 0,669	25365	14250	UC306 UC306-17 UC306-18 UC306-19	C306	1,40 1,45 1,42 1,40
UCC307 UCC307-20 UCC307-21 UCC307-22 UCC307-23	35 1 1/4 15/16 13/8 17/16	110 4,3307	32 11/64	3 0,118	48 1,8897	19 0,748	31730	18335	UC307 UC307-20 UC307-21 UC307-22 UC307-23	C307	1,80 1,86 1,83 1,80 1,78
UCC308 UCC308-24 UCC308-25	40 1 1/2 19/16	120 4,7244	34 111/32	3 0,118	52 2,0472	19 0,748	38665	22800	UC308 UC308-24 UC308-25	C308	2,20 2,25 2,21
UCC309 UCC309-26 UCC309-27 UCC309-28	45 15/8 111/16 1 3/4	130 2,1181	38 1 1/2	3,5 0,138	57 2,441	22 0,866	46455	28025	UC309 UC309-26 UC309-27 UC309-28	C309	2,70 2,81 2,77 2,72
UCC310 UCC310-29 UCC310-30 UCC310-31	50 113/16 17/8 115/16	140 5,118	40 137/64	3,5 0,138	61 2,4015	22 0,866	58900	36385	UC310 UC310-29 UC310-30 UC310-31	C310	3,30 3,62 3,39 3,33
UCC311 UCC311-32 UCC311-33 UCC311-34 UCC311-35	55 2 21/16 21/8 23/16	150 5,9055	44 147/64	3,5 0,138	66 2,5984	25 0,984	68020	42750	UC311 UC311-32 UC311-33 UC311-34 UC311-35	C311	3,90 1,08 4,01 3,95 3,87
UCC312 UCC312-36 UCC312-37 UCC312-38 UCC312-39	60 2 1/4 25/16 23/8 27/16	160 6,2992	46 113/16	3,5 0,138	71 2,7953	26 1,024	77805	49590	UC312 UC312-36 UC312-37 UC312-38 UC312-39	C312	4,80 4,95 4,87 4,78 4,70
UCC313 UCC313-40 UCC313-41	65 2 1/2 29/16	170 6,6929	50 131/32	3,5 0,138	75 2,9528	30 1,181	88065	56905	UC313 UC313-40 UC313-41	C313	5,80 5,89 5,89
UCC314 UCC314-42 UCC314-43 UCC314-44	70 25/8 211/16 2 3/4	180 7,0866	52 23/64	4 0,157	78 3,0709	33 1,299	98800	64790	UC314 UC314-42 UC314-43 UC314-44	C314	6,60 6,82 6,71 6,61
UCC315 UCC315-45 UCC315-46 UCC315-47 UCC315-48	75 213/16 27/8 215/16 3	190 7,4803	55 211/64	4 0,157	82 3,2288	32 1,260	107350	73340	UC315 UC315-45 UC315-46 UC315-47 UC315-48	C315	7,80 8,07 7,93 7,84 7,71
UCC316 UCC316-49 UCC316-50 UCC316-51	80 31/16 31/8 33/16	200 7,8740	60 223/64	4 0,157	86 3,3858	34 1,339	116850	82365	UC316 UC316-49 UC316-50 UC316-51	C316	9,05 9,22 9,08 8,99
UCC317 UCC317-52 UCC317-53 UCC317-54	85 3 1/4 35/16 37/16	215 8,4646	64 234/64	4 0,157	96 3,7795	40 1,575	126350	91960	UC317 UC317-52 UC317-53 UC317-55	C317	10,97 11,19 11,06 10,74
UCC318 UCC318-55 UCC318-56	90 37/16 3 1/2	225 8,8583	66 216/32	4 0,157	96 3,7795	40 1,575	135850	101650	UC318 UC318-55 UC318-56	C318	11,96 12,25 12,07
UCC319 UCC319-58 UCC319-59 UCC319-60	95 35/8 311/16 3 3/4	240 9,4488	66 253/64	4 0,157	103 4,0551	41 1,614	145350	113050	UC319 UC319-58 UC319-59 UC319-60	C319	15,00 15,33 15,15 14,96
UCC320 UCC320-64	100 4	260 10,2362	75 261/64	4 0,157	108 4,2519	42 1,645	164350	133950	UC320 UC320-64	C320	19,6 19,4
UCC322	110	320 11,8110	90 32/32	5 0,197	126 4,6063	46 1,811	194750	171000	UC322	C322	29,2
UCC324	120	370 12,5984	290 335/64	5 0,197	40 4,9606	51 2,008	196650	175750	UC324	C324	35,9
UCC326	130	340 13,3858	100 315/16	5 0,197	135 5,3150	54 2,126	217550	203300	UC326	C326	43,0
UCC328	140	360 14,1732	100 315/16	5 0,197	145 5,7086	59 3,323	240350	233700	UC328	C328	52,9

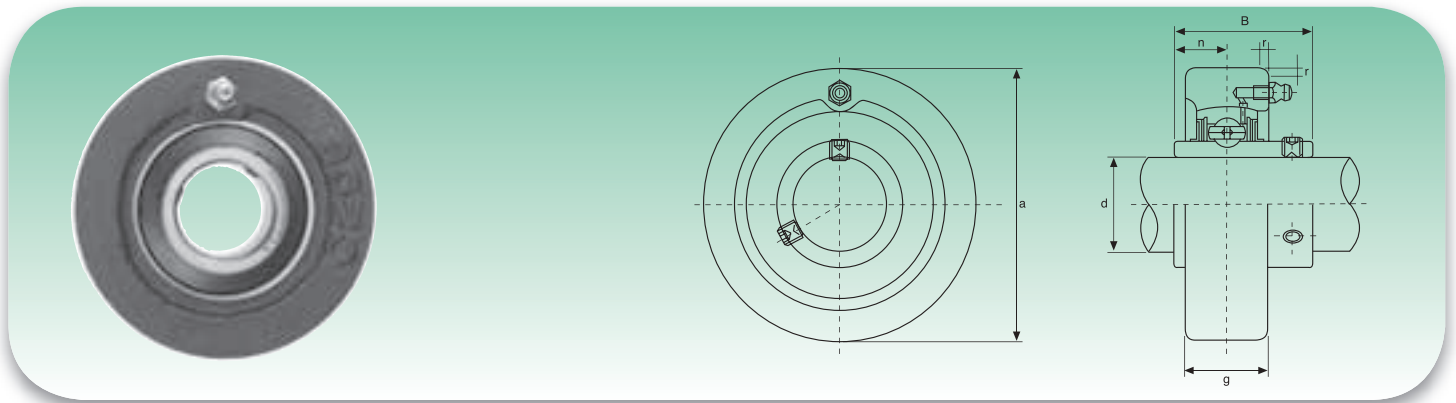

Tipo Type	Dimensioni - Dimensions						Coefficienti di carico (N) Load ratings (N)		Cuscinetto Bearing	Supporto Housing	Peso Weight kg
	d	a	g	r	B	n	Dinamico C Dynamic C	Statico C ₀ Static C ₀			
	mm/inch										
UCCX05	25	90	27	2	38,1	15,9			UCX05		
UCCX05-13	13/16								UCX05-13		
UCCX05-14	7/8	3,5433	11/16	0,079	1,5000	0,626	18525	10735	UCX05-14	CX05	1,1
UCCX05-15	15/16								UCX05-15		
UCCX05-16	1								UCX05-16		
UCCX06	30	100	30	2,5	42,9	17,5			UCX06		
UCCX06-17	11/16								UCX06-17		
UCCX06-18	11/8	3,9370	13/16	0,098	1,6890	0,689	24415	14630	UCX06-18	CX06	1,6
UCCX06-19	13/16								UCX06-19		
UCCX06-20	1¼								UCX06-20		
UCCX07	35	110	34	2,5	49,2	19			UCX07		
UCCX07-21	15/16								UCX07-21		
UCCX07-22	13/8	4,3307	111/32	0,098	1,9370	0,748	27645	16910	UCX07-22	CX07	2,0
UCCX07-23	17/16								UCX07-23		
UCCX08	40	120	38	2,5	49,2	19			UCX08		
UCCX08-24	1½	4,7244	1½	0,098	1,9370	0,748	32395	20235	UCX08-24	CX08	2,5
UCCX08-25	19/16								UCX08-25		
UCCX09	45	120	38	2,5	51,6	19			UCX09		
UCCX09-26	15/8								UCX09-26		
UCCX09-27	111/16	4,7244	1½	0,098	2,0315	0,748	33345	22135	UCX09-27	CX09	2,4
UCCX09-28	1¾								UCX09-28		
UCCX09-29	113/16								UCX09-29		
UCCX10	50	130	40	2,5	55,6	22,2			UCX10		
UCCX10-30	17/8								UCX10-30		
UCCX10-31	115/16	5,1181	137/64	0,098	2,1890	0,874	41230	27930	UCX10-31	CX10	3,0
UCCX10-32	2								UCX10-32		
UCCX11	55	150	42	3	65,1	25,4			UCX11		
UCCX11-33	21/16								UCX11-33		
UCCX11-34	21/8	5,9055	121/32	0,118	2,5630	1,000	49780	34390	UCX11-34	CX11	4,4
UCCX11-35	23/16								UCX11-35		
UCCX11-36	2¼								UCX11-36		
UCCX11-37	25/16								UCX11-37		
UCCX12	60	160	44	3	65,1	25,4			UCX12		
UCCX12-38	23/8	6,2992	147/64	0,118	2,5630	1,000	54340	38095	UCX12-38	CX12	5,0
UCCX12-39	27/16								UCX12-39		

UKC2 Serie normale - Standard duty

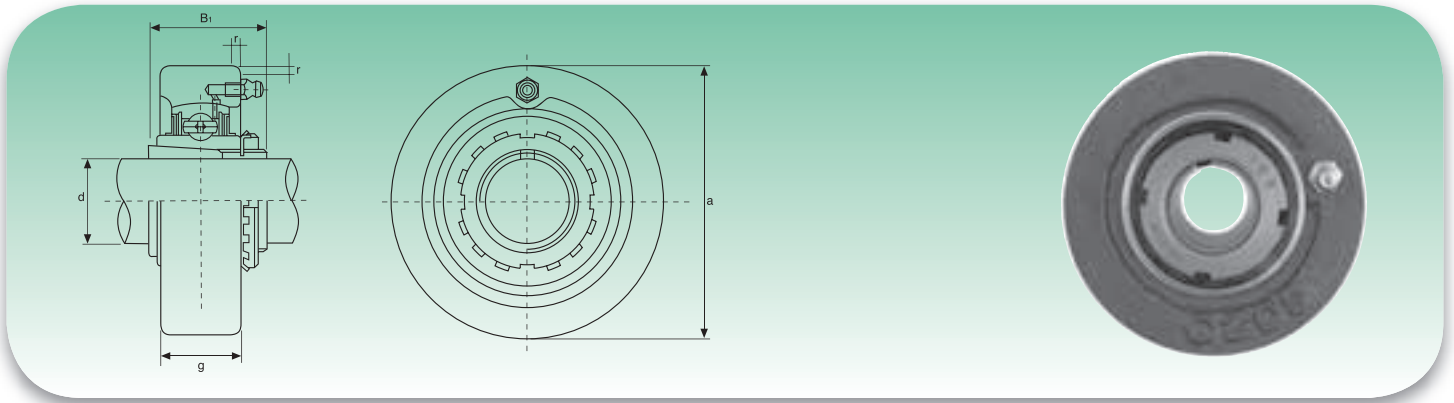

Tipo Type	Dimensioni - Dimensions					Coefficients di carico (N) Load ratings (N)		Cuscinetto Bearing	Supporto Housing	Peso Weight kg
	d	a	g	r	B ₁	Dinamico C Dynamic C	Statico C ₀ Static C ₀			
	mm/inch									
UKC205+H2305	20	80	22	2	35	13300	7457	UK205+H2305	C205	0,68
UKC205+HE2305	¾	3,1496	55/64	0,079	1,378			UK205+HE2305		
UKC206+H2306	25	85	27	2	38	18525	10735	UK206+H2306	C206	0,84
UKC206+HS2306	7/8	3,3465	11/16	0,079	1,496			UK206+HS2306		
UKC206+HE2306	1							UK206+HE2306		
UKC207+H2307	30	90	28	2	43	24415	14630	UK207+H2307	C207	1,02
UKC207+HS2307	11/8	3,5433	17/64	0,079	1,693			UK207+HS2307		
UKC208+H2308	35	100	30	2,5	46	27645	16910	UK208+H2308	C208	1,32
UKC208+HE2308	1¼	3,9370	13/16	0,098	1,811			UK208+HE2308		
UKC208+HS2308	13/8							UK208+HS2308		
UKC209+H2309	40	110	31	2,5	50	32395	20235	UK209+H2309	C209	1,64
UKC209+HA2309	17/16	4,3307	17/32	0,098	1,969			UK209+HA2309		
UKC209+HE2309	1½							UK209+HE2309		
UKC209+HS2309	15/8							UK209+HS2309		
UKC210+H2310	45	120	33	2,5	55	33345	22135	UK210+H2310	C210	2,07
UKC210+HS2310	15/8	4,7244	119/64	0,098	2,165			UK210+HS2310		
UKC210+HA2310	111/16							UK210+HA2310		
UKC210+HE2310	1¾							UK210+HE2310		
UKC211+H2311	50	125	35	2,5	59	41230	27930	UK211+H2311	C211	2,33
UKC211+HS2311	17/8	4,9213	13/6	0,098	2,323			UK211+HS2311		
UKC211+HA2311	115/16							UK211+HA2311		
UKC211+HE2311	2							UK211+HE2311		
UKC212+H2312	55	130	38	2,5	62	49780	34390	UK212+H2312	C212	2,57
UKC212+HS2312	21/8	5,1181	1½	0,098	2,441			UK212+HS2312		
UKC213+H2313	60	140	40	3	65	54340	38095	UK213+H2313	C213	2,89
UKC213+HA2313	23/16	5,5118	137/64	0,118	2,559			UK213+HA2313		
UKC213+HE2313	2¼							UK213+HE2313		
UKC213+HS2313	23/8							UK213+HS2313		

Bussole HA; HE; HS con filettatura in pollici
Inch dimension adapter sleeves HA; HE; HS

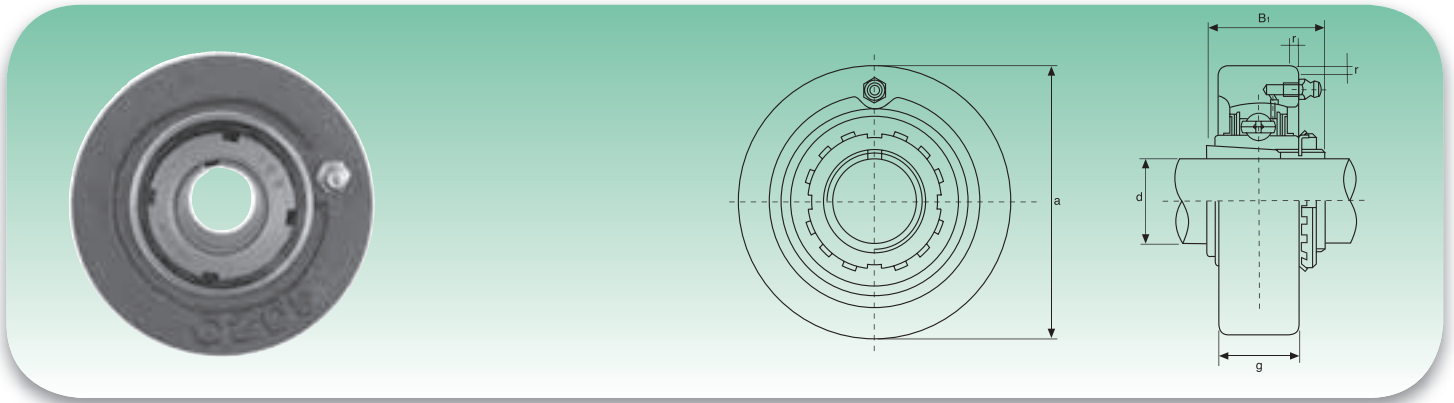
UKCX Serie media - Medium duty

Tipo Type	Dimensioni - Dimensions					Coefficienti di carico (N) Load ratings (N)		Cuscinetto Bearing	Supporto Housing	Peso Weight kg
	d	a	g	r	B ₁	Dinamico C Dynamic C	Statico C ₀ Static C ₀			
	mm/inch									
UKCX05+H2305	20	90	27	2	35	18525	10735	UKX05+H2305	CX05	0,99
UKCX05+HE2305	¾	3,5433	11/16	0,079	1,378			UKX05+HE2305		
UKCX06+H2306	25	100	30	2,5	38	24415	14630	UKX06+H2306	CX06	1,3
UKCX06+HS2306	7/8	3,9370	13/16	0,098	1,496			UKX06+HS2306		
UKCX06+HE2306	1							UKX06+HE2306		
UKCX07+H2307	30	110	34	2,5	43	27645	16910	UKX07+H2307	CX07	1,7
UKCX07+HS2307	11/8	4,3307	111/32	0,098	1,693			UKX07+HS2307		
UKCX08+H2308	35	120	38	2,5	46	32395	20235	UKX08+H2308	CX08	2,3
UKCX08+HE2308	1¼	4,7244	1½	0,098	1,811			UKX08+HE2308		
UKCX08+HS2308	13/8							UKX08+HS2308		
UKCX09+H2309	40	120	38	2,5	50	33345	22135	UKX09+H2309	CX09	2,3
UKCX09+HA2309	17/16	4,7244	1½	0,098	1,969			UKX09+HA2309		
UKCX09+HE2309	1½							UKX09+HE2309		
UKCX09+HS2309	15/8							UKX09+HS2309		
UKCX10+H2310	45	130	40	2,5	55	41230	27930	UKX10+H2310	CX10	2,8
UKCX10+HS2310	15/8	5,1181	137/64	0,098	2,165			UKX10+HS2310		
UKCX10+HA2310	111/16							UKX10+HA2310		
UKCX10+HE2310	1¾							UKX10+HE2310		
UKCX11+H2311	50	150	42	3	59	49780	34390	UKX11+H2311	CX11	3,8
UKCX11+HS2311	117/8	5,9055	121/32	0,118	2,323			UKX11+HS2311		
UKCX11+HA2311	115/16							UKX11+HA2311		
UKCX11+HE2311	2							UKX11+HE2311		
UKCX12+H2312	55	130	38	2,5	62	54340	38095	UKX12+H2312	CX12	4,4
UKCX12+HS2312	21/8	6,2992	123/32	0,118	2,441			UKX12+HS2312		

Bussole HA; HE; HS con filettatura in pollici
Inch dimension adapter sleeves HA; HE; HS

UCPH2 Serie normale - Standard duty

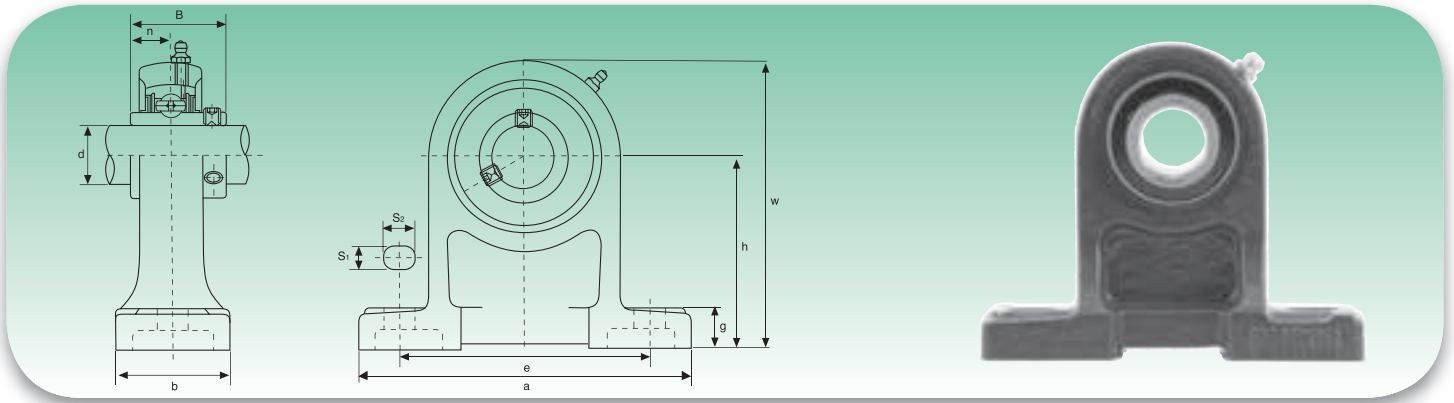

Tipo Type	Dimensioni - Dimensions											Bull. fess. Bolt Size	Coefficients di carico (N) Load ratings (N)		Cuscinetto Bearing	Supporto Housing	Peso Weight	
	d	h	a	e	b	S ₁	S ₂	g	w	B	n		Dinamico C Dynamic C	Statico C ₀ Static C ₀				kg
	mm/inch												mm/inch					
UCPH201 UCPH201-8	12 ½	70 2¾	127 5	95 3¾	40 19/16	13 ½	19 ¾	15 19/32	101 363/64	31 1,2205	12,7 0,500	M10 3/8	12160	6318	UC201 UC201-8	PH203	0,81 0,80	
UCPH202 UCPH202-9 UCPH202-10	15 9/16 5/8	70 2¾	127 5	95 3¾	40 19/16	13 ½	19 ¾	15 19/32	101 363/64	31 1,2205	12,7 0,500	M10 3/8	12160	6318	UC202 UC202-9 UC202-10	PH203	0,80 0,80 0,80	
UCPH203 UCPH203-11	17 11/16	70 2¾	127 5	95 3¾	40 19/16	13 ½	19 ¾	15 19/32	101 363/64	31 1,2205	12,7 0,500	M10 3/8	12160	6318	UC203 UC203-11	PH203	0,79 0,78	
UCPH204 UCPH204-12	20 ¾	70 2¾	127 5	95 3¾	40 19/16	13 ½	19 ¾	15 19/32	101 363/64	31 1,2205	12,7 0,500	M10 3/8	12160	6318	UC204 UC204-12	PH204	0,77 0,77	
UCPH205 UCPH205-13 UCPH205-14 UCPH205-15 UCPH205-16	25 13/16 7/8 15/16 1	80 35/32	140 5½	105 41/8	50 131/32	13 ½	19 ¾	16 5/8	114 431/64	34,1 1,3425	14,3 0,563	M10 3/8	13300	7457	UC205 UC205-13 UC205-14 UC205-15 UC205-16	PH205	1,01 1,05 1,04 1,02 1,01	
UCPH206 UCPH206-17 UCPH206-18 UCPH206-19 UCPH206-20	30 11/16 11/8 13/16 1¼	90 335/64	161 611/32	121 4¾	50 131/32	17 43/64	21 53/64	17 43/64	130 51/8	38,1 1,5000	15,9 0,626	M14 ½	18525	10735	UC206 UC206-17 UC206-18 UC206-19 UC206-20	PH206	1,47 1,50 1,49 1,47 1,46	
UCPH207 UCPH207-20 UCPH207-21 UCPH207-22 UCPH207-23	35 1¼ 15/16 13/8 17/16	95 347/64	166 617/32	127 5	60 223/64	17 43/64	21 53/64	18 45/64	140 533/64	42,9 1,6890	17,5 0,689	M14 ½	24415	14630	UC207 UC207-20 UC207-21 UC207-22 UC207-23	PH207	1,91 1,97 1,94 1,91 1,88	
UCPH208 UCPH208-24 UCPH208-25	40 1½ 19/16	100 315/16	178 71/64	137 513/32	70 2¾	17 43/64	21 53/64	19 ¾	150 529/32	49,2 1,9370	19 0,748	M14 ½	27645	16910	UC208 UC208-24 UC208-25	PH208	2,52 2,56 2,53	
UCPH209 UCPH209-26 UCPH209-27 UCPH209-28	45 15/8 111/16 1¾	105 49/64	189 77/16	146 5¾	70 2¾	17 43/64	21 53/64	20 25/32	158 67/32	49,2 1,9370	19 0,748	M14 ½	32395	20235	UC209 UC209-26 UC209-27 UC209-28	PH209	2,72 2,82 2,78 2,74	
UCPH210 UCPH210-29 UCPH210-30 UCPH210-31 UCPH210-32	50 113/16 17/8 115/16 2	110 421/64	205 85/64	159 6¼	70 2¾	20 25/32	23 29/32	21 53/64	165 6½	51,6 2,0315	19 0,748	M16 5/8	33345	22135	UC210 UC210-29 UC210-30 UC210-31 UC210-32	PH210	3,10 3,22 3,17 3,12 3,08	
UCPH211 UCPH211-32 UCPH211-33 UCPH211-34 UCPH211-35	55 2 21/16 21/8 23/16	120 423/32	219 85/8	171 647/64	75 261/64	20 25/32	23 29/32	22 55/64	181 71/8	55,6 2,1890	22,2 0,874	M16 5/8	41230	27930	UC211 UC211-32 UC211-33 UC211-34 UC211-35	PH211	- - - -	
UCPH212 UCPH212-36 UCPH212-37 UCPH212-38 UCPH212-39	60 2¼ 25/16 23/8 27/16	130 51/8	241 9½	184 7¼	85 311/32	20 25/32	23 29/32	25 63/64	197 7¾	65,1 2,5630	25,4 1,000	M16 5/8	49780	34390	UC212 UC212-36 UC212-37 UC212-38 UC212-39	PH212	- - - -	
UCPH213 UCPH213-40 UCPH213-41	65 2½ 29/16	140 533/64	265 107/16	203 8	95 3¾	25 63/64	28 13/32	27 11/16	212 811/32	65,1 2,5630	25,4 1,000	M20 ¾	54340	38095	UC213 UC213-40 UC213-41	PH213	- - -	
UCPH214 UCPH214-42 UCPH214-43 UCPH214-44	70 25/8 211/16 2¾	150 529/32	266 1015/32	210 817/64	105 59/64	25 63/64	28 13/32	28 17/64	225 855/64	74,6 2,9370	30,2 1,189	M20 ¾	59090	41895	UC214 UC214-42 UC214-43 UC214-44	PH214	- - - -	
UCPH215 UCPH215-45 UCPH215-46 UCPH215-47 UCPH215-48	75 213/16 27/8 215/16 3	160 519/64	275 1053/64	217 835/64	115 417/32	25 63/64	28 13/32	29 19/64	238 93/8	77,8 3,0630	33,3 1,311	M20 ¾	64030	45885	UC215 UC215-45 UC215-46 UC215-47 UC215-48	PH215	- - - - -	
UCPH216 UCPH216-49 UCPH216-50 UCPH216-51	80 31/16 31/8 33/16	170 611/16	292 11½	232 91/8	125 459/64	25 63/64	28 13/32	30 13/16	253 961/64	82,6 3,2520	33,3 1,311	M20 ¾	69065	50350	UC216 UC216-49 UC216-50 UC216-51	PH216	- - - -	

Disponibile in acciaio inox Supporto: AISI 304 - Cuscinetto: AISI 440C o 420C - Available stainless steel Housing: AISI 304 - Bearing: AISI 440C or 420C
Disponibile su richiesta con cuscinetto SA (SAPH) - Available under request with SA bearing (SAPH)

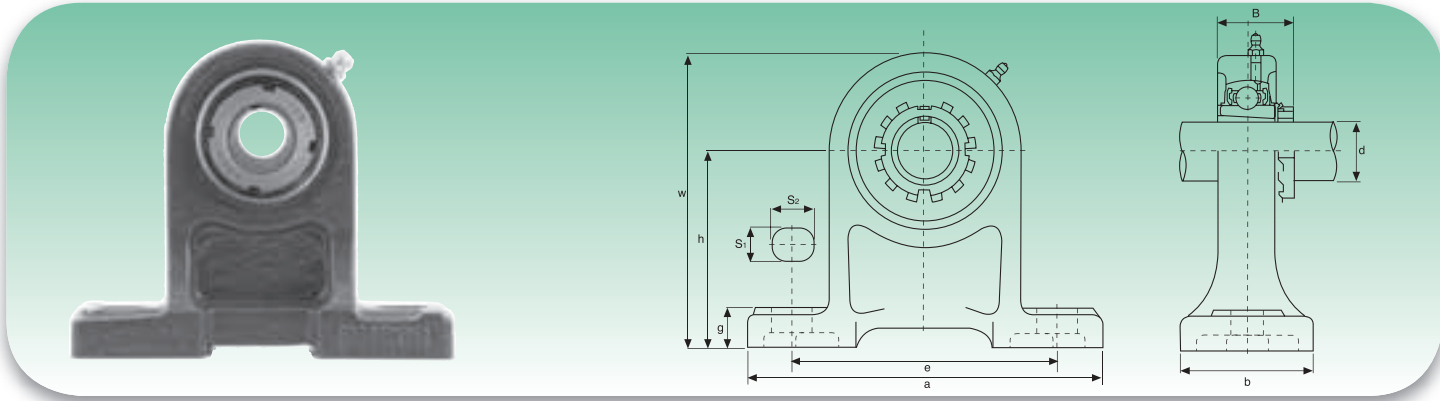
UKPH2 Serie normale - Standard duty

Tipo Type	Dimensioni - Dimensions										Bull. fiss. Bolt Size	Coefficienti di carico (N) Load ratings (N)		Cuscinetto Bearing	Supporto Housing	Peso Weight kg
	d	h	a	e	b	S ₁	S ₂	g	w	B ₁		Dinamico C Dynamic C	Statico C ₀ Static C ₀			
	mm/inch											mm/inch				
UKPH205+H2305	20	80	140	105	50	13	19	16	114	34,1	M10	13300	7457	UK205+H2305	PH205	1,24
UKPH205+HE2305	¾	35/32	5½	41/8	131/32	½	¾	5/8	431/64	1,3425	3/8			UK205+HE2305		
UKPH206+H2306	25	90	161	121	50	17	21	17	130	38,1	M14	18525	10735	UK206+H2306	PH206	1,64
UKPH206+HS2306	7/8	335/64	611/32	4¾	131/32	43/64	53/64	43/64	51/8	1,5000	½			UK206+HS2306		
UKPH206+HE2306	1													UK206+HE2306		
UKPH207+H2307	30	95	166	127	60	17	21	18	140	42,9	M14	24415	14630	UK207+H2307	PH207	2,03
UKPH207+HS2307	11/8	347/64	617/32	5	223/64	43/64	53/64	45/64	533/64	1,6890	½			UK207+HS2307		
UKPH208+H2308	35	100	178	137	70	17	21	19	150	49,2	M14	27645	16910	UK208+H2308	PH208	2,72
UKPH208+HE2308	1¼	315/16	71/64	512/32	2¾	43/64	53/64	¾	529/32	1,9370	½			UK208+HE2308		
UKPH208+HS2308	13/8													UK208+HS2308		
UKPH209+H2309	40	105	189	146	70	17	21	20	158	49,2	M14	32395	20235	UK209+H2309	PH209	3,09
UKPH209+HA2309	17/16	49/64	77/16	5¾	2¾	43/64	53/64	25/32	67/32	1,9370	½			UK209+HA2309		
UKPH209+HE2309	1½													UK209+HE2309		
UKPH209+HS2309	15/8													UK209+HS2309		
UKPH210+H2310	45	110	205	159	70	20	23	21	165	51,6	M16	33345	22135	UK210+H2310	PH210	3,59
UKPH210+HS2310	15/8	421/64	85/64	6¼	2¾	25/32	29/32	53/64	6½	2,0315	5/8			UK210+HS2310		
UKPH210+HA2310	111/16													UK210+HA2310		
UKPH210+HE2310	1¾													UK210+HE2310		

Bussole HA; HE; HS con filettatura in pollici
Inch dimension adapter sleeves HA; HE; HS

UCPA2 Serie normale - Standard duty

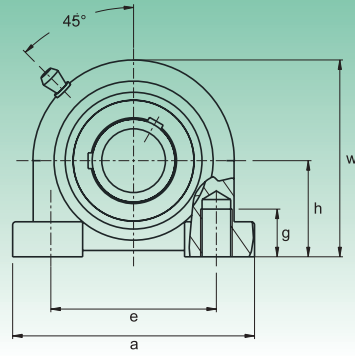
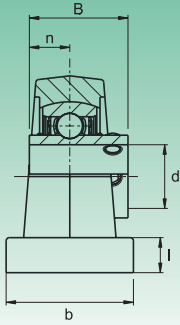

Tipo Type	Dimensioni - Dimensions										Bull. fiss. Bolt Size	Coefficients di carico (N) Load ratings (N)		Cuscinetto Bearing	Supporto Housing	Peso Weight	
	d	h	a	e	b	g	l	w	B	n		Dinamico C Dynamic C	Statico C ₀ Static C ₀				kg
	mm/inch											mm/inch					
UCPA201	12	30,2	76	52	40	15	11	62	31	12,7	M10	12160	6318	UC201	PA204	0,60	
UCPA201-8	1/2	13/16	3	23/64	19/16	19/32	7/16	27/16	1,2205	0,500	3/8			UC201-8		0,59	
UCPA202	15	30,2	76	52	40	15	11	62	31	12,7	M10	12160	6318	UC202	PA204	0,59	
UCPA202-9	9/16	13/16	3	23/64	19/16	19/32	7/16	27/16	1,2205	0,500	3/8			UC202-9		0,59	
UCPA202-10	5/8	13/16	3	23/64	19/16	19/32	7/16	27/16	1,2205	0,500	3/8			UC202-10		0,59	
UCPA203	17	30,2	76	52	40	15	11	62	31	12,7	M10	12160	6318	UC203	PA204	0,58	
UCPA203-11	11/16	13/16	3	23/64	19/16	19/32	7/16	27/16	1,2205	0,500	3/8			UC203-11		0,57	
UCPA204	20	30,2	76	52	40	15	11	62	31	12,7	M10	12160	6318	UC204	PA204	0,56	
UCPA204-12	3/4	13/16	3	23/64	19/16	19/32	7/16	27/16	1,2205	0,500	3/8			UC204-12		0,56	
UCPA205	25	36,5	84	56	38	15	12	72	34,1	14,3	M10			UC205		0,83	
UCPA205-13	13/16													UC205-13		0,87	
UCPA205-14	7/8	17/16	35/16	213/64	1 1/2	19/32	15/32	253/64	1,3425	0,563	3/8	13300	7457	UC205-14	PA205	0,86	
UCPA205-15	15/16													UC205-15		0,84	
UCPA205-16	1													UC205-16		0,83	
UCPA206	30	42,9	94	66	50	18	12	84	38,1	15,9	M14			UC206		1,12	
UCPA206-17	11/16													UC206-17		1,15	
UCPA206-18	11/8	111/16	345/64	219/32	131/32	45/64	15/32	35/16	1,5000	0,626	1/2	18525	10735	UC206-18	PA206	1,14	
UCPA206-19	13/16													UC206-19		1,12	
UCPA206-20	1 1/4													UC206-20		1,11	
UCPA207	35	47,6	110	80	55	20	13	95	42,9	17,5	M14			UC207		1,48	
UCPA207-20	1 1/4													UC207-20		1,54	
UCPA207-21	15/16	17/8	421/64	35/32	211/64	25/32	33/64	347/64	1,6890	0,689	1/2	24415	14630	UC207-21	PA207	1,51	
UCPA207-22	13/8													UC207-22		1,48	
UCPA207-23	17/16													UC207-23		1,45	
UCPA208	40	49,2	116	84	58	20	13	100	49,2	19	M14			UC208		1,89	
UCPA208-24	1 1/2	115/16	49/16	35/16	29/32	25/32	33/64	315/16	1,9370	0,748	1/2	27645	16910	UC208-24	PA208	1,93	
UCPA208-25	19/16													UC208-25		1,90	
UCPA209	45	54,2	120	90	60	25	13	108	49,2	19	M14			UC209		1,98	
UCPA209-26	15/8													UC209-26	PA209	2,08	
UCPA209-27	111/16	29/64	423/32	335/64	223/64	63/64	33/64	4 1/4	1,9370	0,748	1/2	32395	20235	UC209-27		2,04	
UCPA209-28	1 3/4													UC209-28		2,00	
UCPA210	50	57,2	130	94	64	25	14	116	51,6	19	M16			UC210		2,16	
UCPA210-29	113/16													UC210-29	PA210	2,28	
UCPA210-30	17/8	2 1/4	51/8	345/64	233/64	63/64	35/64	49/16	2,0315	0,748	5/8	33345	22135	UC210-30		2,23	
UCPA210-31	115/16													UC210-31		2,18	
UCPA210-32	2													UC210-32		2,14	
UCPA211	55	63,5	140	104	66	25	14	125	55,6	22,2	M16			UC211		3,26	
UCPA211-32	2													UC211-32	PA211	3,41	
UCPA211-33	21/16	2 1/2	533/64	43/32	219/32	63/64	35/64	459/64	2,1890	0,874	5/8	41230	27930	UC211-33		3,35	
UCPA211-34	21/8													UC211-34		3,30	
UCPA211-35	23/16													UC211-35		3,24	
UCPA212	60	69,9	150	114	68	25	15	138	65,1	25,4	M16			UC212		4,19	
UCPA212-36	2 1/4													UC212-36	PA212	4,32	
UCPA212-37	25/16	2 3/4	529/32	431/64	243/64	63/64	19/32	57/16	2,5630	1,000	5/8	49780	34390	UC212-37		4,24	
UCPA212-38	23/8													UC212-38		4,17	
UCPA212-39	27/16													UC212-39		4,10	
UCPA213	65	76,2	160	124	70	25	15	150	65,1	25,4	M16			UC213		-	
UCPA213-40	2 1/2	3	619/64	47/8	2 3/4	63/64	19/32	529/32	2,5630	1,000	5/8	54340	38095	UC213-40	PA213	-	
UCPA213-41	29/16													UC213-41		-	

Disponibile in acciaio inox Supporto: AISI 304 - Cuscinetto: AISI 440C o 420C - Available stainless steel Housing: AISI 304 - Bearing: AISI 440C or 420C
 Disponibile su richiesta con cuscinetto SA (SAPA) - Available under request with SA bearing (SAPA)

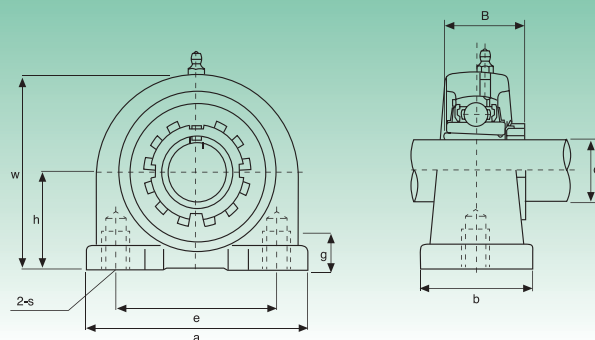
UKPA2 Serie normale - Standard duty

Tipo Type	Dimensioni - Dimensions								Bull. fiss. Bolt Size	Coefficienti di carico (N) Load ratings (N)		Cuscinetto Bearing	Supporto Housing	Peso Weight kg
	d	h	a	e	b	g	W	B		Dinamico C Dynamic C	Statico C ₀ Static C ₀			
	mm/inch									mm/inch				
UKPA205+H2305	20	36,5	84	56	38	15	72	34,1	M10	13300	7457	UK205+H2305	PA205	0,87
UKPA205+HE2305	¾	17/16	35/16	213/64	1½	19/32	253/64	1,3425	3/8			UK205+HE2305		
UKPA206+H2306	25	42,9	94	66	50	18	84	38,1	M14	18525	10735	UK206+H2306	PA206	1,24
UKPA206+HS2306	7/8	111/16	345/64	219/32	131/32	45/64	35/16	1,5000	½			UK206+HS2306		
UKPA206+HE2306	1											UK206+HE2306		
UKPA207+H2307	30	47,6	110	80	55	20	95	42,9	M14	24415	14630	UK207+H2307	PA207	1,73
UKPA207+HS2307	11/8	17/8	421/64	35/32	211/64	25/32	347/64	1,6890	½			UK207+HS2307		
UKPA208+H2308	35	49,2	116	84	58	20	100	49,2	M14	27645	16910	UK208+H2308	PA208	2,02
UKPA208+HE2308	1¼	115/16	49/16	35/16	29/32	25/32	315/16	1,9370	½			UK208+HE2308		
UKPA208+HS2308	13/8											UK208+HS2308		
UKPA209+H2309	40	54,2	120	90	60	25	108	49,2	M14	32395	20235	UK209+H2309	PA209	2,29
UKPA209+HA2309	17/16	29/64	423/32	335/64	223/64	63/64	4¼	1,9370	½			UK209+HA2309		
UKPA209+HE2309	1½											UK209+HE2309		
UKPA209+HS2309	15/8											UK209+HS2309		
UKPA210+H2310	45	57,2	130	94	64	25	116	51,6	M16	33345	22135	UK210+H2310	PA210	2,89
UKPA210+HS2310	15/8	2½	51/8	345/64	233/64	63/64	49/16	2,0315	5/8			UK210+HS2310		
UKPA210+HA2310	111/16											UK210+HA2310		
UKPA210+HE2310	1¾											UK210+HE2310		

Bussole HA; HE; HS con filettatura in pollici
Inch dimension adapter sleeves HA; HE; HS

UCFA2 Serie normale - Standard duty

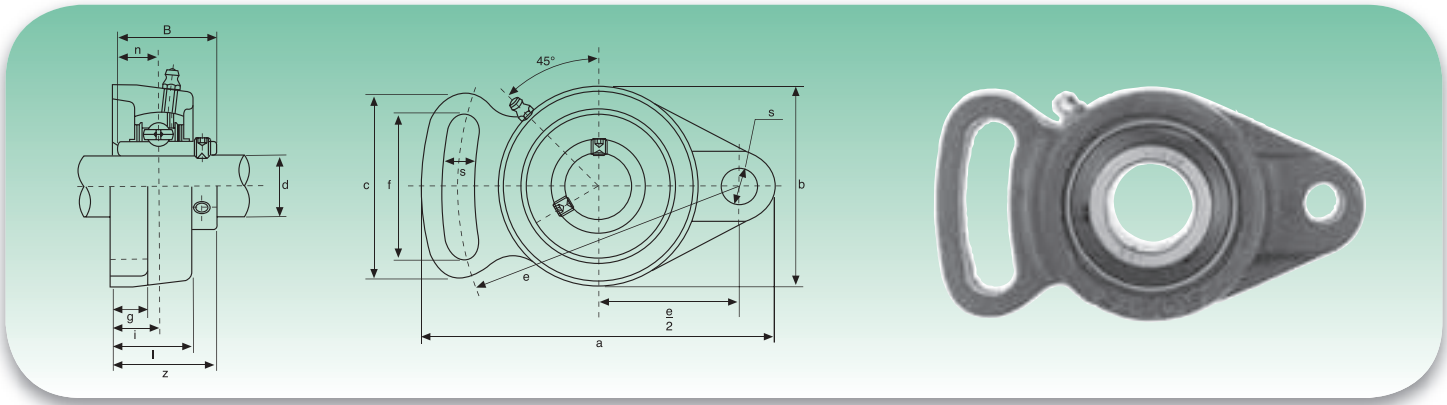

Tipo Type	Dimensioni - Dimensions												Bull. fiss. Bolt Size	Coefficienti di carico (N) Load ratings (N)		Cuscinetto Bearing	Supporto Housing	Peso Weight	
	d	a	e	i	g	l	s	b	z	f	c	B		n	Dinamico C Dynamic C _o				Statico C _o Static C _o
	mm/inch													mm/inch					
UCFA201	12	98	78	15	12	25,5	10	60	33,3	40	50	31	12,7	M8	12160	6318	UC201	FA204	0,50
UCFA201-8	½	355/64	35/64	19/32	15/32	1	25/64	23/8	15/16	137/64	131/32	1,2205	0,500	5/16			UC201-8		0,49
UCFA202	15	98	78	15	12	25,5	10	60	33,3	40	50	31	12,7	M8	12160	6318	UC202	FA204	0,49
UCFA202-9	9/16																UC202-9		0,49
UCFA202-10	5/8	355/64	35/64	19/32	15/32	1	25/64	23/8	15/16	137/64	131/32	1,2205	0,500	5/16			UC202-10		0,49
UCFA203	17	98	78	15	12	25,5	10	60	33,3	40	50	31	12,7	M8	12160	6318	UC203	FA204	0,48
UCFA203-11	11/16	355/64	35/64	19/32	15/32	1	25/64	23/8	15/16	137/64	131/32	1,2205	0,500	5/16			UC203-11		0,47
UCFA204	20	98	78	15	12	25,5	10	60	33,3	40	50	31	12,7	M8	12160	6318	UC204	FA204	0,46
UCFA204-12	¾	355/64	35/64	19/32	15/32	1	25/64	23/8	15/16	137/64	131/32	1,2205	0,500	5/16			UC204-12		0,46
UCFA205	25	124	98	16	14	27	13	70	35,8	51	65	34,1	14,3	M10			UC205		0,66
UCFA205-13	13/16																UC205-13		0,70
UCFA205-14	7/8	47/8	355/64	5/8	35/64	11/6	33/64	2¾	113/32	21/64	29/16	1,3425	0,563	3/8	13300	7457	UC205-14	FA205	0,69
UCFA205-15	15/16																UC205-15		0,67
UCFA205-16	1																UC205-16		0,66
UCFA206	30	141	115	18	14	31	13	83	40,2	58	72	38,1	15,9	M10			UC206		0,93
UCFA206-17	11/16																UC206-17		0,96
UCFA206-18	11/8	535/64	417/32	45/64	35/64	17/32	33/64	317/64	119/32	29/32	227/32	1,5000	0,626	3/8	18525	10735	UC206-18	FA206	0,95
UCFA206-19	13/16																UC206-19		0,93
UCFA206-20	1¼																UC206-20		0,92
UCFA207	35	155	128	19	16	34	15	96	44,4	66	82	42,9	17,5	M12			UC207		1,46
UCFA207-20	1¼																UC207-20		1,52
UCFA207-21	15/16	67/64	53/64	¾	5/8	111/32	19/32	325/32	1¾	219/32	315/64	1,6890	0,689	7/16	24415	14630	UC207-21	FA207	1,49
UCFA207-22	13/8																UC207-22		1,46
UCFA207-23	17/16																UC207-23		1,43
UCFA208	40	171	142	21	16	38	15	105	51,2	71	87	49,2	19	M12			UC208		1,78
UCFA208-24	1½	47/64	519/32	53/64	5/8	1½	19/32	49/64	21/64	251/64	327/64	1,9370	0,748	7/16	27645	16910	UC208-24	FA208	1,82
UCFA208-25	19/16																UC208-25		1,79
UCFA209	45	179	146	22	18	40	17	111	52,2	72	90	49,2	19	M14			UC209		2,03
UCFA209-26	15/8																UC209-26		2,13
UCFA209-27	111/16	73/64	5¾	55/64	45/64	137/64	43/64	43/8	21/16	253/64	335/64	1,9370	0,748	½	32395	20235	UC209-27	FA209	2,09
UCFA209-28	1¾																UC209-28		2,05
UCFA210	50	189	155	22	18	40	17	116	54,6	76	94	51,6	19	M14			UC210		2,23
UCFA210-29	113/16																UC210-29		2,35
UCFA210-30	17/8	77/16	67/64	55/64	45/64	137/64	43/64	49/16	25/32	3	345/64	2,0315	0,748	½	33345	22135	UC210-30	FA210	2,30
UCFA210-31	115/16																UC210-31		2,25
UCFA210-32	2																UC210-32		2,21
UCFA211	55	216	182	25	20	44	17	133	58,4	86	104	55,6	22,2	M14			UC211		3,2
UCFA211-32	2																UC211-32		4,5
UCFA211-33	21/16	8½	711/64	63/64	25/32	147/64	43/64	551/64	25/16	325/64	43/32	2,1890	0,874	½	41230	27930	UC211-33	FA211	4,20
UCFA211-34	21/8																UC211-34		4,10
UCFA211-35	23/16																UC211-35		4,00
UCFA212	60	240	202	29	20	48	19	140	68,7	100	118	65,1	25,4	M16			UC212		-
UCFA212-36	2¼																UC212-36		-
UCFA212-37	25/16	929/64	761/64	19/64	25/32	17/8	¾	5½	223/32	315/16	441/64	2,5630	1,000	5/8	49780	34390	UC212-37	FA212	-
UCFA212-38	23/8																UC212-38		-
UCFA212-39	27/16																UC212-39		-
UCFA213	65	250	210	30	20	50	19	155	69,7	102	122	65,1	25,4	M16			UC213		-
UCFA213-40	2½																UC213-40	FA213	-
UCFA213-41	29/16	927/32	817/64	13/16	25/32	131/32	¾	63/32	2¾	41/64	451/64	2,5630	1,000	5/8	54340	38095	UC213-41		-

Disponibile in acciaio inox Supporto: AISI 304 - Cuscinetto: AISI 440C o 420C - Available stainless steel Housing: AISI 304 - Bearing: AISI 440C or 420C
 Disponibile su richiesta con cuscinetto SA (SAFA) - Available under request with SA bearing (SAFA)

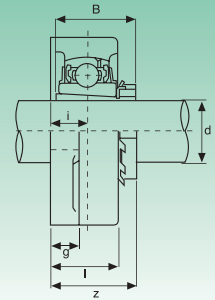
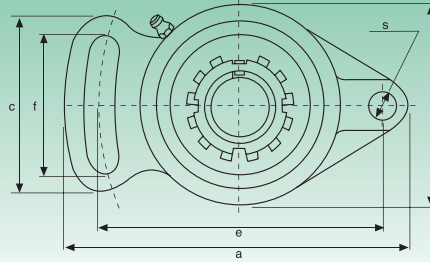
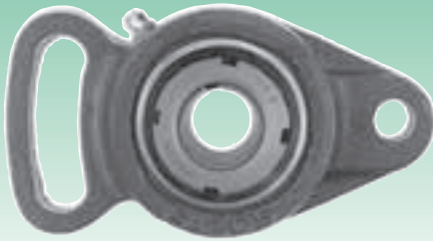
UKFA2 Serie normale - Standard duty

Tipo Type	Dimensioni - Dimensions												Bull. fiss. Bolt Size	Coefficienti di carico (N) Load ratings (N)		Cuscinetto Bearing	Supporto Housing	Peso Weight	
	d	a	e	i	g	l	s	b	z	f	c	B		Dinamico C Dynamic C	Statico C ₀ Static C ₀				kg
	mm/inch													mm/inch					
UKFA205+H2305	20	124	98	16	14	27	13	70	35,8	51	65	34,1	M10	13300	7457	UK205+H2305	FA205	0,71	
UKFA205+HE2305	¾	47/8	355/64	5/8	35/64	11/16	33/64	2¾	113/32	21/64	29/16	1,3425	3/8			UK205+HE2305			
UKFA206+H2306	25	141	115	18	14	31	13	83	40,2	58	72	38,1	M10	18525	10735	UK206+H2306	FA206	1,04	
UKFA206+HS2306	7/8	535/64	417/32	45/64	35/64	17/32	33/64	317/64	119/32	29/32	227/32	1,5000	3/8			UK206+HS2306			
UKFA206+HE2306	1															UK206+HE2306			
UKFA207+H2307	30	155	128	19	16	34	15	96	44,4	66	82	42,9	M12	24415	14630	UK207+H2307	FA207	1,5	
UKFA207+HS2307	11/8	67/64	53/64	¾	5/8	111/32	19/32	325/32	1¾	219/32	315/64	1,6890	7/16			UK207+HS2307			
UKFA208+H2308	35	171	142	21	16	38	15	105	51,2	71	87	49,2	M12	27645	16910	UK208+H2308	FA208	1,9	
UKFA208+HE2308	1¼	47/64	519/32	53/64	5/8	1½	19/32	49/64	21/64	251/64	327/64	1,9370	7/16			UK208+HE2308			
UKFA208+HS2308	13/8															UK208+HS2308			
UKFA209+H2309	40	179	146	22	18	40	17	111	52,2	72	90	49,2	M14	32395	20235	UK209+H2309	FA209	1,8	
UKFA209+HA2309	17/16	73/64	5¾	55/64	45/64	137/64	43/64	43/8	21/16	253/64	335/64	1,9370	½			UK209+HA2309			
UKFA209+HE2309	1½															UK209+HE2309			
UKFA209+HS2309	15/8															UK209+HS2309			
UKFA210+H2310	45	189	155	22	18	40	17	116	54,6	76	94	51,6	M14	33345	22135	UK210+H2310	FA210	2,1	
UKFA210+HS2310	15/8	111/16	71/16	67/64	55/64	45/64	137/64	43/64	49/16	25/32	3	345/64	2,0315			½			UK210+HS2310
UKFA210+HA2310	111/16																		UK210+HA2310
UKFA210+HE2310	1¾																		UK210+HE2310

Bussole HA; HE; HS con filettatura in pollici
Inch dimension adapter sleeves HA; HE; HS

UCFB2 Serie normale - Standard duty

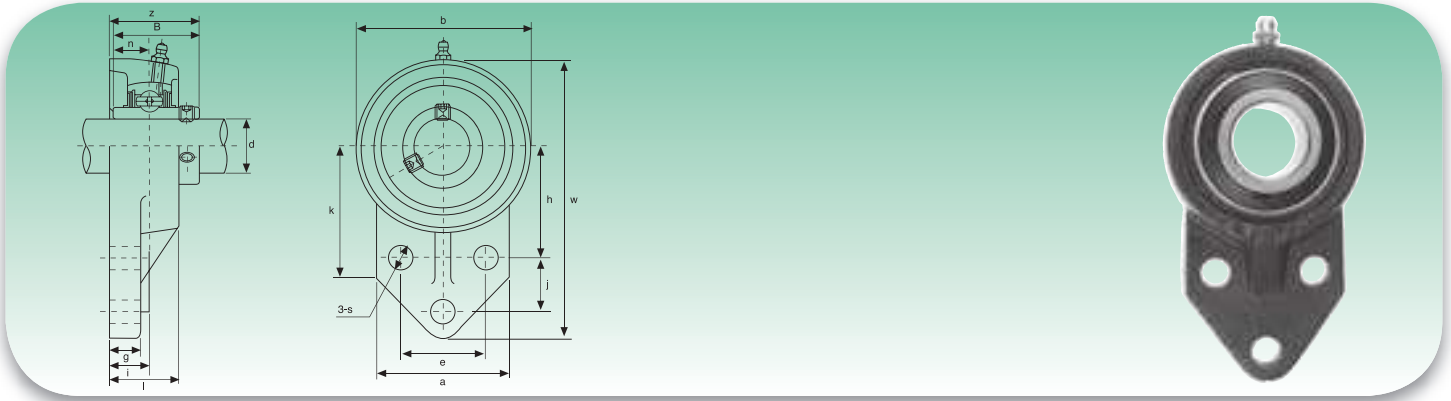

Tipo Type	Dimensioni - Dimensions														Bull. fiss. Bolt Size	Coefficienti di carico (N) Load ratings (N)		Cuscinetto Bearing	Supporto Housing	Peso Weight	
	d	w	b	k	a	l	s	g	h	j	e	i	z	B		n	Dinamico C Dynamic C _d				Statico C _s Static C _s
																				mm/inch	
UCFB201	12	110	62	52	52	25,5	10	13	42	27	32	15	33,3	31	12,7	M8	12160	6318	UC201	FB204	0,58
UCFB201-8	½	411/32	27/16	21/16	21/16	1	25/64	½	121/32	11/16	117/64	19/32	15/16	1,2205	0,500	5/16			UC201-8		0,57
UCFB202	15	110	62	52	52	25,5	10	13	42	27	32	15	33,3	31	12,7	M8	12160	6318	UC202	FB204	0,57
UCFB202-9	9/16	411/32	27/16	21/16	21/16	1	25/64	½	121/32	11/16	117/64	19/32	15/16	1,2205	0,500	5/16			UC202-9		0,57
UCFB202-10	5/8	411/32	27/16	21/16	21/16	1	25/64	½	121/32	11/16	117/64	19/32	15/16	1,2205	0,500	5/16			UC202-10		0,57
UCFB203	17	110	62	52	52	25,5	10	13	42	27	32	15	33,3	31	12,7	M8	12160	6318	UC203	FB204	0,56
UCFB203-11	11/16	411/32	27/16	21/16	21/16	1	25/64	½	121/32	11/16	117/64	19/32	15/16	1,2205	0,500	5/16			UC203-11		0,55
UCFB204	20	110	62	52	52	25,5	10	13	42	27	32	15	33,3	31	12,7	M8	12160	6318	UC204	FB204	0,54
UCFB204-12	¾	411/32	27/16	21/16	21/16	1	25/64	½	121/32	11/16	117/64	19/32	15/16	1,2205	0,500	5/16			UC204-12		0,54
UCFB205	25	116	68	52	56	27	10	13	45	27	34	16	35,8	34,1	14,3	M8	13300	7457	UC205	FB205	0,79
UCFB205-13	13/16	49/16	211/16	21/16	27/32	11/16	25/64	½	149/64	11/16	111/32	5/8	113/32	1,3425	0,563	5/16			UC205-13		0,83
UCFB205-14	7/8																	UC205-14		0,82	
UCFB205-15	15/16																	UC205-15		0,80	
UCFB205-16	1																	UC205-16		0,79	
UCFB206	30	130	78	55	65	31	10	13	50	29	40	18	40,2	38,1	15,9	M8	18525	10735	UC206	FB206	0,95
UCFB206-17	11/16	51/8	31/16	25/32	29/16	17/32	25/64	½	131/32	19/64	137/64	45/64	119/32	1,5000	0,626	5/16			UC206-17		0,98
UCFB206-18	11/8																	UC206-18		0,97	
UCFB206-19	13/16																	UC206-19		0,95	
UCFB206-20	1¼																	UC206-20		0,94	
UCFB207	35	144	90	62	70	34	10	15	55	32	46	19	44,4	42,9	17,5	M8	24415	14630	UC207	FB207	1,29
UCFB207-20	1¼	521/32	335/64	27/16	2¾	111/32	25/64	19/32	211/64	117/64	113/16	¾	1¾	1,6890	0,689	5/16			UC207-20		1,35
UCFB207-21	15/16																	UC207-21		1,32	
UCFB207-22	13/8																	UC207-22		1,29	
UCFB207-23	17/16																	UC207-23		1,26	
UCFB208	40	164	100	72	78	36	12	16	60	41	50	21	51,2	49,2	19	M10	27645	16910	UC208	FB208	1,78
UCFB208-24	1½	615/32	315/16	227/32	31/16	113/32	15/32	5/8	223/64	139/64	131/32	53/64	21/64	1,9370	0,748	3/8			UC208-24		1,82
UCFB208-25	19/16																	UC208-25		1,79	
UCFB209	45	174	106	76	80	38	12	18	65	43	54	22	52,2	49,2	19	M10	32395	20235	UC209	FB209	1,91
UCFB209-26	15/8	627/32	43/16	3	35/32	1½	15/32	23/32	29/16	111/16	21/8	55/64	21/16	1,9370	0,748	3/8			UC209-26		2,01
UCFB209-27	111/16																	UC209-27		1,97	
UCFB209-28	1¾																	UC209-28		1,93	
UCFB210	50	184	112	82	86	40	12	18	68	46	58	22	54,6	51,6	19	M10	33345	22135	UC210	FB210	2,36
UCFB210-29	113/16	71/14	413/32	37/32	33/8	137/64	15/32	23/32	243/64	113/16	29/32	55/64	25/32	2,0315	0,748	3/8			UC210-29		2,48
UCFB210-30	17/8																	UC210-30		2,43	
UCFB210-31	115/16																	UC210-31		2,38	
UCFA210-32	2																	UC210-32		2,34	
UCFB211	55	207	130	86	90	43	14	18	78	50	62	25	58,4	55,6	22,2	M12	41230	27930	UC211	FB211	3,15
UCFB211-32	2	85/32	51/8	325/64	335/64	111/16	35/64	45/64	35/64	131/32	27/16	63/64	25/16	2,1890	0,874	7/16			UC211-32		3,31
UCFB211-33	21/16																	UC211-33		3,25	
UCFB211-34	21/8																	UC211-34		3,20	
UCFB211-35	23/16																	UC211-35		3,14	
UCFB212	60	223	140	90	94	48	14	18	84	55	66	29	68,7	65,1	25,4	M12	49780	34390	UC212	FB212	3,99
UCFB212-36	2¼	825/32	5½	335/64	345/64	17/8	35/64	45/64	35/16	211/64	219/32	19/64	223/32	2,5630	1,000	7/16			UC212-36		4,12
UCFB212-37	25/16																	UC212-37		4,04	
UCFB212-38	23/8																	UC212-38		3,97	
UCFB212-39	27/16																	UC212-39		3,90	
UCFB213	65	244	155	94	100	50	14	20	92	60	70	30	69,7	65,1	25,4	M12	54340	38095	UC213	FB213	-
UCFB213-40	2½	939/64	67/64	345/64	315/16	131/32	35/64	25/32	35/8	223/64	2¾	13/16	2¾	2,5630	1,000	7/16			UC213-40		-
UCFB213-41	29/16																	UC213-41		-	

Disponibile in acciaio inox Supporto: AISI 304 - Cuscinetto: AISI 440C o 420C - Available stainless steel Housing: AISI 304 - Bearing: AISI 440C or 420C
Disponibile su richiesta con cuscinetto SA (SAFB) - Available under request with SA bearing (SAFB)

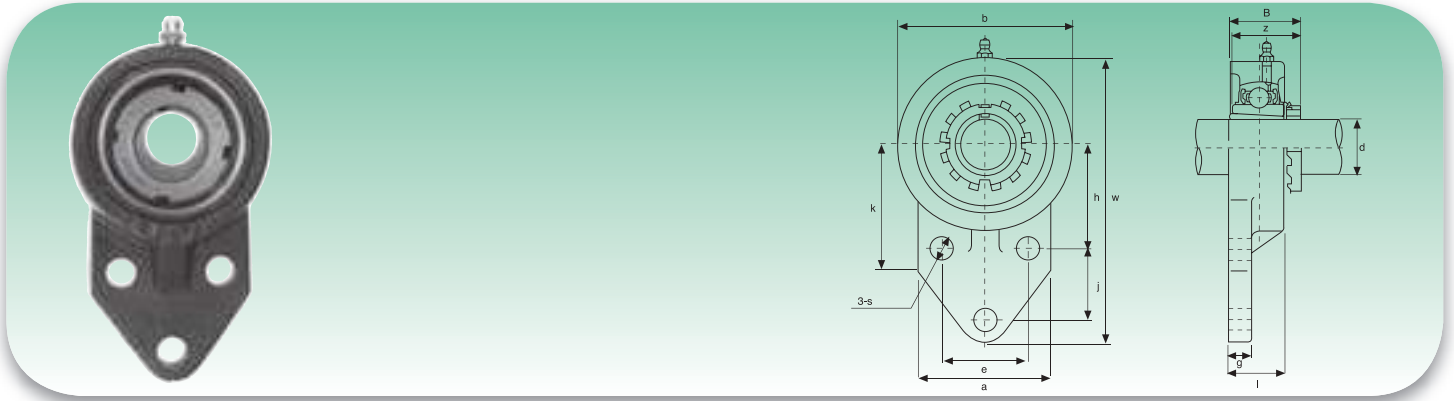
UKFB2 Serie normale - Standard duty

Tipo Type	Dimensioni - Dimensions														Bull. fiss. Bolt Size	Coefficients di carico (N) Load ratings (N)		Cuscinetto Bearing	Supporto Housing	Peso Weight	
	d	w	b	k	a	l	s	g	h	j	e	i	z	B		Dinamico C Dynamic C	Statico C ₀ Static C ₀				kg
	mm/inch															mm/inch					
UKFB205+H2305	20	116	68	52	56	27	10	13	45	27	34	16	35,8	34,1	M8	13300	7457	UK205+H2305	FB205	0,72	
UKFB205+HE2305	¾	49/16	211/16	21/16	27/32	11/16	25/64	½	149/64	11/16	111/32	5/8	113/32	1,3425	5/16			UK205+HE2305			
UKFB206+H2306	25	130	78	55	65	31	10	13	50	29	40	18	40,2	38,1	M8	18525	10735	UK206+H2306	FB206	0,96	
UKFB206+HS2306	7/8	51/8	31/16	25/32	29/16	17/32	25/64	½	131/32	19/64	137/64	45/64	119/32	1,5000	5/16			UK206+HS2306			
UKFB206+HE2306	1																	UK206+HE2306			
UKFB207+H2307	30	144	90	62	70	34	10	15	55	32	46	19	44,4	42,9	M8	24415	14630	UK207+H2307	FB207	1,33	
UKFB207+HS2307	11/8	521/32	335/64	27/16	2¾	111/32	25/64	19/32	211/64	117/64	113/16	¾	1¾	1,6890	5/16			UK207+HS2307			
UKFB208+H2308	35	164	100	72	78	36	12	16	60	41	50	21	51,2	49,2	M10	27645	16910	UK208+H2308	FB208	1,82	
UKFB208+HE2308	1¼	615/32	315/16	227/32	31/16	113/32	15/32	5/8	223/32	139/64	131/32	53/64	21/64	1,9370	3/8			UK208+HE2308			
UKFB208+HS2308	13/8																	UK208+HS2308			
UKFB209+H2309	40	174	106	76	80	38	12	18	65	43	54	22	52,2	49,2	M10	32395	20235	UK209+H2309	FB209	2,09	
UKFB209+HA2309	17/16	627/32	43/16	3	35/32	1½	15/32	23/32	29/16	111/16	21/8	55/64	21/16	1,9370	3/8			UK209+HA2309			
UKFB209+HE2309	1½																	UK209+HE2309			
UKFB209+HS2309	15/8																	UK209+HS2309			
UKFB210+H2310	45	184	112	82	86	40	12	18	68	46	58	22	54,6	51,6	M10	33345	22135	UK210+H2310	FB210	2,39	
UKFB210+HS2310	15/8	111/16	7¼	413/32	37/32	33/8	137/64	15/32	23/32	243/64	113/16	29/32	55/64	25/32	2,0315			3/8			UK210+HS2310
UKFB210+HA2310	111/16																				UK210+HA2310
UKFB210+HE2310	1¾																				UK210+HE2310

Bussole HA; HE; HS con filettatura in pollici
Inch dimension adapter sleeves HA; HE; HS

UCECH2 Serie normale - Standard duty

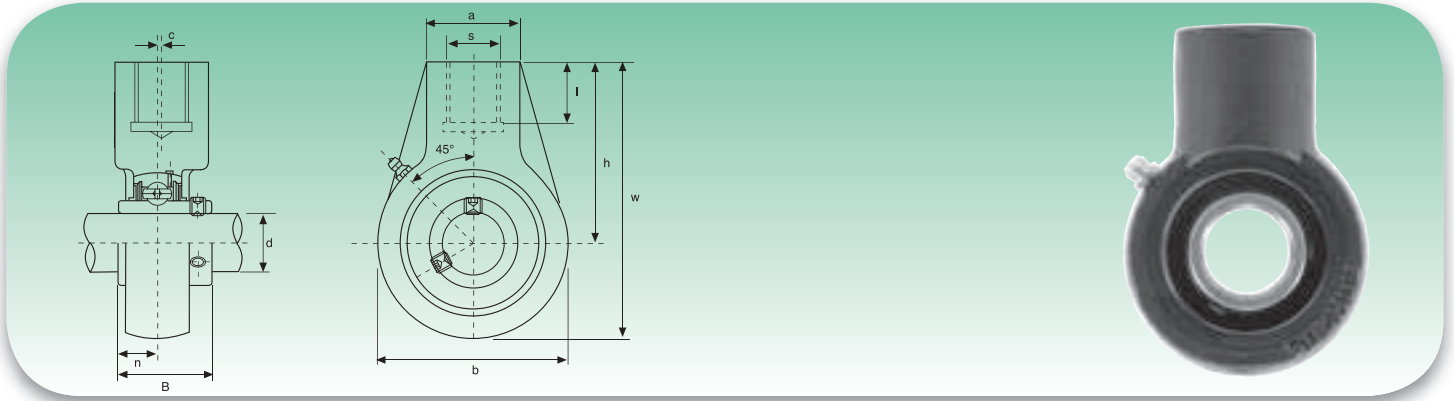

Tipo Type	Dimensioni - Dimensions										Coefficients di carico (N) Load ratings (N)		Cuscinetto Bearing	Supporto Housing	Peso Weight
	d	h	w	b	c	a	l	B	n	S	Dinamico C Dynamic C _d	Statico C ₀ Static C ₀			
	mm/inch														
UCECH201	12	64	96	64	0	40	19	31	12,7	G _{3/4}	12160	6318	UC201	ECH204	0,73
UCECH201-8	1/2	233/64	325/32	233/64	0	137/64	3/4	1,2205	0,500				UC201-8		0,72
UCECH202	15	64	96	64	0	40	19	31	12,7	G _{3/4}	12160	6318	UC202	ECH204	0,72
UCECH202-9	9/16	233/64	325/32	233/64	0	137/64	3/4	1,2205	0,500				UC202-9		0,72
UCECH202-10	5/8	233/64	325/32	233/64	0	137/64	3/4	1,2205	0,500				UC202-10		0,72
UCECH203	17	64	96	64	0	40	19	31	12,7	G _{3/4}	12160	6318	UC203	ECH204	0,71
UCECH203-11	11/16	233/64	325/32	233/64	0	137/64	3/4	1,2205	0,500				UC203-11		0,70
UCECH204	20	64	96	64	0	40	19	31	12,7	G _{3/4}	12160	6318	UC204	ECH204	0,69
UCECH204-12	3/4	233/64	325/32	233/64	0	137/64	3/4	1,2205	0,500				UC204-12		0,69
UCECH205	25	64	103	78	0	40	19	34,1	14,3				UC205	ECH205	0,83
UCECH205-13	13/16	233/64	41/16	35/64	0	137/64	3/4	1,3425	0,563				UC205-13		0,87
UCECH205-14	7/8	233/64	41/16	35/64	0	137/64	3/4	1,3425	0,563				UC205-14		0,86
UCECH205-15	15/16	233/64	41/16	35/64	0	137/64	3/4	1,3425	0,563				UC205-15		0,84
UCECH205-16	1	233/64	41/16	35/64	0	137/64	3/4	1,3425	0,563				UC205-16		0,83
UCECH206	30	64	103	78	0	40	19	38,1	15,9				UC206	ECH206	0,83
UCECH206-17	11/16	233/64	41/16	35/64	0	137/64	3/4	1,5000	0,626				UC206-17		0,86
UCECH206-18	11/8	233/64	41/16	35/64	0	137/64	3/4	1,5000	0,626				UC206-18		0,85
UCECH206-19	13/16	233/64	41/16	35/64	0	137/64	3/4	1,5000	0,626				UC206-19		0,83
UCECH206-20	1 1/4	233/64	41/16	35/64	0	137/64	3/4	1,5000	0,626				UC206-20		0,82
UCECH207	35	70	116	92	0	40	19	42,9	17,5				UC207	ECH207	1,16
UCECH207-20	1 1/4	233/64	49/16	35/8	0	137/64	3/4	1,6890	0,689				UC207-20		1,22
UCECH207-21	15/16	2 3/4	49/16	35/8	0	137/64	3/4	1,6890	0,689				UC207-21		1,19
UCECH207-22	13/8	2 3/4	49/16	35/8	0	137/64	3/4	1,6890	0,689				UC207-22		1,16
UCECH207-23	17/16	2 3/4	49/16	35/8	0	137/64	3/4	1,6890	0,689				UC207-23		1,13
UCECH208	40	73	121	96	2	40	19	49,2	19	G _{3/4}	27645	16910	UC208	ECH208	1,32
UCECH208-24	1 1/2	27/8	449/64	325/32	5/64	137/64	3/4	1,9370	0,748				UC208-24		1,36
UCECH208-25	19/16	27/8	449/64	325/32	5/64	137/64	3/4	1,9370	0,748				UC208-25		1,33
UCECH209	45	82	136	108	5	48	21	49,2	19	G ₁	32395	20235	UC209	ECH209	1,92
UCECH209-26	15/8	315/64	523/64	4 1/4	13/64	157/64	53/64	1,9370	0,748				UC209-26		2,02
UCECH209-27	111/16	315/64	523/64	4 1/4	13/64	157/64	53/64	1,9370	0,748				UC209-27		1,98
UCECH209-28	1 3/4	315/64	523/64	4 1/4	13/64	157/64	53/64	1,9370	0,748				UC209-28		1,94
UCECH210	50	83	142	118	5	48	21	51,6	19	G ₁	33345	22135	UC210	ECH210	1,90
UCECH210-29	113/16	317/64	519/32	441/64	13/64	157/64	77/83/64	2,0315	0,748				UC210-29		2,02
UCECH210-30	17/8	317/64	519/32	441/64	13/64	157/64	77/83/64	2,0315	0,748				UC210-30		1,97
UCECH210-31	115/16	317/64	519/32	441/64	13/64	157/64	77/83/64	2,0315	0,748				UC210-31		1,92
UCECH210-32	2	317/64	519/32	441/64	13/64	157/64	77/83/64	2,0315	0,748				UC210-32		1,88
UCECH211	55	87	150	126	7	60	25	55,6	22,2	G _{1 1/4}	41230	27930	UC211	ECH211	2,61
UCECH211-32	2	327/64	529/32	461/64	9/32	223/64	63/64	2,1890	0,874				UC211-32		2,76
UCECH211-33	21/16	327/64	529/32	461/64	9/32	223/64	63/64	2,1890	0,874				UC211-33		2,70
UCECH211-34	21/8	327/64	529/32	461/64	9/32	223/64	63/64	2,1890	0,874				UC211-34		2,65
UCECH211-35	23/16	327/64	529/32	461/64	9/32	223/64	63/64	2,1890	0,874				UC211-35		2,59
UCECH212	60	102	173	142	9	60	28	65,1	25,4	G _{1 1/4}	49780	34390	UC212	ECH212	3,54
UCECH212-36	2 1/4	41/64	613/16	519/32	23/64	223/64	17/64	2,5630	1,000				UC212-36		3,67
UCECH212-37	25/16	41/64	613/16	519/32	23/64	223/64	17/64	2,5630	1,000				UC212-37		3,59
UCECH212-38	23/8	41/64	613/16	519/32	23/64	223/64	17/64	2,5630	1,000				UC212-38		3,52
UCECH212-39	27/16	41/64	613/16	519/32	23/64	223/64	17/64	2,5630	1,000				UC212-39		3,45
UCECH213	65	117	200	166	9,5	70	32	65,1	25,4	G _{1 1/2}	54340	38095	UC213	ECH213	5,80
UCECH213-40	2 1/2	439/64	77/8	617/32	3/8	2 3/4	117/64	2,5630	1,000				UC213-40		5,89
UCECH213-41	29/16	439/64	77/8	617/32	3/8	2 3/4	117/64	2,5630	1,000				UC213-41		5,80
UCECH214	70	117	200	166	9,5	70	32	74,6	30,2	G _{1 1/2}	59090	41895	UC214	ECH214	5,67
UCECH214-42	25/8	439/64	77/8	617/32	3/8	2 3/4	117/64	2,9370	1,189				UC214-42		5,67
UCECH214-43	211/16	439/64	77/8	617/32	3/8	2 3/4	117/64	2,9370	1,189				UC214-43		5,67
UCECH214-44	2 3/4	439/64	77/8	617/32	3/8	2 3/4	117/64	2,9370	1,189				UC214-44		5,67
UCECH215	75	117	200	166	9,5	70	32	77,8	33,3	G _{1 1/2}	64030	45885	UC215	ECH215	5,58
UCECH215-45	213/16	439/64	731/32	617/32	3/8	2 3/4	117/64	3,0630	1,311				UC215-45		5,58
UCECH215-46	27/8	439/64	731/32	617/32	3/8	2 3/4	117/64	3,0630	1,311				UC215-46		5,58
UCECH215-47	215/16	439/64	731/32	617/32	3/8	2 3/4	117/64	3,0630	1,311				UC215-47		5,58
UCECH215-48	3	439/64	731/32	617/32	3/8	2 3/4	117/64	3,0630	1,311				UC215-48		5,58

Disponibile in acciaio inox Supporto: AISI 304 - Cuscinetto: AISI 440C o 420C - Available stainless steel Housing: AISI 304 - Bearing: AISI 440C or 420C
Disponibile su richiesta con cuscinetto SA (SAECH) - Available under request with SA bearing (SAECH)

S - Su richiesta disponibili con filetto metrico, in pollici e gas
S - Under request available with metric, inches and gas thread

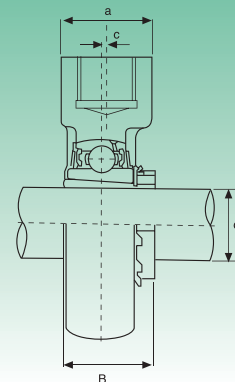
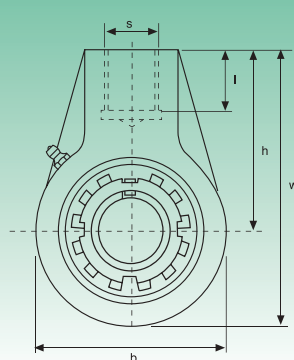
UKECH2 Serie normale - Standard duty

Tipo Type	Dimensioni - Dimensions									Coefficients di carico (N) Load ratings (N)		Cuscinetto Bearing	Supporto Housing	Peso Weight kg	
	d	h	w	b	c	a	l	B	S	Dinamico C Dynamic C	Statico C ₀ Static C ₀				
	mm/inch														
UKECH205+H2305	20	64	103	78	0	40	19	34,1		G $\frac{3}{4}$	13300	7457	UK205+H2305	ECH205	0,9
UKECH205+HE2305	$\frac{3}{4}$	233/64	41/16	35/64	0	137/64	$\frac{3}{4}$	1,3425					UK205+HE2305		
UKECH206+H2306	25	64	103	78	0	40	19	38,1		G $\frac{3}{4}$	18525	10735	UK206+H2306	ECH206	0,9
UKECH206+HS2306	$\frac{7}{8}$	233/64	41/16	35/64	0	137/64	$\frac{3}{4}$	1,5000					UK206+HS2306		
UKECH206+HE2306	1												UK206+HE2306		
UKECH207+H2307	30	70	116	92	0	40	19	42,9		G $\frac{3}{4}$	24415	14630	UK207+H2307	ECH207	1,23
UKECH207+HS2307	$\frac{11}{8}$	$2\frac{3}{4}$	49/16	35/8	0	137/64	$\frac{3}{4}$	1,6890					UK207+HS2307		
UKECH208+H2308	35	73	121	96	2	40	19	49,2		G $\frac{3}{4}$	27645	16910	UK208+H2308	ECH208	1,32
UKECH208+HE2308	$1\frac{1}{4}$	27/8	449/64	325/32	5/64	137/64	$\frac{3}{4}$	1,9370					UK208+HE2308		
UKECH208+HS2308	$\frac{13}{8}$												UK208+HS2308		
UKECH209+H2309	40	82	136	108	5	48	21	49,2		G1	32395	20235	UK209+H2309	ECH209	1,79
UKECH209+HA2309	$\frac{17}{16}$												UK209+HA2309		
UKECH209+HE2309	$1\frac{1}{2}$	315/64	523/64	4 $\frac{1}{4}$	13/64	157/64	53/64	1,9370					UK209+HE2309		
UKECH209+HS2309	$\frac{15}{8}$												UK209+HS2309		
UKECH210+H2310	45	83	142	118	5	48	21	51,6		G1	33345	22135	UK210+H2310	ECH210	2,19
UKECH210+HS2310	$\frac{15}{8}$												UK210+HS2310		
UKECH210+HA2310	$\frac{111}{16}$	317/64	519/32	441/64	13/64	157/64	53/64	2,0315					UK210+HA2310		
UKECH210+HE2310	$1\frac{3}{4}$												UK210+HE2310		
UKECH211+H2311	50	87	150	126	7	60	25	55,6		G $1\frac{1}{4}$	41230	27930	UK211+H2311	ECH211	2,84
UKECH211+HS2311	$\frac{17}{8}$												UK211+HS2311		
UKECH211+HA2311	$\frac{115}{16}$	327/64	529/32	461/64	9/32	223/64	63/64	2,1890					UK211+HA2311		
UKECH211+HE2311	2												UK211+HE2311		
UKECH212+H2312	55	102	173	142	9	60	28	65,1		G $1\frac{1}{4}$	49780	34390	UK212+H2312	ECH212	3,81
UKECH212+HS2312	$\frac{21}{8}$	41/64	613/16	519/32	23/64	223/64	17/64	2,5630					UK212+HS2312		

Bussole HA; HE; HS con filettatura in pollici

Inch dimension adapter sleeves HA; HE; HS

S - Su richiesta disponibili con filetto metrico, in pollici e gas

S - Under request available with metric, inches and gas thread

UP Serie leggera - Light duty

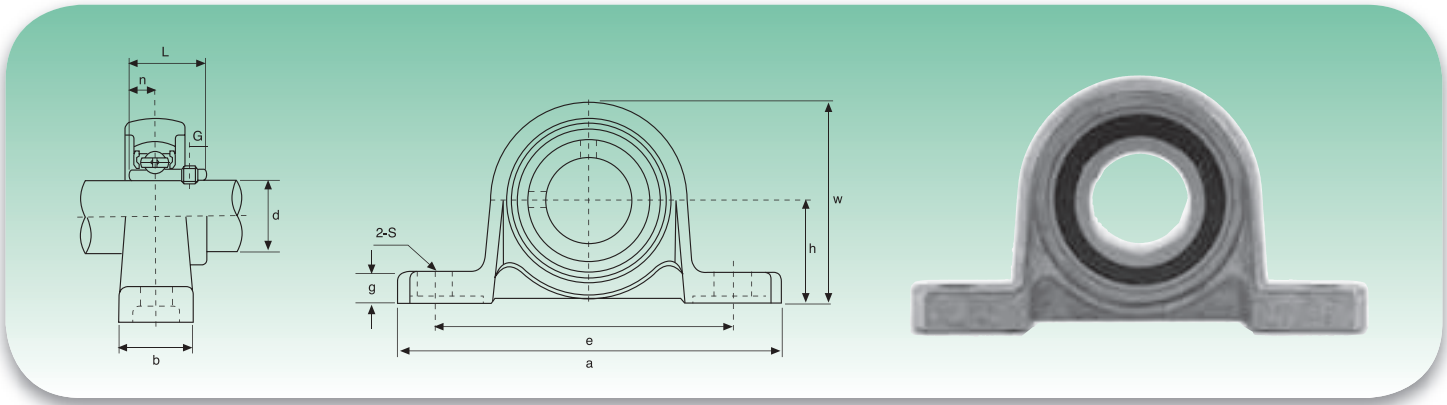

Tipo Type	Dimensioni - Dimensions											Bull. fiss. Bolt Size	Coefficienti di carico (N) Load ratings (N)		Cuscinetto Bearing	Supporto Housing	Peso Weight kg
	d	h	a	e	b	s	g	w	L	n	G		Dinamico C Dynamic C	Statico C ₀ Static C ₀			
	mm/inch												mm/inch				
UP000	10	18	67	53	16	7	6	35	17,5	4	4	M6	4322	1852	U000	LP000	0,077
UP001	12	19	71	56	16	7	6	38	14,5	4	4	M6	4845	2280	U001	LP001	0,091
UP002	15	22	80	63	16	6	7	43	16,5	4,5	4	M6	5320	2707	U002	LP002	0,125
UP003	17	24	85	67	18	6	7	47	17,5	5	4	M6	5700	3087	U003	LP003	0,156
UP004	20	28	100	80	20	10	9	55	21	6	4,5	M8	8930	4797	U004	LP004	0,230
UP005	25	32	112	90	20	10	10	62	22,5	6	5	M8	9595	5557	U005	LP005	0,294
UP006	30	36	132	106	26	13	11	70	24,5	6,5	5	M10	12540	7837	U006	LP006	0,454
UP007	35	40	150	118	26	13	13	80	25,5	7	6	M10	14750	9750	U007	LP007	0,593

Disponibile su richiesta in acciaio inox supporto: AISI 304 - Cuscinetto: AISI 440C 0 420C - Available under request stainless steel housing: AISI 304 - Bearing: AISI 440C or 420C
 Su richiesta fornibili anche con anello di serraggio eccentrico - Under request available with eccentric collar locking

SUPPORTI A FLANGIA OVALE IN ALLUMINIO - ALUMINIUM OVAL BEARING UNITS

UFL Serie leggera - Light duty

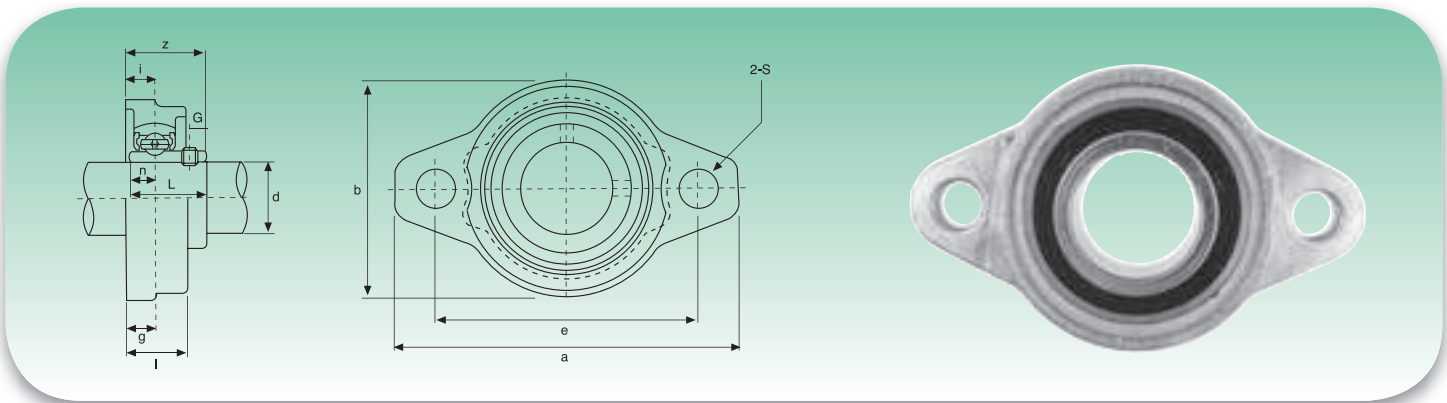

Tipo Type	Dimensioni - Dimensions											Bull. fiss. Bolt Size	Coefficienti di carico (N) Load ratings (N)		Cuscinetto Bearing	Supporto Housing	Peso Weight kg	
	d	a	e	i	g	l	s	b	Z	L	n		G	Dinamico C Dynamic C				Statico C ₀ Static C ₀
	mm/inch												mm/inch					
UFL000	10	60	45	5,5	5,5	11,5	7	36	15,5	14	4	4	M6	4322	1852	U000	FL000	0,063
UFL001	12	63	48	5,5	5,5	11,5	7	38	16	14,5	4	4	M6	4845	2280	U001	FL001	0,076
UFL002	15	67	53	6,5	6,5	13	7	42	18,5	16,5	4,5	4	M6	5320	2707	U002	FL002	0,100
UFL003	17	71	56	7	7	14	7	46	19,5	17,5	5	4	M6	5700	3087	U003	FL003	0,129
UFL004	20	90	71	8	8	16	10	55	23	21	6	4,5	M8	8930	4797	U004	FL004	0,205
UFL005	25	95	75	8	8	16	10	60	24,5	22,5	6	5	M8	9595	5557	U005	FL005	0,244
UFL006	30	112	85	9	9	18	13	70	27	24,5	6,5	5	M10	12540	7837	U006	FL006	0,354
UFL007	35	122	95	10	10	20	13	80	30,5	27,5	7	6	M10	14750	9750	U007	FL007	0,498

Disponibile su richiesta in acciaio inox supporto: AISI 304 - Cuscinetto: AISI 440C 0 420C - Available under request stainless steel housing: AISI 304 - Bearing: AISI 440C or 420C
 Su richiesta fornibili anche con anello di serraggio eccentrico - Under request available with eccentric collar locking

Supporti in serie leggera in lega d'alluminio, fissaggio con grani. Un nuovo concetto di supporto; offre una significativa riduzione di peso ed ingombro rispetto alle normali serie, con risparmio economico nella progettazione di macchine.
 Extra light duty bearing units available with set screws, a totally new concept in bearing units, offer a significant reduction in size and weight when compared with the same size of existing series. This unique design promotes both space and material saving in machine tool and general equipment application.

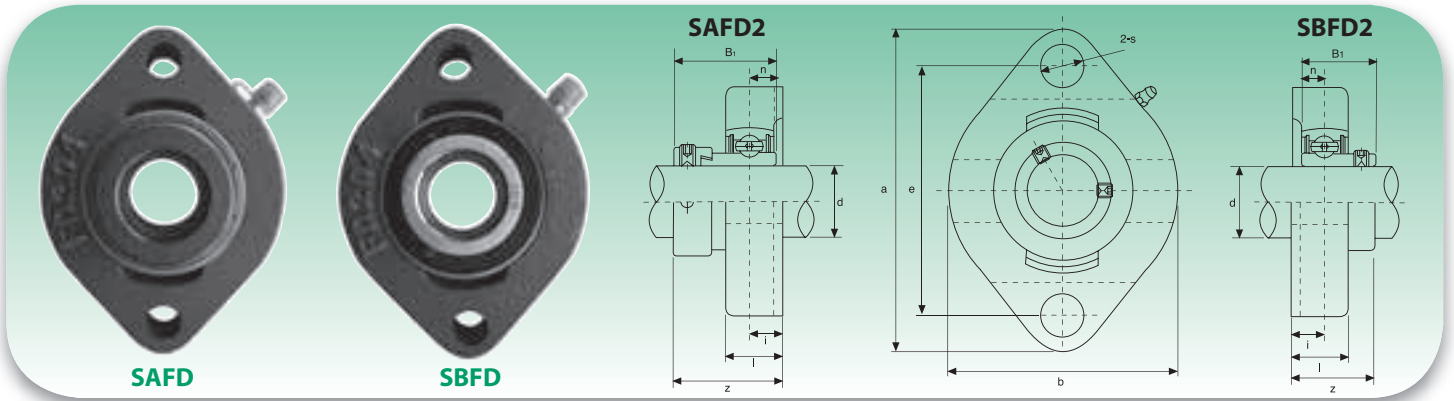
SAFD2 - SBFD2

Tipo Type	Dimensioni - Dimensions							Bull. fiss. Bolt Size	SAFD			Cuscinetto Bearing	Peso Weight	SBFD			Cuscinetto Bearing	Peso Weight	Supporto Housing	Coefficienti di carico (N) Load ratings (N)	
	d	a	e	b	i	s	l		z	B ₁	n			z	B ₁	n				Dinamico C Dynamic C	Statico C ₀ Static C ₀
	mm/inch								mm/inch					mm/inch							
SAFD-SBFD 201	12	81	63	59	8,5	7	15	M6	30,6	28,6	6,5	SA201	0,3	24	22	6	SB201	0,3	FD203	9200	4480
201-8	½	33/16	231/64	221/64	21/64	9/32	19/32	¼	113/64	1,1260	0,2559	SA201-8		61/64	0,8661	0,2362	SB201-8				
SAFD-SBFD 202	15	81	63	59	8,5	7	15	M6	30,6	28,6	6,5	SA202	0,3	24	22	6	SB202	0,3	FD203	9200	4480
202-9	9/16											SA202-9					SB202-9				
202-10	5/8	33/16	231/64	221/64	21/64	9/32	19/32	¼	113/64	1,1260	0,2559	SA202-10		61/64	0,8661	0,2362	SB202-10				
SAFD-SBFD 203	17	81	63	59	8,5	7	15	M6	30,6	28,6	6,5	SA203	0,3	24	22	6	SB203	0,3	FD203	9200	4480
203-11	11/16	33/16	231/64	221/64	21/64	9/32	19/32	¼	113/64	1,1260	0,2559	SA203-11		61/64	0,8661	0,2362	SB203-11				
SAFD-SBFD 204	20	90	71	67	9,5	10	17	M8	33	31	7,5	SA204	0,5	27,5	25	7	SB204	0,4	FD204	12200	6300
204-12	¾	335/64	251/64	241/64	3/8	25/64	43/64	5/16	119/64	1,2204	0,2953	SA204-12		15/64	0,9843	0,2756	SB204-12				
SAFD-SBFD 205	25	95	76	71	9,5	10	17	M8	33	31	7,5	SA205	0,5	29	27	7,5	SB205	0,5	FD205	13300	7460
205-13	13/16										SA205-13										
205-14	7/8	3¾	263/64	251/64	3/8	25/64	43/64	5/16	119/64	1,2204	0,2953	SA205-14									
205-15	15/16										SA205-15										
205-16	1										SA205-16										
SAFD-SBFD 206	30	113	90	84	12	12	21	M10	38,7	35,7	9	SA206	0,8	34	30	8	SB206	0,8	FD206	18500	10800
206-17	11/16										SA206-17										
206-18	11/8	47/16	335/64	351/16	15/32	15/32	53/64	3/8	117/32	1,4055	0,3543	SA206-18									
206-19	13/16										SA206-19										
206-20	1¼										SA206-20										
SAFD-SBFD 207	35	125	100	94	12,5	12	22	M10	41,9	38,9	9,5	SA207	1,0	36	32	8,5	SB207	0,9	FD207	24500	14600
207-20	1¼										SA207-20										
207-21	15/16	459/64	315/16	345/64	½	15/32	7/8	3/8	121/32	1,5315	0,3740	SA207-21									
207-22	13/8										SA207-22										
205-23	17/16										SA205-23										
SAFD-SBFD 208	40	149	119	104	15	14	25	M12	45,7	-	11	SA208	1,4	41	-	9	SB208	1,2	FD208	27700	17000

SALF2 - SBLF2

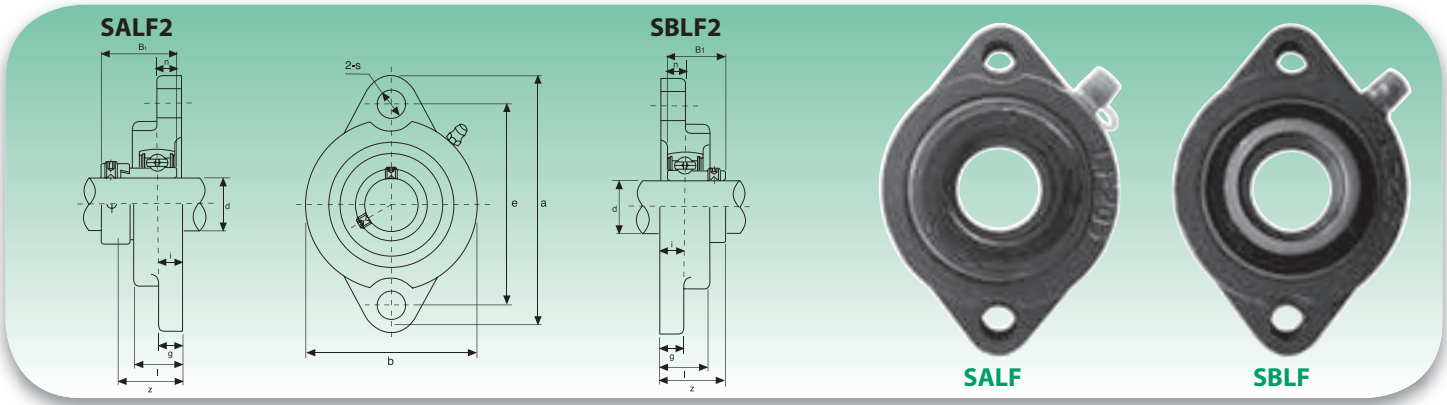

Tipo Type	Dimensioni - Dimensions								Bull. fiss. Bolt Size	SALF			Cuscinetto Bearing	Peso Weight	SBLF			Cuscinetto Bearing	Peso Weight	Supporto Housing	Coefficienti di carico (N) Load ratings (N)	
	d	a	e	b	i	s	g	l		z	B ₁	n			z	B ₁	n				Dinamico C Dynamic C	Statico C ₀ Static C ₀
	mm/inch									mm/inch					mm/inch							
SALF-SBLF 201 201-8	12 ½	81 33/16	63,5 2½	56 2 1/8	9,5 3/8	8 5/16	9,5 3/8	18 45/64	M6 ¼	31,6 1¼	28,6 1,1260	6,5 0,2559	SA201 SA201-8	0,3 1	25,5 0,8661	22 0,2362	6	SB201 SB201-8	0,3	LF203	9200	4480
SALF-SBLF 202 202-9 202-10	15 9/16 5/8	81 33/16	63,5 2½	56 2 1/8	9,5 3/8	8 5/16	9,5 3/8	18 45/64	M6 ¼	31,6 1¼	28,6 1,1260	6,5 0,2559	SA202 SA202-9 SA202-10	0,3 1	25,5 0,8661	22 0,2362	6	SB202 SB202-9 SB202-10	0,3	LF203	9200	4480
SALF-SBLF 203 203-11	17 11/16	81 33/16	63,5 2½	56 2 1/8	9,5 3/8	8 5/16	9,5 3/8	18 45/64	M6 ¼	31,6 1¼	28,6 1,1260	6,5 0,2559	SA203 SA203-11	0,3 1	25,5 0,8661	22 0,2362	6	SB203 SB203-11	0,3	LF203	9200	4480
SALF-SBLF 204 204-12	20 ¾	90 35/64	71,5 2 13/64	61 2 13/64	11 7/16	10 25/64	11 7/16	20 25/32	M8 5/16	34,5 1 23/64	31 1,2204	7,5 0,2953	SA204 SA204-12	0,4 19/64	29 0,9843	25 0,2756	7	SB204 SB204-12	0,3	LF204	12200	6300
SALF-SBLF 205 205-13 205-14 205-15 205-16	25 13/16 7/8 15/16 1	95 3 3/4	76 2 3/64	64 2 3/64	11 7/16	10 25/64	11 7/16	20 25/32	M8 5/16	34,5 1 23/64	31 1,2204	7,5 0,2953	SA205 SA205-13 SA205-14 SA205-15 SA205-16	0,5 113/64	30,5 1,0630	27 0,2953	7,5	SB205 SB205-13 SB205-14 SB205-15 SB205-16	0,4	LF205	13300	7460
SALF-SBLF 206 206-17 206-18 206-19 205-20	30 11/16 11/8 13/16 1¼	113 47/16	90,5 39/16	76 3	12 15/32	12 15/32	12 15/32	22,5 57/64	M10 3/8	38,7 1 33/64	35,7 1,4055	9 0,3543	SA206 SA206-17 SA206-18 SA206-19 SA206-20	0,7 111/32	34 1,1811	30 0,3150	8	SB206 SB206-17 SB206-18 SB206-19 SB206-20	0,6	LF206	18500	10800
SALF-SBLF 207 207-20 207-21 207-22 205-23	35 1¼ 15/16 13/8 17/16	122 4 13/16	100 3 15/16	89 3 1/2	13 33/64	12 15/32	13 33/64	24 61/64	M10 3/8	42,4 1 43/64	38,9 1,5315	9,5 0,3740	SA207 SA207-20 SA207-21 SA207-22 SA207-23	0,9 17/16	36,5 1,2598	32 0,3346	8,5	SB207 SB207-20 SB207-21 SB207-22 SB207-23	0,8	LF207	24500	14600



d Ø	Dimensioni - Dimensions							Viti fissaggio Fixing bolts	Tipo cuscinetto Bearing type	Peso fusione kg Housing weight kg
	H	J	A2	A1	A	S	f h8			
	mm									
20	100	78	2	8	17	9	62	M8	GRAE 20	0,37
25	115	90	2,5	9	19	9	70	M8	GRAE 25	0,55
30	125	100	2	9,5	20,5	11,5	80	M10	GRAE 30	0,66
35	135	110	1	10	20,5	11,5	90	M10	GRAE 35	0,79
40	145	120	1	11,5	23	11,5	100	M10	GRAE 40	1
45	155	130	2	12	25	14	105	M12	GRAE 45	1,24
50	165	135	1	13	25	14	110	M12	GRAE 50	1,53
55	185	150	0	15	27,5	18	125	M16	GRAE 55	1,95
60	195	160	1	16	29	18	135	M16	GRAE 60	2,15

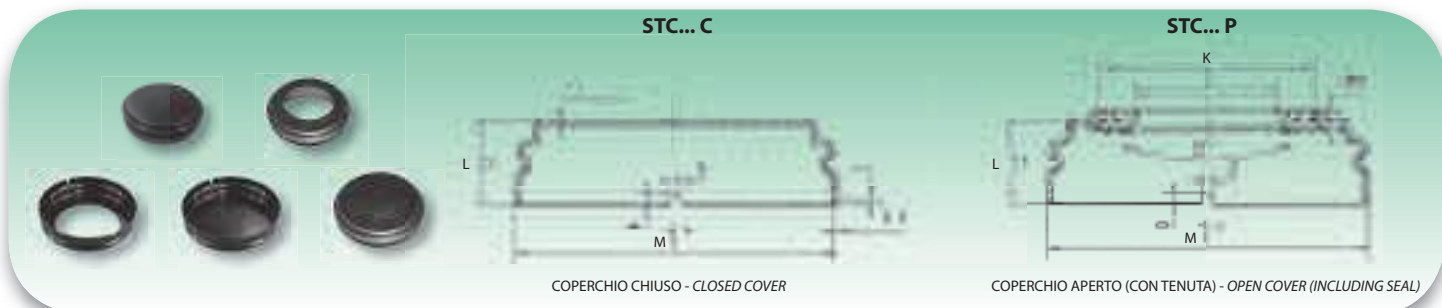

Tipo Type	Dimensioni - Dimensions					
	C	M	K	L	D	t
	mm					
STC204C	20	52	32	14,7	2,0	1,0
STC204P						
STC205C	25	58	38	15,5	2,0	1,0
STC205P						
STC206C	30	68	42	16,5	2,0	1,0
STC206P						
STC207C	35	78	48	19,5	2,5	1,0
STC207P						
STC208C	40	85,9	52	23,6	2,5	1,0
STC208P						
STC209C	45	91	57	24	2,5	1,0
STC209P						
STC210C	50	96	62	26	2,5	1,0
STC210P						
STC211C	55	108	67	25,5	2,5	1,0
STC211P						
STC212C	60	120	72	31,5	2,5	1,0
STC212P						
STC218C	90	168	102	40	2,5	1,0
STC218P						

I coperti sono disponibili su richiesta - Covers are available under request

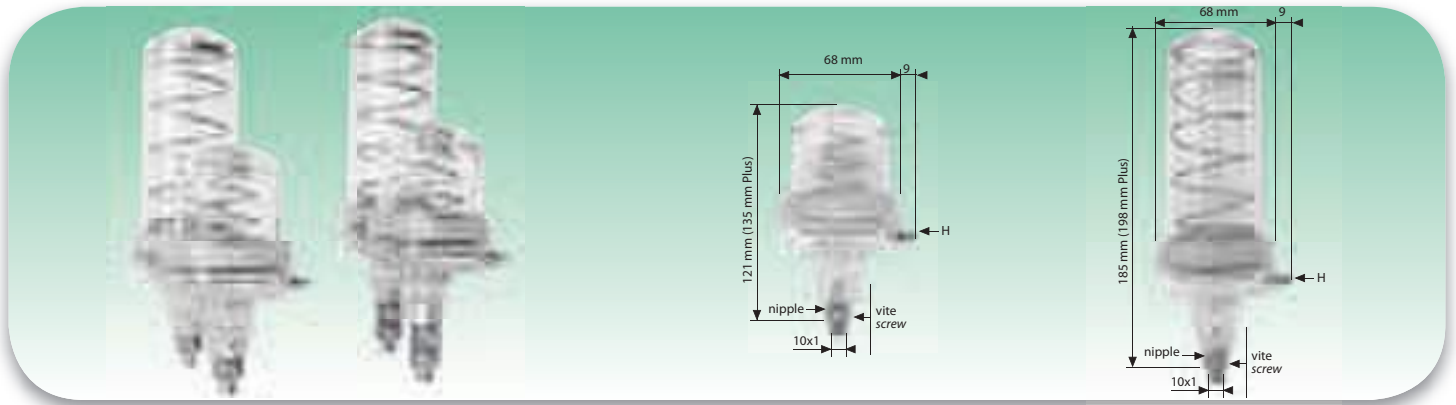

Gli ingrassatori e oliatori ISB sono costruiti in Lexan® trasparente, un materiale plastico ad alta resistenza meccanica, chimica e termica; questa soluzione permette di visualizzare il consumo del lubrificante in qualsiasi momento. All'interno delle capsule in Lexan® è presente una molla che permette di attivare immediatamente gli ingrassatori e oliatori ISB, che non necessitano quindi di energia elettrica o gas per funzionare; il flusso di lubrificante è sempre costante, senza accumuli solidi, ottenendo così un forte risparmio in termini di fermi di produzione ed eventuali riparazioni. Gli ingrassatori e gli oliatori ISB possono essere ricaricati più volte tramite l'ingrassatore laterale H (su richiesta disponibile in versione DE); essi sono installabili ovunque ci sia un punto da lubrificare (cuscinetti, boccole, snodi ecc).

The ISB greasers and oilers are made of transparent Lexan®, a plastic material with high mechanical, chemical and thermal resistance; this solution allows to control the consumption of the lubricant at any time. Inside the Lexan® capsules there is a spring that allows an immediate activation of the ISB greasers and oilers, so they do not need any electrical energy or gas to operate; the lubricant flow remains constant, with no solid matter accumulation and consequently there is an high saving in terms of production stops and possible repairs. The ISB greasers and oilers can be refilled more times from side lubricator H (under request the DE side lubricator is available); they can be installed wherever a point to be lubricated is present (bearings, bushes, joints etc).

Caratteristiche tecniche - Technical characteristics

Tipo Type	Capacità Capacity	Temperatura di utilizzo Temperature of application	Durata erogazione lubrificante Lubricant supply duration	Intensità fuoriuscita lubrificante Lubricant emission intensity	Molla Spring	Consistenza lubrificante Lubricant consistency
	ml	°C	mesi months			
INGRASSATORE ISB ISB GREASER	100/220	-30/+132	1,3,6,12	...	*D,M,F	NLGI 0-1-2-3-4
OLIATORE ISB ISB OILER	100/220	-30/+132	1,3,6,12	...	*D,M,F	NLGI 0-1-2-3-4
INGRASSATORE ISB PLUS ISB GREASER PLUS	100/220	-30/+132	1,3,6,12	**L,M,H	Unica	NLGI 0-1-2-3-4

* M: Molla media standard - Standard medium spring.

D: Molla debole per alta temperatura e/o grasso fluido (disponibile su richiesta) - Light spring for high temperature and/or fluid grease (available under request).

F: Molla forte per bassa temperatura e/o grasso denso (disponibile su richiesta) - Strong spring for low temperature and/or dense grease (available under request).

** L: Leggera - Light

M: Media - Medium

H: Alta - High



ADATTATORI (disponibili su richiesta)
ADAPTERS (available under request)



ESEMPIO DI APPLICAZIONE
APPLICATION EXAMPLE

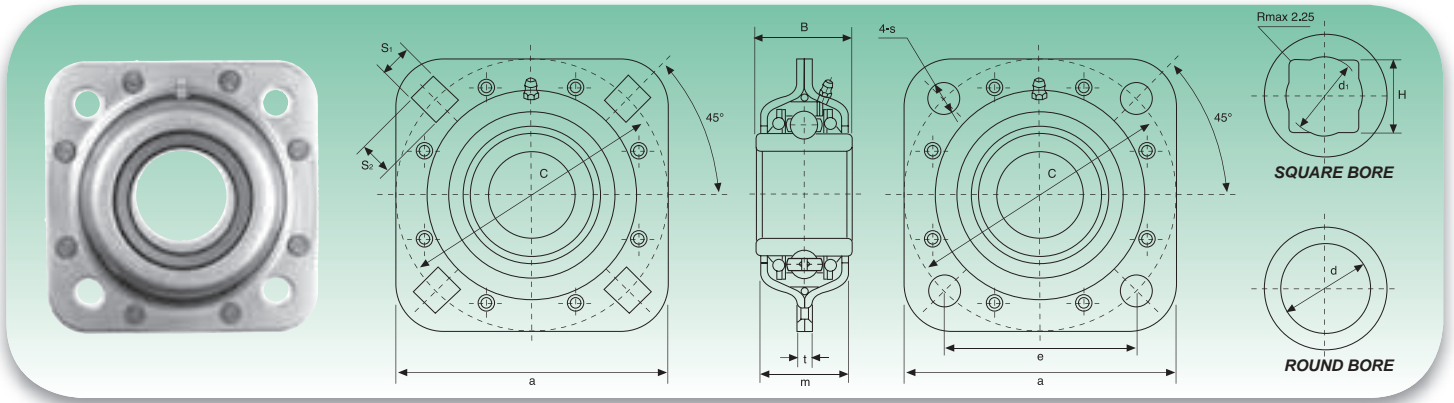

Tipo Type	Dimensioni - Dimensions												Coefficienti di carico (N) Load ratings (N)	
	H	d	a	B	m	t	C	s	s ₁	s ₂	d ₁	e	Dinamico C Dynamic C	Statico C ₀ Static C ₀
	mm/inch													
ST209-1½	29,972	-	127	42,8	42	6	127	13,5	13,5	17,45	32,0	-	24360	17710
ST209-30S	31,353	-	127	42,8	42	6	127	13,5	13,5	17,45	34,5	-	24360	17710
ST209-1¼	32,766	-	127	42,8	42	6	127	13,5	13,5	17,45	34,5	-	24360	17710
ST491B	-	38,860	127	42,8	42	6	127	13,5	13,5	17,45	-	-	24360	17710
ST209-40R	-	40,878	127	42,8	42	6	127	13,5	13,5	17,45	-	-	24360	17710
ST491A	-	45,000	127	42,8	42	6	127	13,5	13,5	17,45	-	90	24360	17710
ST209-45R	-	45,340	127	42,8	42	6	127	13,5	13,5	17,45	-	-	24360	17710
ST491A¹⁾	-	45,000	121	46	42	6	121	13,5	-	-	-	85	24360	17710
ST211-1½	38,890	-	139,7	50,8	46	8	139,7	13,5	13,5	17,45	42,0	-	33370	25110
ST211-40S	40,878	-	139,7	50,8	46	8	139,7	13,5	13,5	17,45	43,1	-	33370	25110
ST211-50R	-	50,400	139,7	50,8	46	8	139,7	13,5	13,5	17,45	-	-	33370	25110
ST211-55R	-	55,575	139,7	50,8	46	8	139,7	13,5	13,5	17,45	-	-	33370	25110
ST211-1¾	-	45,212	139,7	55,6	46	8	139,7	13,5	13,5	17,45	-	-	33370	25110
ST211-2¾/16	-	55,575	139,7	55,6	46	8	139,7	13,5	13,5	17,45	-	-	33370	25110
ST211-1¹⁵/₁₆	-	49,238	139,7	69,9	46	8	139,7	13,5	13,5	17,45	-	-	33370	25110
ST211	-	55,000	139,7	55,6	46	8	139,7	13,5	13,5	17,45	-	-	33370	25110
ST740	-	55,562	139,7	55,6	45	7	139,7	13,5	13,5	17,45	-	98	33370	25110

¹⁾ Dimensioni speciali - Special dimensions

Disponibile su richiesta con fori di fissaggio quadrati - Available on request with square fixing holes

BPP2-SA - BPP2-SB Serie leggera - Light duty

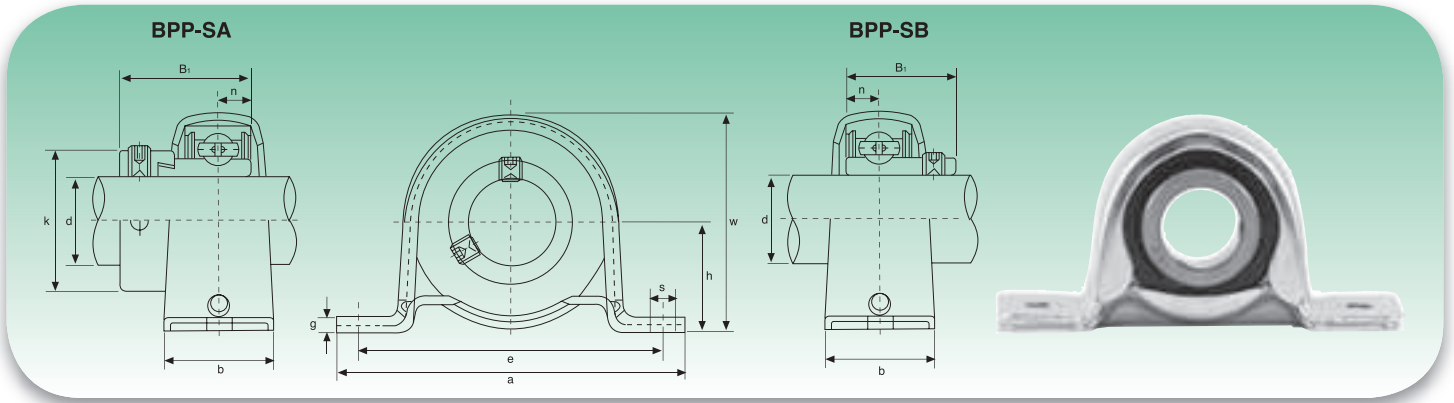

Tipo Type	Dimensioni - Dimensions								Bull. fiss. Bolt Size	BPP-SA		Cuscinetto Bearing	Peso Weight	BPP-SB		Cuscinetto Bearing	Peso Weight	Supporto Housing	Coefficienti di carico (N) Load ratings (N)	
	d	h	a	e	b	s	g	w		B ₁	n			B ₁	n				Dinamico C Dynamic C	Statico C ₀ Static C ₀
	mm/inch									mm/inch				mm/inch					kg	
BPP-SA BPP-SB 201 201-8	12 ½	22,2 7/8	86 33/8	68 2 3/4	25 1 3/4	9,5 3/8	3,2 1/8	43,8 1 3/4	M8 5/16	28,6 1,1260	6,5 0,2559	SA201 SA201-8	0,19	22 0,8661	6 0,2362	SB201 SB201-8	0,19	PP203	9200	4480
BPP-SA BPP-SB 202 202-9 202-10	15 9/16 5/8	22,2 7/8	86 33/8	68 2 3/4	25 1 3/4	9,5 3/8	3,2 1/8	43,8 1 3/4	M8 5/16	28,6 1,1260	6,5 0,2559	SA202 SA202-9 SA202-10	0,19	22 0,8661	6 0,2362	SB202 SB202-9 SB202-10	0,19	PP203	9200	4480
BPP-SA BPP-SB 203 203-11	17 1 1/16	22,2 7/8	86 33/8	68 2 3/4	25 1 3/4	9,5 3/8	3,2 1/8	43,8 1 3/4	M8 5/16	28,6 1,1260	6,5 0,2559	SA203 SA203-11	0,19	22 0,8661	6 0,2362	SB203 SB203-11	0,19	PP203	9200	4480
BPP-SA BPP-SB 204 204-12	20 ¾	25,4 1	98 3 7/8	76 2 9/8	32 1 ¼	9,5 3/8	3,2 1/8	50,6 1 9/8	M8 5/16	31 1,2204	7,5 0,2953	SA204 SA204-12	0,23	25 0,9843	7 0,2756	SB204 SB204-12	0,23	PP204	12200	6300
BPP-SA BPP-SB 205 205-13 205-14 205-15 205-16	25 1 3/16 7/8 15/16 1	28,6 1 1/8	108 4 1/4	86 3 1/4	32 1 ¼	11,5 29/64	4 0,157	56,6 2 1/8	M10 3/8	31 1,2204	7,5 0,2953	SA205 SA205-13 SA205-14 SA205-15 SA205-16	0,32	27 1,0630	7,5 0,2953	SB205 SB205-13 SB205-14 SB205-15 SB205-16	0,28	PP205	13300	7460
BPP-SA BPP-SB 206 206-17 206-18 206-19 206-20	30 1 1/16 1 1/8 13/16 1 ¼	33,3 1 1/8	117 4 3/8	95 3 7/8	38 1 ½	11,5 29/64	4 0,157	66,3 2 5/8	M10 3/8	35,7 1,4055	9 0,3543	SA206 SA206-17 SA206-18 SA206-19 SA206-20	0,50	30 1,1811	8 0,3150	SB206 SB206-17 SB206-18 SB206-19 SB206-20	0,47	PP206	18500	10800
BPP-SA BPP-SB 207 207-20 207-21 207-22 207-23	35 1 ¼ 15/16 13/8 17/16	39,7 1 5/8	129 5 1/8	106 4 1/4	42 1 1/2	11,5 29/64	4,6 0,181	78 3 1/8	M10 3/8	38,9 1,5315	9,5 0,3740	SA207 SA207-20 SA207-21 SA207-22 SA207-23	0,71	32 1,2598	8,5 0,3346	SB207 SB207-20 SB207-21 SB207-22 SB207-23	0,57	PP207	24500	14600
BPP-SA BPP-SB 208 208-24 208-25	40 1 ½ 19/16	43,7 1 7/8	148 5 7/8	120 4 11/16	43 1 7/8	12 0,196	5 3/16	86,5 3 3/8	M10 3/8	43,7 1,721	11 0,4331	SA208 SA208-24 SA208-25	0,95	34 1,3386	9 0,3543	SB208 SB208-24 SB208-25	0,80	PP208	27700	17000

Disponibile in acciaio inox Supporto: AISI 304 - Cuscinetto: AISI 440C o 420C - Available stainless steel Housing: AISI 304 - Bearing: AISI 440C or 420C

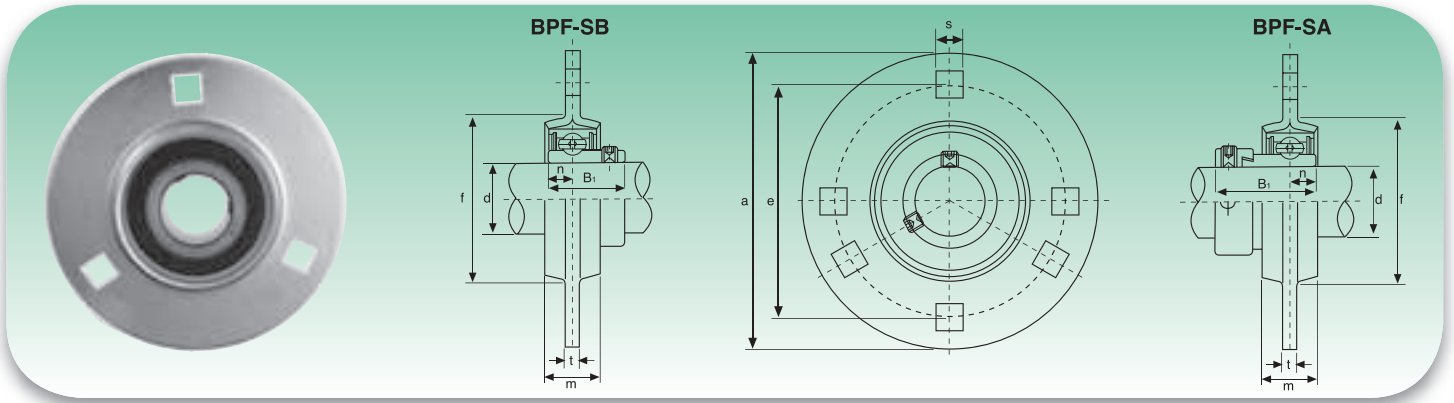

Tipo Type	Dimensioni - Dimensions								Bull. fiss. Bolt Size	BPF-SA		Cuscinetto Bearing	Peso Weight	BPF-SB		Cuscinetto Bearing	Peso Weight	Supporto Housing	Coefficienti di carico (N) Load ratings (N)	
	d	a	e	m	s	t	f(min)	B ₁		n	B ₁			n	Dinamico C Dynamic C				Statico C ₀ Static C ₀	
	mm/inch									mm/inch				mm/inch						
BPF-SA BPF-SB 201 201-8	12 ½	81 33/16	63,5 2½	14 9/16	7,1 9/32	4 0,157	49 159/64	M6 ¼	28,6 1,1260	6,5 0,2559	SA201 SA201-8	0,3	22 0,8661	6 0,2362	SB201 SB201-8	0,27	PF203	9200	4480	
BPF-SA BPF-SB 202 202-9 202-10	15 9/16 5/8	81 33/16	63,5 2½	14 9/16	7,1 9/32	4 0,157	49 159/64	M6 ¼	28,6 1,1260	6,5 0,2559	SA202 SA202-9 SA202-10	0,3	22 0,8661	6 0,2362	SB202 SB202-9 SB202-10	0,27	PF203	9200	4480	
BPF-SA BPF-SB 203 203-11	17 11/16	81 33/16	63,5 2½	14 9/16	7,1 9/32	4 0,157	49 159/64	M6 ¼	28,6 1,1260	6,5 0,2559	SA203 SA203-11	0,3	22 0,8661	6 0,2362	SB203 SB203-11	0,27	PF203	9200	4480	
BPF-SA BPF-SB 204 204-12	20 ¾	90 335/64	71,5 2 13/16	16 5/8	9 23/64	4 0,157	56 213/64	M8 5/16	31 1,2204	7,5 0,2953	SA204 SA204-12	0,33	25 0,9843	7 0,2756	SB204 SB204-12	0,33	PF204	12200	6300	
BPF-SA BPF-SB 205 205-13 205-14 205-15 205-16	25 13/16 7/8 15/16 1	95 3 3/4	76 253/64	18 23/32	9 223/64	4 0,157	60 223/64	M8 5/16	31 1,2204	7,5 0,2953	SA205 SA205-13 SA205-14 SA205-15 SA205-16	0,42	27 1,0630	7,5 0,2953	SB205 SB205-13 SB205-14 SB205-15 SB205-16	0,38	PF205	13300	7460	
BPF-SA BPF-SB 206 206-17 206-18 206-19 206-20	30 11/16 11/8 13/16 1¼	113 47/16	90,5 3 9/16	18 23/32	11 7/16	5,2 0,205	71 251/64	M10 3/8	35,7 1,4055	9 0,3543	SA206 SA206-17 SA206-18 SA206-19 SA206-20	0,65	30 1,1811	8 0,3150	SB206 SB206-17 SB206-18 SB206-19 SB206-20	0,62	PF206	18500	10800	
BPF-SA BPF-SB 207 207-20 207-21 207-22 207-23	35 1¼ 15/16 13/8 17/16	122 4 1/8	100 3 15/16	20 25/32	11 7/16	5,2 0,205	81 33/16	M10 3/8	38,9 1,5315	9,5 0,3740	SA207 SA207-20 SA207-21 SA207-22 SA207-23	0,9	32 1,2598	8,5 0,3346	SB207 SB207-20 SB207-21 SB207-22 SB207-23	0,82	PF207	24500	14600	
BPF-SA BPF-SB 208 208-24 208-25	40 1½ 19/16	148 5 13/16	119 4 11/16	21 13/16	13,5 17/32	6,8 0,268	91 337/64	M12 ½	43,7 1,7205	11 0,4331	SA208 SA208-24 SA208-25	1,15	34 1,3386	9 0,3543	SB208 SB208-24 SB208-25	1,1	PF208	27700	17000	

Disponibile in acciaio inox Supporto: AISI 304 - Cuscinetto: AISI 440C o 420C - Available stainless steel Housing: AISI 304 - Bearing: AISI 440C or 420C.

BPFL2-SA - BPFL2-SB Serie leggera - Light duty

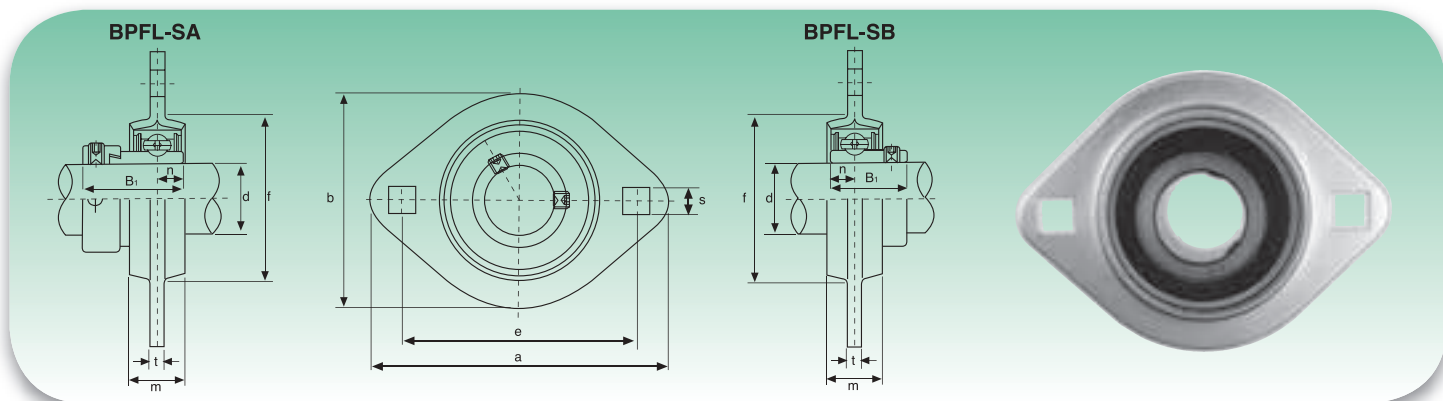

Tipo Type	Dimensioni - Dimensions								Bull. fiss. Bolt Size	BPFL-SA		Cuscinetto Bearing	Peso Weight	BPFL-SB		Cuscinetto Bearing	Peso Weight	Supporto Housing	Coefficienti di carico (N) Load ratings (N)	
	d	a	e	b	m	s	t	f(min)		B ₁	n			B ₁	n				Dinamico C Dynamic C	Statico C ₀ Static C ₀
	mm/inch									mm/inch				mm/inch					kg	
BPFL-SA BPFL-SB 201 201-8	12 ½	81 33/16	63,5 2½	59 221/64	14 9/16	7,1 159/64	4 0,157	49 159/64	M6 ¼	28,6 1,1260	6,5 0,2559	SA201 SA201-8	0,22	22 0,8661	6 0,2362	SB201 SB201-8	0,19	PFL203	9200	4480
BPFL-SA BPFL-SB 202 202-9 202-10	15 9/16 5/8	81 33/16	63,5 2½	59 221/64	14 9/16	7,1 159/64	4 0,157	49 159/64	M6 ¼	28,6 1,1260	6,5 0,2559	SA202 SA202-9 SA202-10	0,22	22 0,8661	6 0,2362	SB202 SB202-9 SB202-10	0,19	PFL203	9200	4480
BPFL-SA BPFL-SB 203 203-11	17 11/16	81 33/16	63,5 2½	59 221/64	14 9/16	7,1 159/64	4 0,157	49 159/64	M6 ¼	28,6 1,1260	6,5 0,2559	SA203 SA203-11	0,22	22 0,8661	6 0,2362	SB203 SB203-11	0,19	PFL203	9200	4480
BPFL-SA BPFL-SB 204 204-12	20 ¾	90 35/64	71,5 213/16	67 241/64	16 5/8	9 23/64	4 0,157	56 213/64	M8 5/16	31 1,2204	7,5 0,2953	SA204 SA204-12	0,24	25 0,9843	7 0,2756	SB204 SB204-12	0,24	PFL204	12200	6300
BPFL-SA BPFL-SB 205 205-13 205-14 205-15 205-16	25 13/16 7/8 15/16 1	95 3¾	76 253/64	71 251/64	18 23/32	9 23/64	4 0,157	60 223/64	M8 5/16	31 1,2204	7,5 0,2953	SA205 SA205-13 SA205-14 SA205-15 SA205-16	0,32	27 1,0630	7,5 0,2953	SB205 SB205-13 SB205-14 SB205-15 SB205-16	0,28	PFL205	13300	7460
BPFL-SA BPFL-SB 206 206-17 206-18 206-19 206-20	30 11/16 11/8 13/16 1¼	113 47/16	90,5 39/16	84 1635/16	18 23/32	11 7/16	5,2 0,205	71 251/64	M10 3/8	35,7 1,4055	9 0,3543	SA206 SA206-17 SA206-18 SA206-19 SA206-20	0,41	30 1,1811	8 0,3150	SB206 SB206-17 SB206-18 SB206-19 SB206-20	0,38	PFL206	18500	10800
BPFL-SA BPFL-SB 207 207-20 207-21 207-22 207-23	35 1¼ 15/16 13/8 17/16	122 413/16	100 315/16	94 345/64	20 25/32	11 7/16	5,2 0,205	81 33/16	M10 3/8	38,9 1,5315	9,5 0,3740	SA207 SA207-20 SA207-21 SA207-22 SA207-23	0,52	32 1,2598	8,5 0,3346	SB207 SB207-20 SB207-21 SB207-22 SB207-23	0,50	PFL207	24500	14600
BPFL-SA BPFL-SB 208 208-24 208-25	40 1½ 19/16	148 513/16	119 411/16	100 16315/16	21 13/16	13,5 17/32	6,8 0,268	91 337/64	M12 ½	43,7 1,7205	11 0,4331	SA208 SA208-24 SA208-25	0,83	34 1,3386	9 0,3543	SB208 SB208-24 SB208-25	0,80	PFL208	27700	17000

Disponibile in acciaio inox Supporto: AISI 304 - Cuscinetto: AISI 440C o 420C - Available stainless steel Housing: AISI 304 - Bearing: AISI 440C or 420C.

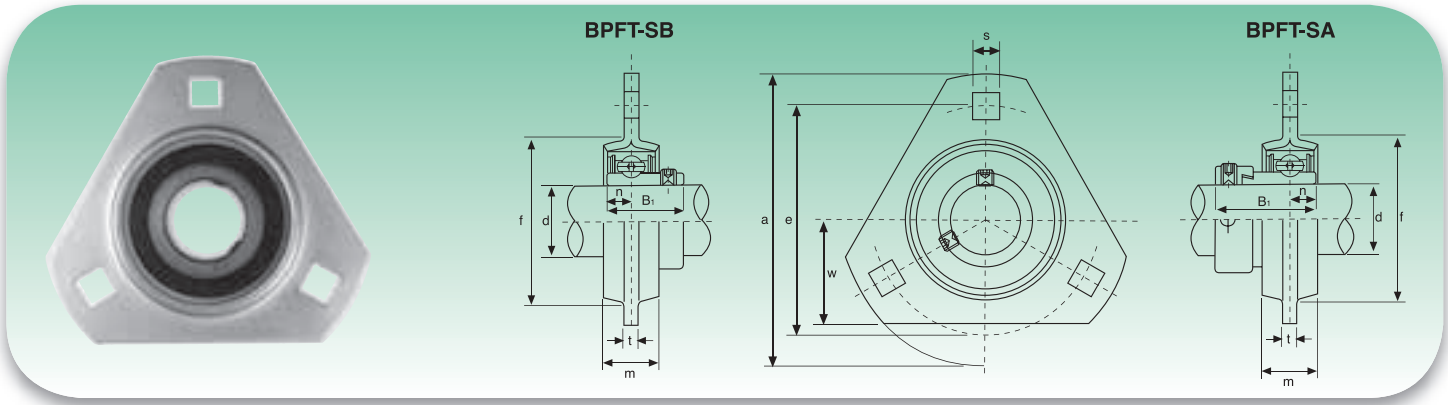

Tipo Type	Dimensioni - Dimensions								Bull. fiss. Bolt Size	BPFT-SA		Cuscinetto Bearing	Peso Weight	BPFT-SB		Cuscinetto Bearing	Peso Weight	Supporto Housing	Coefficienti di carico (N) Load ratings (N)	
	d	a	e	w	m	s	t	f _(min)		B ₁	n			B ₁	n				Dinamico C Dynamic C	Statico C ₀ Static C ₀
	mm/inch									mm/inch				mm/inch					kg	
BPFT-SA BPFT-SB 201 201-8	12 ½	81 33/16	63,5 2½	28,5 11/8	14 9/16	7,1 9/32	4 0,157	49 159/64	M6 ¼	28,6 1,1260	6,5 0,2559	SA201 SA201-8	0,26	22 0,8661	6 0,2362	SB201 SB201-8	0,23	PFT203	9200	4480
BPFT-SA BPFT-SB 202 202-9 202-10	15 9/16 5/8	81 33/16	63,5 2½	28,5 11/8	14 9/16	7,1 9/32	4 0,157	49 159/64	M6 ¼	28,6 1,1260	6,5 0,2559	SA202 SA202-9 SA202-10	0,26	22 0,8661	6 0,2362	SB202 SB202-9 SB202-10	0,23	PFT203	9200	4480
BPFT-SA BPFT-SB 203 203-11	17 11/16	81 33/16	63,5 2½	28,5 11/8	14 9/16	7,1 9/32	4 0,157	49 159/64	M6 ¼	28,6 1,1260	6,5 0,2559	SA203 SA203-11	0,26	22 0,8661	6 0,2362	SB203 SB203-11	0,23	PFT203	9200	4480
BPFT-SA BPFT-SB 204 204-12	20 ¾	90 35/64	71,5 2 13/16	33 1 19/64	16 5/8	9 23/64	4 0,157	56 213/64	M8 5/16	31 1,2204	7,5 0,2953	SA204 SA204-12	0,28	25 0,9843	7 0,2756	SB204 SB204-12	0,28	PFT204	12200	6300
BPFT-SA BPFT-SB 205 205-13 205-14 205-15 205-16	25 13/16 7/8 15/16 1	95 3 3/4	76 2 33/64	35 1 13/8	18 23/32	9 23/64	4 0,157	60 223/64	M8 5/16	31 1,2204	7,5 0,2953	SA205 SA205-13 SA205-14 SA205-15 SA205-16	0,36	27 1,0630	7,5 0,2953	SB205 SB205-13 SB205-14 SB205-15 SB205-16	0,36	PFT205	13300	7460
BPFT-SA BPFT-SB 206 206-17 206-18 206-19 206-20	30 11/16 11/8 13/16 1¼	113 47/16	90,5 3 9/16	40 1 137/64	18 23/32	11 7/16	5,2 0,205	71 251/64	M10 3/8	35,7 1,4055	9 0,3543	SA206 SA206-17 SA206-18 SA206-19 SA206-20	0,58	30 1,1811	8 0,3150	SB206 SB206-17 SB206-18 SB206-19 SB206-20	0,55	PFT206	18500	10800
BPFT-SA BPFT-SB 207 207-20 207-21 207-22 207-23	35 1¼ 15/16 13/8 17/16	122 4 13/16	100 3 15/16	44,5 1 3/4	20 25/32	11 7/16	5,2 0,205	81 33/16	M10 3/8	38,9 1,5315	9,5 0,3740	SA207 SA207-20 SA207-21 SA207-22 SA207-23	0,82	32 1,2598	8,5 0,3346	SB207 SB207-20 SB207-21 SB207-22 SB207-23	0,74	PFT207	24500	14600
BPFT-SA BPFT-SB 208 208-24 208-25	40 1½ 19/16	148 5 13/16	119 4 11/16	55 2 1/8	23 29/32	13,5 0,531	5,8 0,228	85 3,646	M15 7/16	43,7 1,7201	11 0,4331	SA208 SA208-24 SA208-25	1,05	34 -	9 0,3543	SB208 SB208-24 SB208-25	0,90	PFT208	27700	17000

Disponibile in acciaio inox Supporto: AISI 304 - Cuscinetto: AISI 440C o 420C - Available stainless steel Housing: AISI 304 - Bearing: AISI 440C or 420C.

CUSCINETTI

BEARING



SUPPORTI RITTI IN DUE METÀ

PLUMMER BLOCKS



SUPPORTI FLANGIATI

HOUSINGS



SUPPORTI IN PLASTICA

PLASTIC BEARING UNITS

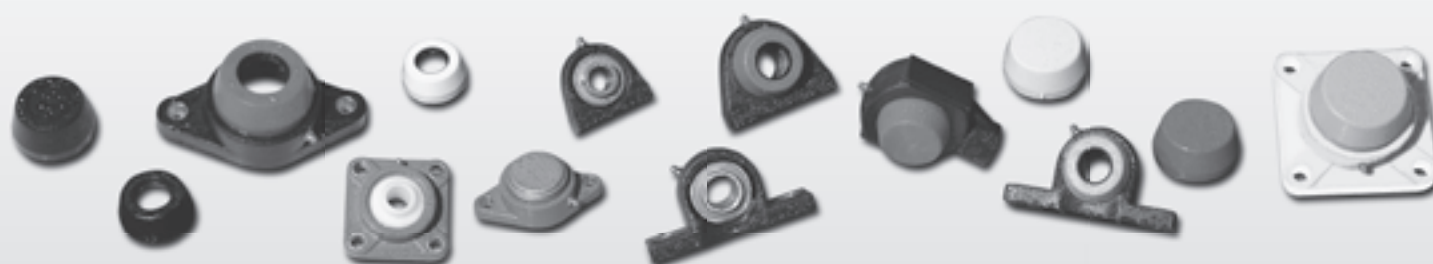

SUPPORTI PER VITI A RICIRCOLO DI SFERE

SUPPORTS OF BALL SCREWS

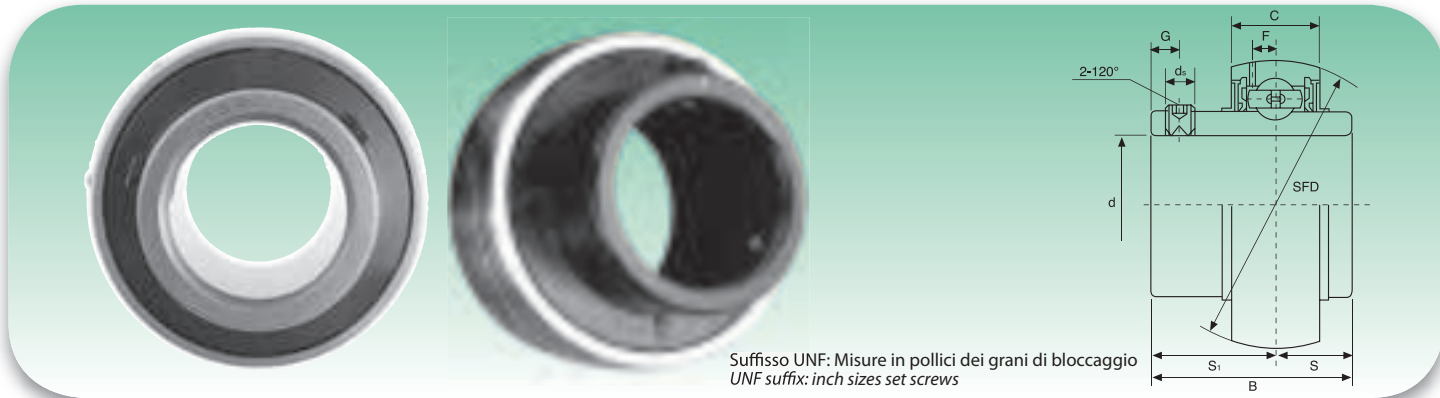

UC2 Serie normale - Standard duty

Suffisso UNF: Misure in pollici dei grani di bloccaggio
UNF suffix: inch sizes set screws

Tipo Type	Dimensioni - Dimensions									Coefficients di carico (N) Load ratings (N)		Peso Weight kg
	d	D	B	C	S	S ₁	G	ds	F	Dinamico C Dynamic C	Statico C ₀ Static C ₀	
	mm/inch											
UC201 UC201-8	12 ½	47 1,8504	31 1,2205	17 0,6693	12,7 0,500	18,3 0,720	4,8 0,189	M6x1 ¼-28UNF	3,7 0,146	12160	6318	0,20 0,19
UC202 UC202-9 UC202-10	15 9/16 5/8	47 1,8504	31 1,2205	17 0,6693	12,7 0,500	18,3 0,720	4,8 0,189	M6x1 ¼-28UNF	3,7 0,146	12160	6318	0,19 0,19 0,19
UC203 UC203-11	17 11/16	47 1,8504	31 1,2205	17 0,6693	12,7 0,500	18,3 0,720	4,8 0,189	M6x1 ¼-28UNF	3,7 0,146	12160	6318	0,18 0,17
*UC204 UC204-12	20 ¾	47 1,8504	31 1,2205	17 0,6693	12,7 0,500	18,3 0,720	4,8 0,189	M6x1 ¼-28UNF	3,7 0,146	12160	6318	0,16 0,16
*UC205 UC205-13 UC205-14 UC205-15 UC205-16	25 13/16 7/8 15/16 1	52 2,0472	34,1 1,3425	17 0,6693	14,3 0,563	19,8 0,780	5 0,197	M6x1 ¼-28UNF	3,9 0,154	13300	7457	0,20 0,24 0,23 0,21 0,20
*UC206 UC206-17 UC206-18 UC206-19 UC206-20	30 11/16 11/8 13/16 1¼	62 2,4409	38,1 1,5000	19 0,7480	15,9 0,626	22,2 0,874	5 0,197	M6x1 ¼-28UNF	5,0 0,197	18525	10735	0,32 0,33 0,34 0,32 0,31
*UC207 UC207-20 UC207-21 UC207-22 UC207-23	35 1¼ 15/16 13/8 17/16	72 2,8346	42,9 1,6890	20 0,7874	17,5 0,689	25,4 1,000	7 0,276	M8x1 5/16-24UNF	5,7 0,224	24415	14630	0,48 0,54 0,51 0,48 0,45
*UC208 UC208-24 UC208-25	40 1½ 19/16	80 3,1496	49,2 1,9370	21 0,8268	19 0,748	30,2 1,189	8 0,315	M8x1 5/16-24UNF	6,2 0,244	27645	16910	0,64 0,68 0,65
*UC209 UC209-26 UC209-27 UC209-28	45 15/8 111/16 1¾	85 3,3465	49,2 1,9370	22 0,8661	19 0,748	30,2 1,189	8 0,315	M8x1 5/16-24UNF	6,4 0,252	32395	20235	0,68 0,78 0,74 0,70
*UC210 UC210-29 UC210-30 UC210-31 UC210-32	50 113/16 17/8 115/16 2	90 3,5433	51,6 2,0315	24 0,9449	19 0,748	32,6 1,283	10 0,394	M10x1 3/8-24UNF	6,5 0,256	33345	22135	0,80 0,92 0,87 0,82 0,78
*UC211 UC211-32 UC211-33 UC211-34 UC211-35	55 2 21/16 21/8 23/16	100 3,9370	55,6 2,1890	25 0,9843	22,2 0,874	33,4 1,315	10 0,394	M10x1 3/8-24UNF	7,0 0,276	41230	27930	1,11 1,26 1,20 1,15 1,09
*UC212 UC212-36 UC212-37 UC212-38 UC212-39	60 2¼ 25/16 23/8 27/16	110 4,3307	65,1 2,5630	27 1,0630	25,4 1,000	39,7 1,563	10 0,394	M10x1 3/8-24UNF	7,6 0,299	49780	34390	1,54 1,67 1,59 1,52 1,45
UC213 UC213-40 UC213-41	65 2½ 29/16	120 4,7244	65,1 2,5630	28 1,1024	25,4 1,000	39,7 1,563	10 0,394	M10x1 3/8-24UNF	8,5 0,335	54340	38095	1,85 1,94 1,85
UC214 UC214-42 UC214-43 UC214-44	70 25/8 211/16 2¾	125 4,9213	74,6 2,9370	29 1,1417	30,2 1,189	44,4 1,748	12 0,472	M12x1,5 7/16-20UNF	8,9 0,350	59090	41895	2,05 2,26 2,16 2,06
UC215 UC215-45 UC215-46 UC215-47 UC215-48	75 213/16 27/8 215/16 3	130 5,1181	77,8 3,0630	30 1,1811	33,3 1,311	44,5 1,752	12 0,472	M12x1,5 7/16-20UNF	9,2 0,362	64030	45885	2,21 2,46 2,35 2,24 2,12
UC216 UC216-49 UC216-50 UC216-51	80 31/16 31/8 33/16	140 5,5118	82,6 3,2520	32 1,2598	33,3 1,311	49,3 1,9409	12 0,472	M12x1,5 7/16-20UNF	9,5 0,374	69065	50350	2,80 2,98 2,85 2,72
UC217 UC217-52 UC217-53 UC217-55	85 3¼ 35/16 37/16	150 5,9055	85,7 3,3740	34 1,3386	34,1 1,343	51,6 2,031	12 0,472	M12x1,5 7/16-20UNF	10,2 0,402	79800	58805	3,46 3,68 3,54 3,25
UC218 UC218-56	90 3½	160 6,2992	96 3,7795	36 1,4173	39,7 1,5630	56,3 2,217	12 0,472	M12x1,5 7/16-20UNF	11,2 0,441	91295	67925	4,36 4,47

Disponibile in acciaio inox AISI 440C o 420C - Available stainless steel AISI 440C or 420C

*Fornito con schermo antipolvere a stella, grano con sfera e anello interno brunito - Equipped with anti-rust shield star shape, screw with ball and burnished inner ring

HC2 Serie normale - Standard duty

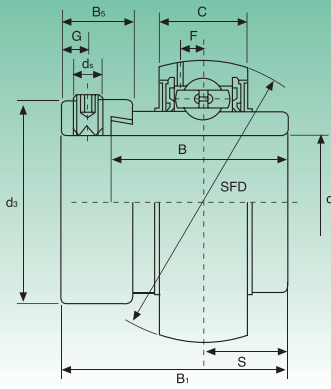

Suffisso UNF: Misure in pollici dei grani di bloccaggio
UNF suffix: inch sizes set screws

Tipo Type	Dimensioni - Dimensions											Coefficienti di carico (N) Load ratings (N)		Peso Weight kg
	d	D	B ₁	B	C	S	d _s	G	B _s	d ₃	F	Dinamico C Dynamic C	Statico C ₀ Static C ₀	
	mm/inch													
HC204	20	47	43,7	34,2	17	17,1	M6x1	4,8	13,5	33,3	3,7	12160	6318	0,23
HC204-12	¾	1,8504	1,720	1,3465	0,6693	0,673	¼-28UNF	0,189	0,531	1,311	0,146			0,23
HC205	25	52	44,4	34,9	17	17,5	M6x1	4,8	13,5	38,1	3,9	13300	7457	0,27
HC205-13	13/16													0,32
HC205-14	7/8	2,0472	1,748	1,3740	0,6693	0,689	¼-28UNF	0,189	0,531	1,500	0,154			0,31
HC205-15	15/16													0,29
HC205-16	1													0,27
HC206	30	62	48,4	36,5	19	18,3	M8x1	6	15,9	44,5	5,0	18525	10735	0,45
HC206-17	11/16													0,50
HC206-18	11/8	2,4409	1,906	1,4370	0,7480	0,720	5/16-24UNF	0,236	0,626	1,752	0,197			0,47
HC206-19	13/16													0,45
HC206-20	1¼													0,42
HC207	35	72	51,1	37,6	20	18,8	M8x1	6,8	17,5	55,6	5,7	24415	14630	0,60
HC207-20	1¼													0,67
HC207-21	15/16	2,8346	2,012	1,4803	0,7874	0,740	5/16-24UNF	0,268	0,689	2,189	0,224			0,63
HC207-22	13/8													0,60
HC207-23	17/16													0,57
HC208	40	80	56,3	42,8	21	21,4	M8x1	6,8	18,3	60,3	6,2	27645	16910	0,79
HC208-24	1½	3,1496	2,217	1,6850	0,8268	0,843	5/16-24UNF	0,268	0,720	2,374	0,244			0,84
HC208-25	19/16													0,80
HC209	45	85	56,3	42,8	22	21,4	M8x1	6,8	18,3	63,5	6,4	32395	20235	0,85
HC209-26	15/8													0,96
HC209-27	111/16	3,3465	2,217	1,6850	0,8661	0,843	5/16-24UNF	0,268	0,720	2,5000	0,252			0,91
HC209-28	1¾													0,87
HC210	50	90	62,7	49,2	24	24,6	M8x1	6,8	18,3	69,9	6,5	33345	22135	0,99
HC210-29	113/16													1,14
HC210-30	17/8	3,5433	2,469	1,9370	0,9449	0,969	5/16-24UNF	0,268	0,720	2,752	0,256			1,08
HC210-31	115/16													1,02
HC210-32	2													0,96
HC211	55	100	71,4	55,5	25	27,8	M10x1	8	20,7	76,2	7,0	41230	27930	1,32
HC211-32	2													1,52
HC211-33	21/16	3,9370	2,811	2,1850	0,9843	1,094	3/8-24UNF	0,315	0,815	3,000	0,276			1,44
HC211-34	21/8													1,37
HC211-35	23/16													1,29
HC212	60	110	77,8	61,9	27	31	M10x1	8	22,3	84,2	7,6	49780	34390	1,88
HC212-36	2¼													2,04
HC212-37	25/16	4,3307	3,063	2,4370	1,0630	1,220	3/8-24UNF	0,315	0,878	3,315	0,299			1,95
HC212-38	23/8													1,90
HC212-39	27/16													1,77
HC213	65	120	85,7	68,6	28	34,1	M10x1	8,5	23,5	86	8,5	54340	38095	2,41
HC213-40	2½	4,7244	3,374	2,7008	1,1024	1,343	3/8-24UNF	0,335	0,925	3,386	0,335			2,51
HC213-41	29/16													2,40
HC214	70	125	85,7	68,6	29	34,1	M10x1	8,5	23,5	90	8,9	59090	41895	2,55
HC214-42	25/8													2,79
HC214-43	211/16	4,9213	3,374	2,7008	1,1417	1,343	3/8-24UNF	0,335	0,925	3,543	0,350			2,68
HC214-44	2¾													2,56
HC215	75	130	92,1	75	30	37,3	M10x1	8,5	23,5	102	9,2	64030	45885	2,84
HC215-45	213/16													3,14
HC215-46	27/8	5,1181	3,626	2,9528	1,1811	1,469	3/8-24UNF	0,335	0,925	4,016	0,362			3,01
HC215-47	215/16													2,88
HC215-48	3													2,74

Disponibile in acciaio inox AISI 440C o 420C - Available stainless steel AISI 440C or 420C

UCX Serie media - Medium duty

Suffisso UNF: Misure in pollici dei grani di bloccaggio
UNF suffix: inch sizes set screws

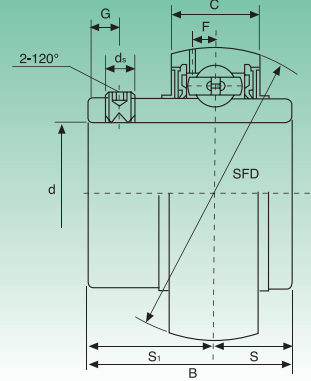

Tipo Type	Dimensioni - Dimensions									Coefficienti di carico (N) Load ratings (N)		Peso Weight kg
	d	D	B	C	S	S ₁	G	ds	F	Dinamico C Dynamic C	Statico C ₀ Static C ₀	
	mm/inch											
UCX05	25	62	38,1	19	15,9	22,2	5	M6x1	5,0			
UCX05-13	13/16											
UCX05-14	7/8	2,4409	1,5000	0,7480	0,626	0,874	0,197	¼-28UNF	0,197	18525	10735	0,39
UCX05-15	15/16											
UCX05-16	1											
UCX06	30	72	42,9	20	17,5	25,4	7	M8x1	5,7			
UCX06-17	11/16											
UCX06-18	11/8	2,8346	1,6890	0,7874	0,689	1,000	0,276	5/16-24UNF	0,224	24415	14630	0,68
UCX06-19	13/16											
UCX06-20	1¼											
UCX07	35	80	49,2	21	19	30,2	8	M8x1	6,2			
UCX07-21	15/16											
UCX07-22	13/8	3,1496	1,9370	0,8268	0,748	1,189	0,315	5/16-24UNF	0,244	27645	16910	0,82
UCX07-23	17/16											
UCX08	40	85	49,2	22	19	30,2	8	M8x1	6,4			
UCX08-24	1½											
UCX08-25	19/16	3,3465	1,9370	0,8661	0,748	1,189	0,315	5/16-24UNF	0,252	32395	20235	0,93
UCX09	45	90	51,6	24	19	32,6	10	M10x1	6,5			
UCX09-26	15/8											
UCX09-27	111/16	3,5433	2,0315	0,9449	0,748	1,283	0,394	3/8-24UNF	0,256	33345	22135	1,00
UCX09-28	1¾											
UCX10	50	100	55,6	25	22,2	33,4	10	M10x1	7,0			
UCX10-30	17/8											
UCX10-31	115/16	3,9370	2,1890	0,9843	0,874	1,315	0,394	3/8-24UNF	0,276	41230	27930	1,35
UCX10-32	2											
UCX11	55	110	65,1	27	25,4	39,7	10	M10x1	7,6			
UCX11-33	21/16											
UCX11-34	21/8	4,3307	2,5630	1,0630	1,000	1,563	0,394	3/8-24UNF	0,299	49780	34390	1,90
UCX11-35	23/16											
UCX11-36	2¼											
UCX12	60	120	65,1	28	25,4	39,7	10	M10x1	8,5			
UCX12-38	23/8											
UCX12-39	27/16	4,7244	2,5630	1,1024	1,000	1,563	0,394	3/8-24UNF	0,335	54340	38095	2,27
UCX13	65	125	74,6	29	30,2	44,4	12	M12x1,5	8,9			
UCX13-40	2½											
UCX13-41	29/16	4,9213	2,9370	1,1417	1,189	1,748	0,472	7/16-20UNF	0,350	59090	41895	2,45
UCX14	70	130	77,8	30	33,3	44,5	12	M12x1,5	9,2			
UCX14-42	25/8											
UCX14-43	211/16	5,1181	3,0630	1,1811	1,311	1,752	0,472	7/16-20UNF	0,362	64030	45885	2,47
UCX14-44	2¾											
UCX15	75	140	82,6	32	33,3	49,3	12	M12x1,5	9,5			
UCX15-45	213/16											
UCX15-46	27/8	5,5118	3,2520	1,2598	1,311	1,9409	0,472	7/16-20UNF	0,374	69065	50350	3,11
UCX15-47	215/16											
UCX15-48	3											
UCX16	80	150	85,7	34	34,1	51,6	12	M12x1,5	10,2			
UCX16-49	31/16											
UCX16-50	31/8	5,9055	3,3740	1,3386	1,343	2,031	0,472	7/16-20UNF	0,402	79800	58805	3,79
UCX16-51	33/16											
UCX17	85	160	96	36	39,7	56,3	12	M12x1,5	11,2			
UCX17-53	35/16											
UCX17-55	37/16	6,2992	3,7795	1,4173	1,5630	2,217	0,472	½-20UNF	0,441	91295	67925	4,82
UCX18	90	170	104	39	42,9	61,1	14	M14x1,5	10,5			
UCX18-56	37/16											
UCX18-57	3½	6,6929	4,0945	1,5354	1,689	2,406	0,511	9/16-18UNF	0,413	103550	77805	5,51
UCX20	100	190	117,5	44	49,2	68,3	16	M16x1,5	11,3			
UCX20-58	313/16											
UCX20-59	37/8											
UCX20-60	315/16	7,4803	4,6260	1,7323	1,937	2,689	0,630	5/8-18UNF	0,445	126350	99750	8,95
UCX20-61	4											
UCX20-62	4											
UCX20-64	4											

UC3 Serie pesante - Heavy duty

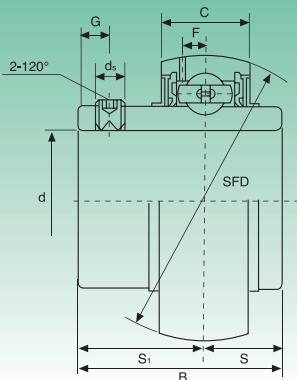

Suffisso UNF: Misure in pollici dei grani di bloccaggio
UNF suffix: inch sizes set screws

Tipo Type	Dimensioni - Dimensions									Coefficients di carico (N) Load ratings (N)		Peso Weight kg
	d	D	B	C	S	S ₁	G	ds	F	Dinamico C Dynamic C	Statico C ₀ Static C ₀	
	mm/inch											
UC305	25	62	38	20	15	23	6	M6x1	5,4			0,35
UC305-13	13/16											0,40
UC305-14	7/8											0,38
UC305-15	15/16	2,4409	1,4961	0,7874	0,591	0,906	0,236	¼-28UNF	0,213	20140	10355	0,36
UC305-16	1											0,35
UC306	30	72	43	23	17	26	6	M6x1	5,7			0,56
UC306-17	11/16											0,61
UC306-18	11/8	2,8346	1,6929	0,9055	0,669	1,024	0,236	¼-28UNF	0,225	25365	14250	0,58
UC306-19	13/16											0,56
UC307	35	80	48	25	19	29	8	M8x1	6,2			0,71
UC307-20	1¼											0,77
UC307-21	15/16	3,1496	1,8898	0,9843	0,748	1,142	0,315	5/16-24UNF	0,224	31730	18335	0,74
UC307-22	13/8											0,71
UC307-23	17/16											0,68
UC308	40	90	52	27	19	33	10	M10x1	7,0			0,96
UC308-24	1½											1,01
UC308-25	19/16	3,5433	2,0472	1,0630	0,748	1,299	0,394	3/8-24UNF	0,276	38665	22800	0,97
UC309	45	100	57	30	22	35	10	M10x1	7,8			1,28
UC309-26	15/8											1,39
UC309-27	111/16	3,9370	2,2441	1,1811	0,866	1,378	0,394	3/8-24UNF	0,307	46455	28025	1,35
UC309-28	1¾											1,30
UC310	50	110	61	32	22	39	12	M12x1,5	8,5			1,65
UC310-29	113/16											1,97
UC310-30	17/8	4,3307	2,4016	1,2598	0,866	1,535	0,472	7/16-20UNF	0,335	58900	36385	1,74
UC310-31	115/16											1,68
UC311	55	120	66	34	25	41	12	M12x1,5	9,2			2,07
UC311-32	2											2,25
UC311-33	21/16	4,7244	2,5984	1,3386	0,984	1,614	0,472	7/16-20UNF	0,362	68020	42750	2,18
UC311-34	21/8											2,12
UC311-35	23/16											2,04
UC312	60	130	71	36	26	45	12	M12x1,5	9,8			2,60
UC312-36	2¼											2,75
UC312-37	25/16	5,1181	2,7953	1,4173	1,0236	1,772	0,472	7/16-20UNF	0,386	77805	49590	2,67
UC312-38	23/8											2,58
UC312-39	27/16											2,50
UC313	65	140	75	38	30	45	12	M12x1,5	10,5			3,25
UC313-40	2½											3,34
UC313-41	29/16	5,5118	2,9528	1,4961	1,181	1,772	0,472	7/16-20UNF	0,413	88065	56905	3,24
UC314	70	150	78	40	33	45	12	M12x1,5	11,1			3,89
UC314-42	25/8											4,11
UC314-43	211/16	5,9055	3,0708	1,5748	1,299	1,772	0,472	7/16-20UNF	0,437	98800	64790	4,00
UC314-44	2¾											3,90
UC315	75	160	82	42	32	50	14	M14x1,5	11,8			4,72
UC315-45	213/16											4,99
UC315-46	27/8	6,2992	3,2283	1,6535	1,260	1,969	0,551	9/16-18UNF	0,465	107350	73340	4,85
UC315-47	215/16											4,76
UC315-48	3											4,63
UC316	80	170	86	44	34	52	14	M14x1,5	12,5			5,55
UC316-49	31/16											5,72
UC316-50	31/8	6,6929	3,3858	1,7323	1,339	2,047	0,551	9/16-18UNF	0,492	116850	82365	5,58
UC316-51	33/16											5,49
UC317	85	180	96	46	40	56	16	M16x1,5	13,1			6,67
UC317-52	3¾											6,89
UC317-53	35/16	7,0866	3,7795	1,8110	1,575	2,205	0,630	5/8-18UNF	0,516	126350	91960	6,76
UC317-55	37/16											6,44
UC318	90	190	96	48	40	56	16	M16x1,5	13,8			7,56
UC318-55	37/16											7,85
UC318-56	3½	7,4803	3,7795	1,8898	1,575	2,205	0,630	5/8-18UNF	0,543	135850	101650	7,67
UC319	95	200	103	50	41	62	16	M16x1,5	14,7			8,70
UC319-58	35/8											9,03
UC319-59	311/16	7,8740	4,0551	1,9685	1,614	2,441	0,630	5/8-18UNF	0,579	145350	113050	8,85
UC319-60	3¾											8,66
UC320	100	215	108	55	42	66	18	M18x1,5	13,5			10,80
UC320-61	313/16											11,20
UC320-62	37/8	8,4646	4,2520	2,1654	1,654	2,598	0,709	5/8-18UNF	0,531	164350	133950	10,98
UC320-63	315/16											10,80
UC320-64	4											10,60
UC321	105	225	112	56	44	68	18	M18x1,5	19,1	174800	145350	12,20
UC322	110	240	117	60	46	71	18	M18x1,5	20,6	194750	171000	14,30
UC324	120	260	126	64	51	75	18	M18x1,5	20,6	196650	175750	18,50
UC326	130	280	135	68	54	81	20	M20x1,5	22,2	217550	203300	23,00
UC328	140	300	145	73	59	86	22	M20x1,5	23,8	240350	233700	28,50

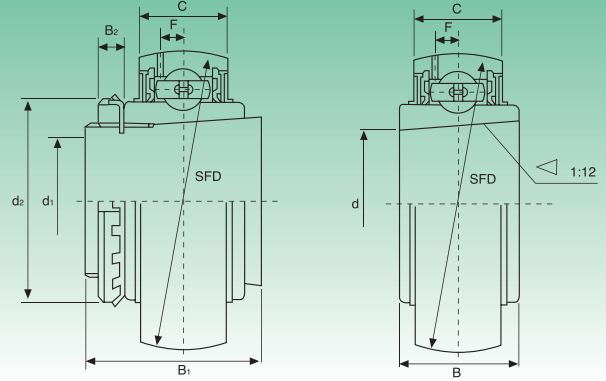
UK2 Serie normale - Standard duty

Tipo Type	Dimensioni - Dimensions									Coefficienti di carico (N) Load ratings (N)		Peso Weight kg
	d	D	B	C	d ₁	B ₁	B ₂	d ₂	F	Dinamico C Dynamic C	Statico C ₀ Static C ₀	
	mm/inch											
UK205+H2305	25	52	23	17	20	35	8	38	3,9	13300	7457	0,25
UK205+HE2305	0,9843	2,0472	0,9055	0,6693	¾	1,378	0,315	1,496	0,154			
UK206+H2306	30	62	26	19	25	38	8	45	5,0	18525	10735	0,36
UK206+HS2306	1,1811	2,4409	1,0236	0,7480	1	1,496	0,315	1,772	0,197			
UK207+H2307	35	72	29	20	30	43	9	52	5,7	24415	14630	0,57
UK207+HS2307	1,3780	2,8346	1,1417	0,7874	11/8	1,693	0,354	2,047	0,224			
UK208+H2308	40	80	31	21	35	46	10	58	6,2	27645	16910	0,74
UK208+HE2308	1,5748	3,1496	1,2205	0,8268	1¼	1,811	0,394	2,283	0,244			
UK209+H2309	45	85	31	22	40	50	11	65	6,4	32395	20235	0,83
UK209+HA2309					17/16							
UK209+HE2309	1,7717	3,3465	1,2205	0,8661	1½	1,969	0,433	2,559	0,252			
UK209+HS2309					15/8							
UK210+H2310	50	90	32	24	45	55	12	70	6,5	33345	22135	0,97
UK210+HS2310					15/8							
UK210+HA2310	1,9685	3,5433	1,2598	0,9449	111/16	2,165	0,472	2,756	0,256			
UK211+H2311	55	100	35	25	50	59	12	75	7,0	41230	27930	1,26
UK211+HS2311					17/8							
UK211+HA2311	2,1654	3,9370	1,3780	0,9843	115/16	2,323	0,472	2,953	0,276			
UK211+HE2311					2							
UK212+H2312	60	110	38	27	55	62	13	80	7,6	49780	34390	1,59
UK212+HS2312	2,3622	4,3307	1,4961	1,0630	21/8	2,441	0,512	3,150	0,299			
UK213+H2313	65	120	40	28	60	65	14	85	8,5	54340	38095	1,76
UK213+HA2313					23/16							
UK213+HE2313	2,5591	4,7244	1,5748	1,1024	2¼	2,559	0,551	3,346	0,335			
UK213+HS2313					23/8							
UK215+H2315	75	130	44	30	65	73	15	98	9,2	64030	45885	2,32
UK215+HA2315					27/16							
UK215+HE2315	2,9528	5,1181	1,7323	1,1811	2½	2,874	0,591	3,858	0,362			
UK216+H2316	80	140	45	32	70	78	17	105	9,5	69065	50350	3,06
UK216+HA2316					211/16							
UK216+HE2316	3,1496	5,5118	1,7717	1,2598	2¾	3,071	0,669	4,134	0,374			
UK217+H2317	85	150	46	34	75	82	18	110	10,2	79800	58805	3,88
UK217+HA2317					215/16							
UK217+HE2317	3,3465	5,9055	1,8110	1,3386	3	3,228	0,709	4,331	0,402			
UK218+H2318	90	160	47	36	80	86	18	120	11,2	91295	67925	4,74
UK218+HA2318	3,5433	6,2992	1,8504	1,4173	33/16	3,386	0,709	4,724	0,441			

Disponibile in acciaio inox AISI 440C o 420C - Available stainless steel AISI 440C or 420C
 Bussole HA; HE; HS con filettatura in pollici - Inch dimension adapter sleeves HA; HE; HS

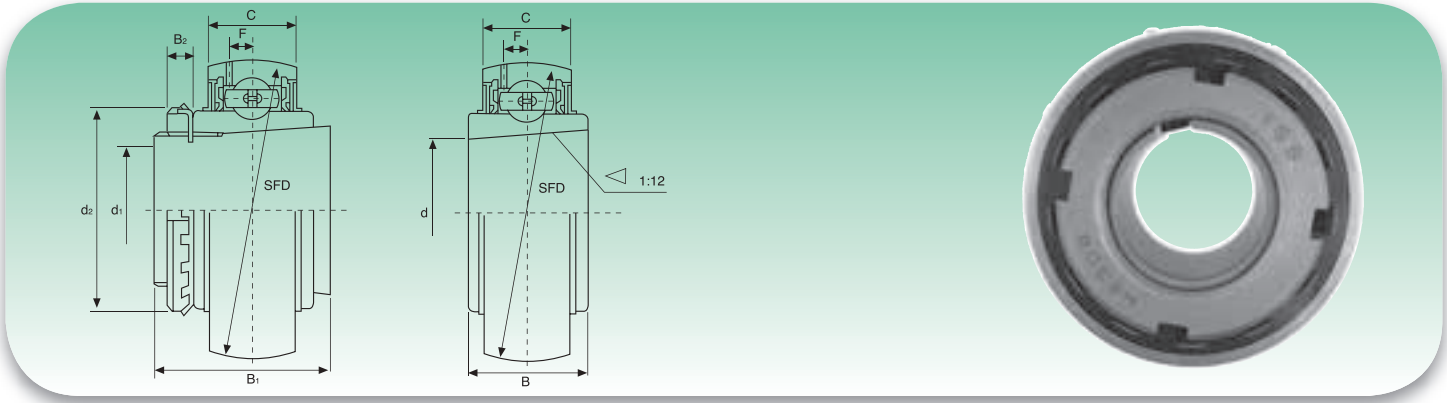

Tipo Type	Dimensioni - Dimensions									Coefficienti di carico (N) Load ratings (N)		Peso Weight kg
	d	D	B	C	d ₁	B ₁	B ₂	d ₂	F	Dinamico C Dynamic C	Statico C ₀ Static C ₀	
	mm/inch											
UKX05+H2305	25	62	26	19	20	35	8	38	5	18525	10735	0,37
UKX05+HE2305	0,9845	2,4409	1,0236	0,7480	¾	1,378	0,315	1,496	0,197			
UKX06+H2306	30	72	29	20	25	38	8	45	5,7	24415	14630	0,59
UKX06+HS2306	1,1811	2,8346	1,1417	0,7874	7/8	1,496	0,315	1,771	0,244			
UKX06+HE2306					1							
UKX07+H2307	35	80	31	21	30	43	9	52	6,2	27645	18910	0,75
UKX07+HS2307	1,3780	3,1496	1,2205	0,8268	11/8	1,693	0,354	2,047	0,244			
UKX08+H2308	40	85	31	22	35	46	10	58	6,4	32395	20235	0,86
UKX08+HE2308	1,5748	3,3465	1,2205	0,8661	1¼	1,811	0,394	2,284	0,252			
UKX08+HS2308					13/8							
UKX09+H2309	45	90	32	24	40	50	11	65	6,5	33345	22135	0,96
UKX09+HA2309	1,7717	3,5433	1,2598	0,9449	17/16	1,969	0,433	2,559	0,256			
UKX09+HE2309					1½							
UKX09+HS2309					15/8							
UKX10+H2310	50	100	35	25	45	55	12	70	7,0	41230	27930	1,34
UKX10+HS2310	1,9685	3,9370	1,3780	0,6843	15/8	2,165	0,472	2,756	0,726			
UKX10+HA2310					111/16							
UKX10+HE2310					1¾							
UKX11+H2311	55	100	38	27	50	59	12	75	7,6	49780	34390	1,67
UKX11+HS2311	2,1654	4,3307	1,496	1,0630	17/8	2,323	0,472	2,953	0,299			
UKX11+HA2311					115/16							
UKX11+HE2311					2							
UKX12+H2312	60	120	40	28	55	62	13	80	8,5	54340	38095	1,84
UKX12+HS2312	2,3622	4,7244	1,5748	1,1024	21/8	2,441	0,512	3,150	0,335			
UKX13+H2313	65	125	40	29	60	65	14	85	8,9	59090	41895	2,15
UKX13+HA2313	2,5591	4,9213	1,5748	1,1417	23/16	2,559	0,551	3,346	0,350			
UKX13+HE2313					2¼							
UKX13+HS2313					23/8							
UKX15+H2315	75	140	45	32	65	73	15	98	9,5	69065	50350	3,05
UKX15+HA2315	2,9528	5,5118	1,7717	1,2598	27/16	2,874	0,591	3,858	0,374			
UKX15+HS2315					2½							
UKX16+H2316	80	150	46	34	70	78	17	105	10,2	79800	58805	3,95
UKX16+HA2316	3,1496	5,9055	1,811	1,3386	211/16	3,071	0,669	4,134	0,402			
UKX16+HS2316					2¾							
UKX17+H2317	85	160	47	36	75	82	18	110	11,2	91295	67925	4,83
UKX17+HA2317	3,3465	6,2992	1,8504	1,4173	215/16	3,228	0,709	4,331	0,441			
UKX17+HE2317					3							
UKX18+H2318	90	170	52	39	80	86	18	120	12,5	103550	77805	5,45
UKX18+HA2318	3,5433	6,6929	1,9685	1,5354	33/16	3,386	0,709	4,724	0,492			

Bussolle HA; HE; HS con filettatura in pollici - Inch dimension adapter sleeves HA; HE; HS

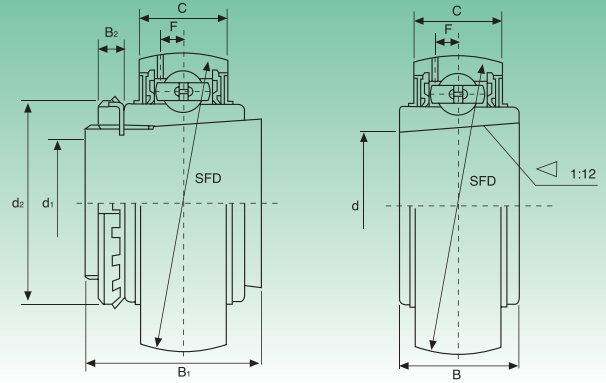
UK3 Serie pesante - Heavy duty

Tipo Type	Dimensioni - Dimensions									Coefficienti di carico (N) Load ratings (N)		Peso Weight kg
	d	D	B	C	d ₁	B ₁	B ₂	d ₂	F	Dinamico C Dynamic C	Statico C ₀ Static C ₀	
	mm/inch											
UK305+H2305	25	62	26	20	20	35	8	38	5,0	20140	10355	0,48
UC305+HE2305	0,9843	2,4409	1,0236	0,7874	¾	1,378	0,315	1,496	0,197			
UK306+H2306	30	72	29	23	25	38	8	45	5,9	25365	14250	0,59
UK306+HS2306	1,1811	2,8346	1,1417	0,9055	7/8	1,496	0,315	1,772	0,232			
UK306+HE2306					1							
UK307+H2307	35	80	33	25	30	43	9	52	6,8	31730	18335	0,76
UK307+HS2307	1,3780	3,1496	1,2992	0,9843	11/8	1,693	0,354	2,047	0,268			
UK308+H2308	40	90	34	27	35	46	10	58	7,4	38665	22800	1,07
UK308+HE2308	1,5748	3,5433	1,3386	1,0630	1¼	1,811	0,394	2,283	0,291			
UK308+HS2308					13/8							
UK309+H2309	45	100	37	29	40	50	11	65	7,4	46455	28025	1,31
UK309+HA2309	1,7717	3,9370	1,4567	1,1417	17/16	1,969	0,433	2,559	0,291			
UK309+HE2309					1½							
UK309+HS2309					15/8							
UK310+H2310	50	110	41	32	45	55	12	70	8,1	58900	36385	1,70
UK310+HS2310	1,9685	4,3307	1,6142	1,2598	15/8	2,165	0,472	2,756	0,319			
UK310+HA2310					111/16							
UK310+HE2310					1¾							
UK311+H2311	55	120	44	34	50	59	12	75	8,5	68020	42750	2,06
UK311+HS2311	2,1654	4,7244	1,7323	1,3386	17/8	2,323	0,472	2,953	0,335			
UK311+HA2311					115/16							
UK311+HE2311					2							
UK312+H2312	60	130	47	36	55	62	13	80	9	77805	49590	2,58
UK312+HS2312	2,3622	5,1181	1,8504	1,4173	21/8	2,441	0,512	3,150	0,354			
UK313+H2313	65	140	49	39	60	65	14	85	10,1	88065	56905	3,07
UK313+HA2313	2,5591	5,5118	1,9291	1,5354	23/16	2,559	0,551	3,346	0,398			
UK313+HE2313					2¼							
UK313+HS2313					23/8							
UK315+H2315	75	160	55	43	65	73	15	98	11	107350	73340	4,82
UK315+HA2315	2,9528	6,2992	2,1654	1,6929	27/16	2,874	0,591	3,858	0,433			
UK315+HE2315					2½							
UK316+H2316					80					170	58	45
UK316+HA2316	3,1496	6,6929	2,2835	1,7717	211/16	3,071	0,669	4,134	0,449			
UK316+HE2316					2¾							
UK317+H2317	85	180	60	47	75	82	18	110	12,0	126350	91960	6,47
UK317+HA2317	3,3465	7,0866	2,3622	1,8504	215/16	3,228	0,709	4,331	0,472			
UK317+HE2317					3							
UK318+H2318	90	190	64	49	80	86	18	120	12,3	135850	101650	7,52
UK318+HA2318	3,5433	7,4803	2,5197	1,9291	33/16	3,386	0,709	4,724	0,484			

Bussole HA; HE; HS con filettatura in pollici - Inch dimension adapter sleeves HA; HE; HS

SER2 Serie normale - Standard duty

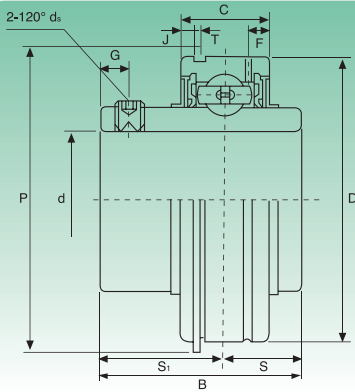

Suffisso UNF: Misure in pollici dei grani di bloccaggio
UNF suffix: inch sizes set screws

Tipo Type	Dimensioni - Dimensions												Coefficienti di carico (N) Load ratings (N)		Peso Weight kg
	d	D	B	C	S	S ₁	T	F	J	P	G	d _s	Dinamico C Dynamic C	Statico C ₀ Static C ₀	
	mm/inch														
SER204	20	47	31	15,9	10,3	20,7	1,12	3,8	2,46	52,7	4,8	M6x1	9880	6200	0,21
SER204-12	¾	1,8504	1,2205	0,6260	0,406	0,815	0,044	0,150	0,097	2,075	0,189	¼-28UNF			
SER205	25	52	34,9	19	13,1	21,8	1,12	5,2	2,46	57,9	5	M6x1	10780	6980	0,27
SER205-13	13/16	2,0472	1,3740	0,7480	0,516	0,858	0,044	0,205	0,097	2,280	0,197	¼-28UNF			
SER205-14	7/8														
SER205-15	15/16														
SER205-16	1														
SER206	30												62	38,1	22,2
SER206-17	11/16	2,4409	1,5000	0,8740	0,626	0,874	0,067	0,220	0,129	2,665	0,197	¼-28UNF			
SER206-18	11/8														
SER206-19	13/16														
SER206-20	1¼														
SER207	35												72	42,9	23,8
SER207-20	1¼	2,8346	1,6890	0,9370	0,689	1,000	0,067	0,220	0,129	3,094	0,264	5/16-24UNF			
SER207-21	15/16														
SER207-22	13/8														
SER207-23	17/16														
SER208	40												80	49,2	27,8
SER208-24	1½	3,1496	1,9370	1,0945	0,748	1,189	0,067	0,252	0,129	3,409	0,315	5/16-24UNF			
SER208-25	19/16														
SER209	45												85	49,2	27,8
SER209-26	15/8	3,3465	1,9370	1,0945	0,748	1,189	0,067	0,252	0,129	3,606	0,315	5/16-24UNF			
SER209-27	111/16														
SER209-28	1¾														
SER210	50												90	51,6	28,6
SER210-29	113/16	3,5433	2,0315	1,1260	0,748	1,283	0,097	0,295	0,129	3,799	0,394	3/8-24UNF			
SER210-30	17/8														
SER210-31	115/16														
SER210-32	2														
SER211	55												100	55,6	30,2
SER211-32	2	3,9370	2,1890	1,1890	0,874	1,315	0,097	0,295	0,129	4,193	0,394	3/8-24UNF			
SER211-33	21/16														
SER211-34	21/8														
SER211-35	23/16														
SER212	60												110	65,1	31,8
SER212-36	2¼	4,3307	2,5630	1,2520	1,000	1,563	0,097	0,295	0,129	4,591	0,394	3/8-24UNF			
SER212-37	25/16														
SER212-38	23/8														
SER212-39	27/16														

SA2 Serie leggera - Light duty

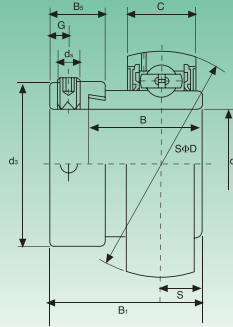

Suffisso UNF: Misure in pollici dei grani di bloccaggio
UNF suffix: inch sizes set screws

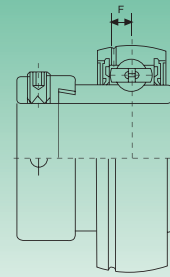

SA 2
anello esterno sferico
outer spherical ring

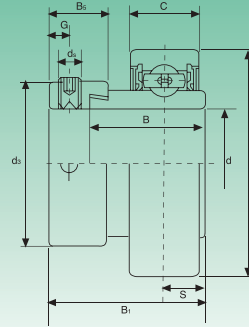

SA 2S
anello esterno sferico,
con gola di lubrificazione
outer spherical ring,
with relubrication groove



SA 2C
anello esterno cilindrico
outer cylindrical ring

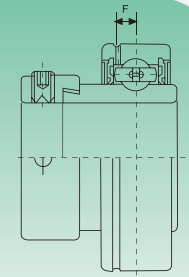

SA 2CS
anello esterno cilindrico,
con gola di lubrificazione
outer cylindrical ring,
with relubrication groove

Tipo Type	Dimensioni - Dimensions											Coefficienti di carico (N) Load ratings (N)		Peso Weight kg
	d	D	B ₁	B	C	S	d _s	G	B _s	d _s	F	Dinamico C Dynamic C	Statico C ₀ Static C ₀	
	mm/inch													
SA201	12	40	28,6	19,1	12	6,5	M6x1	4,8	13,5	28,6	3,7	9200	4480	0,12
SA201-8	½	1,5748	1,126	0,7520	0,4724	0,256	¼-28UNF	0,189	0,531	1,126	0,146			
SA202	15	40	28,6	19,1	12	6,5	M6x1	4,8	13,5	28,6	3,7	9200	4480	0,10
SA202-9	9/16	1,5748	1,126	0,7520	0,4724	0,256	¼-28UNF	0,189	0,531	1,126	0,146			
SA202-10	5/8													
SA203	17	40	28,6	19,1	12	6,5	M6x1	4,8	13,5	28,6	3,7	9200	4480	0,09
SA203-11	11/16	1,5748	1,126	0,7520	0,4724	0,256	¼-28UNF	0,189	0,531	1,126	0,146			
SA204	20	47	31	21,5	14	7,5	M6x1	4,8	13,5	33,3	3,7	12200	6300	0,16
SA204-12	¾	1,8504	1,220	0,8465	0,5512	0,295	¼-28UNF	0,189	0,531	1,311	0,146			
SA205	25	52	31	21,5	15	7,5	M6x1	4,8	13,5	38,1	3,9	13300	7460	0,20
SA205-13	13/16	2,0472	1,220	0,8465	0,5906	0,295	¼-28UNF	0,189	0,531	1,500	0,154			
SA205-14	7/8													
SA205-15	15/16													
SA205-16	1													
SA205-17	1 1/16													
SA206	30	62	35,7	23,8	16	9	M8x1	6	15,9	44,5	5,0	18500	10800	0,30
SA206-17	11/16	2,4409	1,406	0,9370	0,6299	0,354	5/16-28UNF	0,236	0,626	1,752	0,197			
SA206-18	11/8													
SA206-19	13/16													
SA206-20	1 ¼													
SA207	35	72	38,9	25,4	17	9,5	M8x1	6,8	17,5	55,6	5,7	24500	14600	0,42
SA207-20	1 ¼	2,8346	1,531	1,000	0,6693	0,374	5/16-24UNF	0,268	0,689	2,189	0,224			
SA207-21	15/16													
SA207-22	13/8													
SA207-23	17/16													
SA208	40	80	43,7	30,2	18	11	M8x1	6,8	18,3	60,3	6,2	27700	17000	0,60
SA208-24	1 ½	3,1496	1,721	1,1890	0,7087	0,433	5/16-24UNF	0,268	0,720	2,374	0,244			
SA208-25	19/16													
SA209	45	85	43,7	30,2	19	11	M8x1	6,8	18,3	63,5	6,4	31100	24450	0,76
SA209-26	15/8	3,3465	1,721	1,1890	0,7480	0,433	5/16-24UNF	0,268	0,720	2,500	0,252			
SA209-27	111/16													
SA209-28	1 ¾													
SA210	50	90	43,7	30,2	20	11	M8x1	6,8	18,3	69,9	6,5	35300	28160	0,91
SA210-29	113/16	3,5433	1,721	1,1890	0,7874	0,433	5/16-24UNF	0,268	0,720	2,752	0,256			
SA210-30	17/8													
SA210-31	115/16													
SA210-32	2													
SA211	55	100	48,4	32,5	21	12	M8x1	8	20,7	76,2	7,0	38100	30000	1,26
SA211-32	2	3,9370	1,906	1,2795	0,8268	0,472	5/16-24UNF	0,315	0,815	3,000	0,276			
SA211-33	21/16													
SA211-34	21/8													
SA211-35	23/16													
SA212	60	110	53,1	37,2	22	13,5	M10x1	8	22,3	84,2	7,6	41500	32730	1,70
SA212-36	2 ¼	4,3307	2,091	1,4646	0,8661	0,532	3/8-24UNF	0,315	0,878	3,315	0,299			
SA212-37	25/16													
SA212-38	23/8													
SA212-39	27/16													

Disponibile in acciaio inox AISI 440C o 420C - Available stainless steel AISI 440C or 420C

SB-RB2 Serie leggera - Light duty

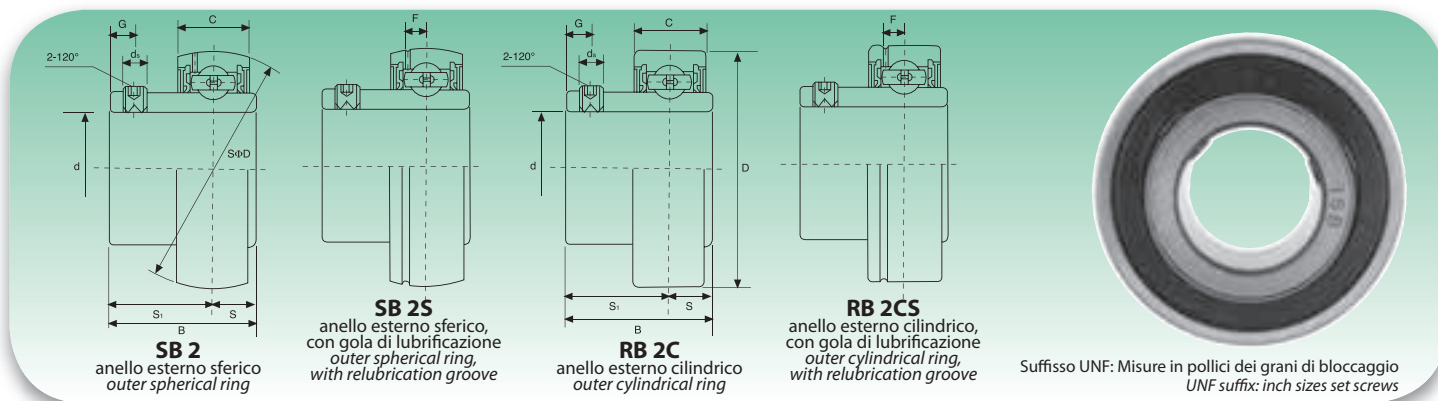

Tipo Type	Dimensioni - Dimensions									Coefficienti di carico (N) Load ratings (N)		Peso Weight kg
	d	D	B	C	S	S ₁	ds	G	F	Dinamico C Dynamic C	Statico C ₀ Static C ₀	
	mm/inch											
SB-RB201	12	40	22	12	6	16	M5x0,8	4,5	3,7	9200	4480	0,10
SB-RB201-8	½	1,5748	0,8661	0,4724	0,236	0,630	10-32UNF	0,177	0,146			
SB-RB202	15	40	22	12	6	16	M5x0,8	4,5	3,7	9200	4480	0,10
SB-RB202-9	9/16	1,5748	0,8661	0,4724	0,236	0,630	10-32UNF	0,177	0,146			
SB-RB202-10	5/8											
SB-RB203	17	40	22	12	6	16	M5x0,8	4,5	3,7	9200	4480	0,09
SB-RB203-11	11/16	1,5748	0,7520	0,4724	0,256	1/4-28UNF	0,189	0,531	0,146			
SB-RB204	20	47	25	14	7	18	M6x1	4,5	3,7	12200	6300	0,13
SB-RB204-12	¾	1,8504	0,9843	0,5512	0,276	0,709	¼-28UNF	0,177	0,146			
SB-RB205	25	52	27	15	7,5	19,5	M6x1	5,5	3,9	13300	7460	0,16
SB-RB205-13	13/16	2,0472	1,0630	0,5906	0,295	0,768	¼-28UNF	0,217	0,154			
SB-RB205-14	7/8											
SB-RB205-15	15/16											
SB-RB205-16	1											
SB-RB206	30	62	30	16	8	22	M6x1	6	5,0	18500	10800	0,25
SB-RB206-17	11/16	2,4409	1,1811	0,6299	0,315	0,866	¼-28UNF	0,236	0,197			
SB-RB206-18	11/8											
SB-RB206-19	13/16											
SB-RB206-20	1¼											
SB-RB207	35	72	32	17	8,5	23,5	M8x1	6,5	5,7	24500	14600	0,38
SB-RB207-20	1¼	2,8346	1,2598	0,6693	0,335	0,925	5/16-24UNF	0,256	0,224			
SB-RB207-21	15/16											
SB-RB207-22	13/8											
SB-RB207-23	17/16											
SB-RB208	40	80	34	18	9	25	M8x1	7	6,2	27700	17000	0,60
SB-RB208-24	1½	3,1496	1,3386	0,7087	0,354	0,984	5/16-24UNF	0,276	0,244			
SB-RB208-25	19/16											
SB-RB209	45	85	41,2	19	10,2	31	M8x1	8,2	6,4	31100	24450	0,8
SB-RB209-26	15/8	3,3465	1,6220	0,7480	0,402	1,220	5/16-24UNF	0,323	0,252			
SB-RB209-27	111/16											
SB-RB209-28	1¾											
SB-RB210	50	90	43,5	20	10,9	32,6	M10x1	9,2	6,5	35300	28160	0,8
SB-RB210-29	113/16	3,5433	1,7126	0,7874	0,429	1,283	3/8-24UNF	0,362	0,256			
SB-RB210-30	17/8											
SB-RB210-31	115/16											
SB-RB210-32	2											
SB-RB211	55	100	45,3	21	11,8	33,5	M10x1	9,8	7,0	38100	30000	1,1
SB-RB211-32	2	3,9370	1,7835	0,8268	0,465	1,319	3/8-24UNF	0,386	0,276			
SB-RB211-33	21/16											
SB-RB211-34	21/8											
SB-RB211-35	23/16											
SB-RB212	60	110	53,7	22	14,9	38,8	M10x1	9,8	7,6	41500	32730	1,3
SB-RB212-36	2¼	4,3307	2,1142	0,8661	0,587	1,528	3/8-24UNF	0,386	0,299			
SB-RB212-37	25/16											
SB-RB212-38	23/8											
SB-RB212-39	27/16											

Disponibile in acciaio inox AISI 440C o 420C - Available stainless steel AISI 440C or 420C

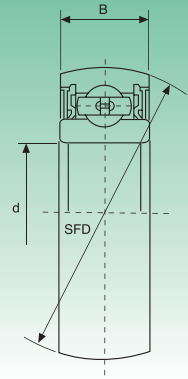

Tipo Type	Dimensioni - Dimensions			Coefficienti di carico (N) Load ratings (N)		Peso Weight
	d	D	B	Dinamico C Dynamic C	Statico C ₀ Static C ₀	
	mm/inch					kg
CB200	10	30	9	3750	2150	0,030
CB200	0,3937	1,1811	0,3543			
CB201	12	32	10	4500	2500	0,035
CB201	0,4724	1,2598	0,3937			
CB202	15	35	11	5650	3300	0,040
CB202	0,5906	1,3780	0,4331			
CB203	17	40	12	7000	4480	0,06
CB203	0,6693	1,5748	0,4724			
CB204	20	47	14	9880	6200	0,10
CB204	0,7874	1,8504	0,5512			
CB205	25	52	15	10780	6980	0,13
CB205	0,9843	2,0472	0,5906			
CB206	30	62	16	14970	10040	0,20
CB206	1,1811	2,4409	0,6299			
CB207	35	72	17	19750	13670	0,29
CB207	1,3780	2,8346	0,6693			
CB208	40	80	18	22710	15940	0,37
CB208	1,5748	3,1496	0,7087			
CB209	45	85	19	24360	17710	0,46
CB209	1,7717	3,3465	0,7480			
CB210	50	90	20	26980	19840	0,57
CB210	1,9685	3,5433	0,7874			
CB211	55	100	21	28500	21850	0,62
CB211	2,1654	3,9370	0,8268			
CB212	60	110	22	31700	24500	0,80
CB212	2,3622	4,3307	0,8661			

Equivalente serie 62.. bombato ISB® - Equivalent 62.. spherical ISB®

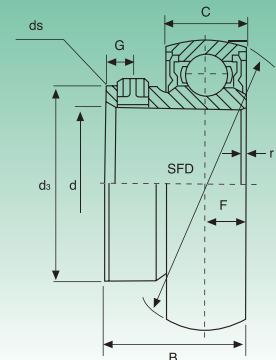

Tipo Type	Dimensioni - Dimensions									Coefficienti di carico (N) Load ratings (N)		Peso Weight
	d	D	B	C	d _s	F	G	r	ds	Dinamico C Dynamic C	Statico C ₀ Static C ₀	
	mm/inch											kg
U000	10	26	14	8	14,75	4	3	0,5	M3	4700	2000	0,023
U000	0,3937	1,024	0,5512	0,3150	0,5807	1,1575	0,1181	0,0197				
U001	12	28	14,5	8	17,35	4	3	0,5	M3	5200	2450	0,027
U001	0,4724	1,1024	0,5709	0,3150	0,6831	1,1575	0,1181	0,0197				
U002	15	32	16,5	9	20,02	4,5	3,5	0,5	M4	5700	2900	0,045
U002	0,5906	1,2598	0,6496	0,3543	0,7882	0,1772	0,1378	0,0197				
U003	17	35	17,5	10	23,10	5	3,5	0,5	M4	6100	3350	0,050
U003	0,6693	1,3780	0,6890	0,3937	0,9094	0,1969	0,1378	0,0197				
U004	20	42	21	12	27,00	6	4	1	M5	9550	5150	0,086
U004	0,7874	1,6535	0,8268	0,4724	1,0630	0,2362	1,1575	0,0394				
U005	25	47	22,5	12	31,70	6	4,5	1	M5	10300	5950	0,100
U005	0,9843	1,8504	0,8858	0,4724	1,2480	0,2362	0,1772	0,0394				
U006	30	55	24,5	13	38,00	6,5	5	1,5	M5	13500	8450	0,145
U006	1,1811	2,1654	0,9646	0,5118	1,4961	0,2559	0,1969	0,0591				

Disponibile su richiesta in acciaio inox: AISI 440C o 420C - Available under request stainless steel: AISI 440C or 420C

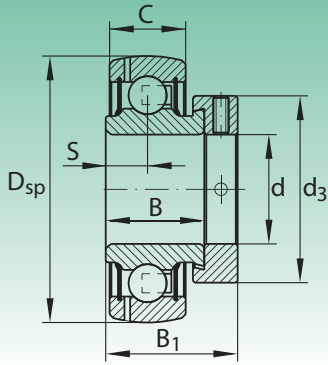

Tipo Type	Dimensioni - Dimensions							Coefficienti di carico Load ratings		Peso Weight
	d	Dsp	C	B	S	B1	d3 max	Dinamico Cr (kN) Dynamic Cr (kN)	Statico Cor (kN) Static Cor (kN)	
	mm									kg
GRAE 20 NPP-B	20	47	14	21,4	7,5	31	33	12,8	6,6	0,16
GRAE 25 NPP-B	25	52	15	21,4	7,5	31	37,5	14	7,8	0,19
GRAE 30 NPP-B	30	62	18	23,8	9	35,8	44	19,5	11,3	0,31
GRAE 35 NPP-B	35	72	19	25,4	9,5	39	51	25,5	15,3	0,48
GRAE 40 NPP-B	40	80	21	30,2	11	43,8	58	32,5	19,8	0,62
GRAE 45 NPP-B	45	85	22	30,2	11	43,8	63	32,5	20,4	0,69
GRAE 50 NPP-B	50	90	22	30,2	11	43,8	69	35	23,2	0,77
GRAE 55 NPP-B	55	100	25	32,5	12	48,4	76	43,5	29	0,81
GRAE 60 NPP-B	60	110	24	37,1	13,5	53,1	84	56	36	1,4

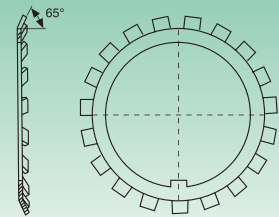
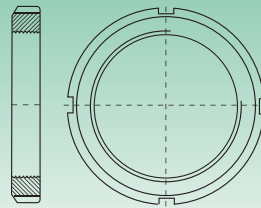
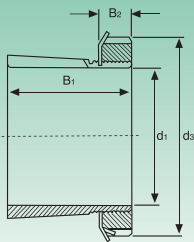

Tipo Type	Dimensioni - Dimensions				Bussola Sleeve	Ghiera di bloccaggio Lock nut	Rosetta Washer	Cuscinetto Bearing			Peso Weight			
	d ₁	B ₁	B ₂	d ₃				A...	KM	MB		Serie normale Normal duty	Serie media Medium duty	Serie pesante Heavy duty
	mm/inch													
H 2305	20	35	8	38	A 2305X	KM 05	MB 05	UK 205	UK X05	UK 305	0,087			
HE 2305	¾	1,3780	0,3150	1,4961	AE 2305X									
H 2306	25	38	8	45	A 2306X									
HS 2306	7/8				AS 2306X	KM 06	MB 06	UK 206	UK X06	UK 306	0,126			
HA 2306	15/16	1,4961	0,3150	1,7717	AA 2306X									
HE 2306	1				AE 2306X									
H 2307	30	43	9	52	A 2307X	KM 07	MB 07	UK 207	UK X07	UK 307	0,165			
HS 2307	11/8				AS 2307X									
HA 2307	13/16	1,6929	0,3543	2,0472	AA 2307X									
H 2308	35	46	10	58	A 2308X	KM 08	MB 08	UK 208	UK X08	UK 308	0,224			
HE 2308	1¼				AE 2308X									
HS 2308	13/8	1,8110	0,3937	2,2835	AS 2308X									
H 2309	40	50	11	65	A 2309X	KM 09	MB 09	UK 209	UK X09	UK 309	0,280			
HA 2309	17/16				AA 2309X									
HE 2309	1½	1,9685	0,4331	2,5591	AS 2309X									
H 2310	45	55	12	70	A 2310X	KM 10	MB 10	UK 210	UK X10	UK 310	0,362			
HA 2310	111/16				AA 2310X									
HE 2310	1¾	2,1654	0,4724	2,7559	AE 2310X									
H 2311	50	59	12	75	A 2311X	KM 11	MB 11	UK 211	UK X11	UK 311	0,420			
HS 2311	17/8				AS 2311X									
HA 2311	115/16	2,3228	0,4724	2,9528	AA 2311X									
HE 2311	2				AE 2311X									
H 2312	55	62	13	80	A 2312X	KM 12	MB 12	UK 212	UK X12	UK 312	0,480			
HS 2312	21/8	2,4409	0,5118	3,1496	AS 2312X									
H 2313	60	65	14	85	A 2313X									
HA 2313	23/16				AA 2313X	KM 13	MB 13	UK 213	UK X13	UK 313	0,556			
HE 2313	2¼	2,5591	0,5512	3,3465	AE 2313X									
HS 2313	23/8				AS 2313X									
H 2315	65	73	15	98	A 2315X	KM 15	MB 15	UK 215	UK X15	UK 315	1,05			
HE 2315	2½				AE 2315X									
HS 2315	25/8	2,8740	0,5906	3,8583	AS 2315X									
H 2316	70	78	17	105	A 2316X	KM 16	MB 16	UK 216	UK X16	UK 316	1,28			
HE 2316	2¾	3,0709	0,6693	4,1339	AE 2316X									
H 2317	75	82	18	110	A 2317X									
HS 2317	27/8				AS 2317X	KM 17	MB 17	UK 217	UK X17	UK 317	1,45			
HA 2317	215/16	3,2283	0,7087	4,3307	AA 2317X									
HE 2317	3				AE 2317X									
H 2318	80	86	18	120	A 2318X	KM 18	MB 18	UK 218	UK X18	UK 318	1,70			
HA 2318	33/16	3,3858	0,7087	4,7244	AA 2318X									
H 2319	85	90	19	125	A 2319X									
HE 2319	3¼	3,5433	0,7480	4,9213	AE 2319X	KM 19	MB 19	-	-	UK 319	1,94			
H 2320	90	97	20	130	A 2320X									
HE 2320	3½	3,8189	0,7874	5,1181	AE 2320X									
H 2322	100	105	21	145	A 2322X	KM 22	MB 22	-	-	UK 322	2,74			
HE 2322	4	4,1339	0,8268	5,7087	AE 2322X									
H 2324	110	112	22	155	A 2324X									
HA 2324	47/16	4,4094	0,8661	6,1024	AA 2324X	KM 24	MB 24	-	-	UK 324	3,20			
H 2326	115	121	23	165	A 2326X									
HE 2326	4½	4,7638	0,9055	6,4961	AE 2326X									
H 2328	125	131	24	180	A 2328X	KM 28	MB 28	-	-	UK 328	5,52			
HA 2328	415/16				AA 2328X									
HE 2328	51/8	5,1575	0,9449	7,0866	AE 2328X									





SNG 500 - SNG 600



SNL 500



SNU 500 - SNU 600
SNA 500 - SNA 600



SN 500 - SN 600
SN 200 - SN 300



SD 3100



SD 3000

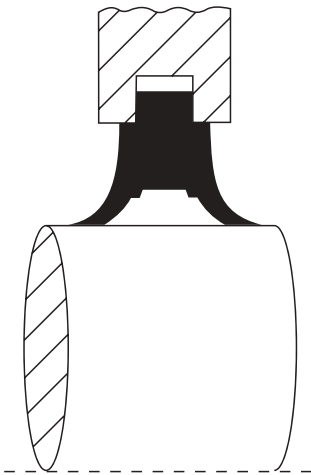

Tenuta in poliuretano "TSNG" per: SNG-SNU
 "TSNG" polyurethan seal for: SNG-SNU

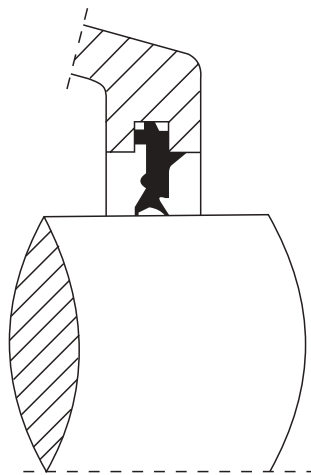

Tenuta in gomma "TSNU" per: SNG-SNU
 "TSNU" rubber seal for: SNG-SNU

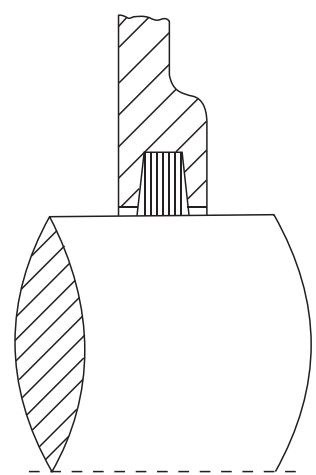

Tenuta in feltro "TSNC" per: SNG-SNU
 "TSNC" felt seal for: SNG-SNU

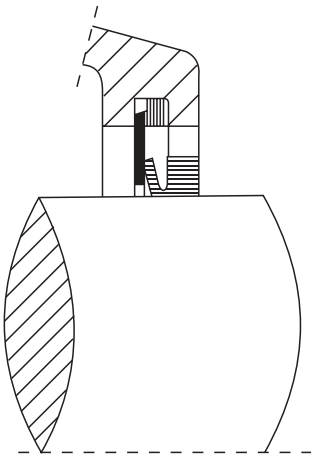

Tenuta v-ring "TSNA" per: SNG-SNU
 "TSNA" v-ring seal for: SNG-SNU

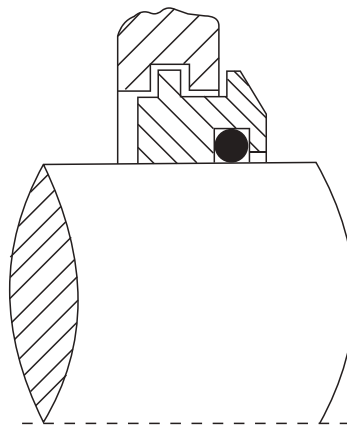

Tenuta a labirinto "TSNS" per: SNG-SNU
 "TSNS" labyrinth seal for: SNG-SNU

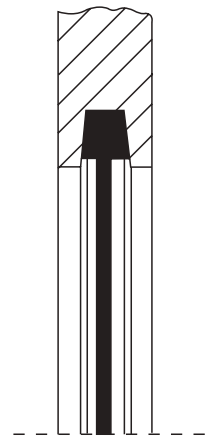

Coperchio di chiusura "A" per: SNG-SNU-SN
 "A" end cover for: SNG-SNU-SN

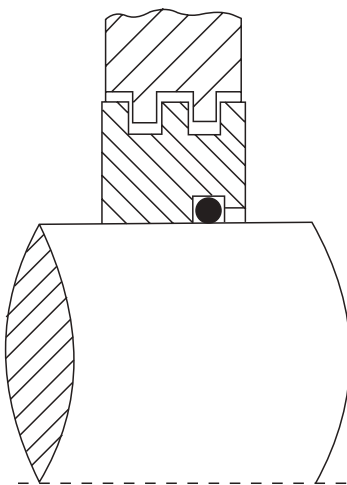

Tenuta a labirinto "TS" per: SN-SD
 "TS" labyrinth seal for: SN-SD

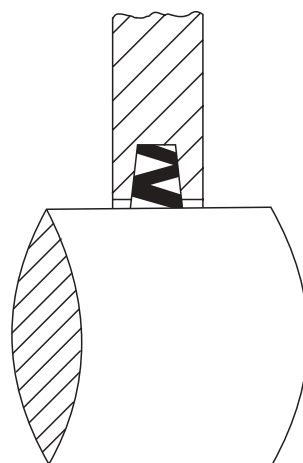

Tenuta in NBR "ZF" per: SN
 "ZF" NBR seals for: SN

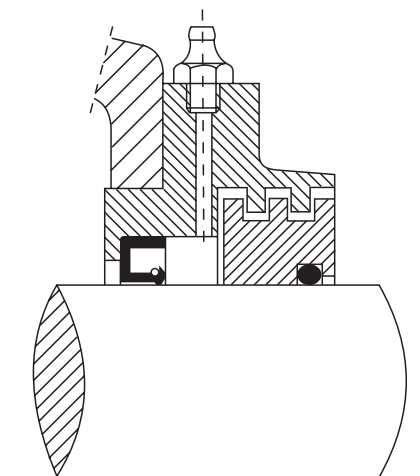

Chiusura di taconite "TAC" per: SN-SD
 "TAC" taconite cover for: SN-SD

A MATERIALI - MATERIALS:
1 SEDE - HOUSING:

Materiale Material	Carico di rottura Tensile strength kgf/mm ²	Carico di snervamento Yield strength kgf/mm ²	Allungamento Elongation	Codice Jis Jis code	Codice USA U.S. code
GHISA CAST IRON	20	-	-	G 5501 (FC 200)	ASTM A 48 GRADO/GRADE 35
ACCIAIO DUTILE DUCTILE IRON (S. G.)	45	30	10%	G 5502 (FCD 450)	ASTM A 536 GRADO/GRADE 65-45-12

2 ACCESSORI - ACCESSORIES:

Dispositivi di chiusura Sealing arrangements	Sigla Ref.	Per For	Materiali Materials
TENUTA IN POLIURETANO POLYURETHAN SEAL	TSNG	SNG-SNU	Poliuretano Polyurethan
TENUTA IN GOMMA U-LOCK RUBBER SEAL	TSNU	SNG-SNU	Gomma Rubber
TENUTA IN FELTRO FELT SEAL	TSNC	SNG-SNU	Feltro Felt
TENUTA V-RING V-RING SEAL	TSNA	SNG-SNU	NBR NBR
TENUTA LABIRINTO LABYRINTH SEAL	TSNS	SNG-SNU	Ghisa Cast iron
COPERCHIO DI CHIUSURA END COVER	A	SNG-SNU-SN	NBR e lamiera in acciaio NBR and Carbon steel platè
TENUTA LABIRINTO LABYRINTH SEAL	TS	SN-SD	Ghisa Cast iron
CHIUSURA DI TACONITE TACONITE COVER TAC	TAC	SD	Ghisa Cast iron

3 TOLLERANZE - TOLERANCES:

	(mm.)	
	Dimensioni - Dimensions	Tolleranze - Tolerances
TOLLERANZA DELLA FUSIONE CASTING TOLERANCE	1-100	± 1,5
	100-200	± 2,0
	200-400	± 3,0
	400-800	± 4,0
	800-1600	± 5,0

TOLLERANZE DI LAVORAZIONE - MACHINE TOLERANCES

1

DIAMETRO DEL FORO (D) - BORE DIAMETER (D)
(μm)

Diametro del foro (mm) Bore diameter (mm)	G7	H7	H8	J7
10-18	+24 +26	-18 -0	+27 -0	+10 -8
18-30	+28 +7	+21 -0	+33 -0	+12 -9
30-50	+34 +9	+25 -0	+39 -0	+14 -11
50-80	+40 +10	+30 -0	+46 -0	+18 -12
80-120	+42 +12	+35 -0	+54 -0	+22 -13
120-180	+54 +14	+40 -0	+63 -0	+26 -14
180-250	+61 +15	+46 -0	+72 -0	+30 -16
250-315	+69 +17	+52 -0	+81 -0	+36 -16
315-400	+75 +18	+57 -0	+89 -0	+39 -18
400-500	+83 +20	+63 -0	+97 -0	+43 -20
500-620	+92 +23	+69 -0	+104 -0	+46 -23

2

ALTRE TOLLERANZE, ECCETTO FORO (D) - OTHER TOLERANCES, EXCEPT BORE (D)
(μm)

Diametro del foro (mm) Bore diameter (mm)	js11	H12	H13	h12	h13
18-30	± 65	+210 -0	+330 -0	+0 -210	+0 -330
30-50	± 80	+250 -0	+390 -0	+0 -250	+0 -390
50-80	± 95	+300 -0	+460 -0	+0 -300	+0 -460
80-120	± 110	+350 -0	+540 -0	+0 -350	+0 -540
120-180	± 125	+400 -0	+630 -0	+0 -400	+0 -630
180-250	± 145	+460 -0	+720 -0	+0 -460	+0 -720
250-315	± 160	+520 -0	+810 -0	+0 -520	+0 -810
315-400	± 180	+570 -0	+890 -0	+0 -570	+0 -890

3

TOLLERANZE SUGGERITE PER SEDE CUSCINETTO - RECOMMENDED FITS OF BEARING HOUSING TOLERANCES

SUPPORTO UNICO O IN DUE PEZZI SPLIT OR SOLID HOUSING	Condizioni di carico Load conditions		Esempio di riferimento Reference example	Tolleranze Tolerances	Anello esterno Outer ring
	Direzione di carico non determinate Direction of load indeterminate	Carico normale e leggero Normal and light load	Motori elettrici, pompe Electric motors, pumps	J7	Possibilità di spostamento Can be displaced
Carico dell'anello interno rotante Rotating inner ring load	Carichi di tutti i tipi Loads of a kinds	Applicazioni generali di cuscinetti e boccole Bearings and bushes general applications	H7	Possibilità di facile spostamento Can easily be displaced	
Carico dell'anello interno rotante Rotating inner ring load	Carico leggero e normale Normal and light load	Supporti Plummer blocks	H8	Possibilità di facile spostamento Can easily be displaced	
Carico dell'anello interno rotante Rotating inner ring load	Incremento della temperatura dell'anello interno attraverso l'albero High temperature rise of inner ring through shaft	Essiccatoi per carta Paper dryers	J7	Possibilità di facile spostamento Can easily be displaced	

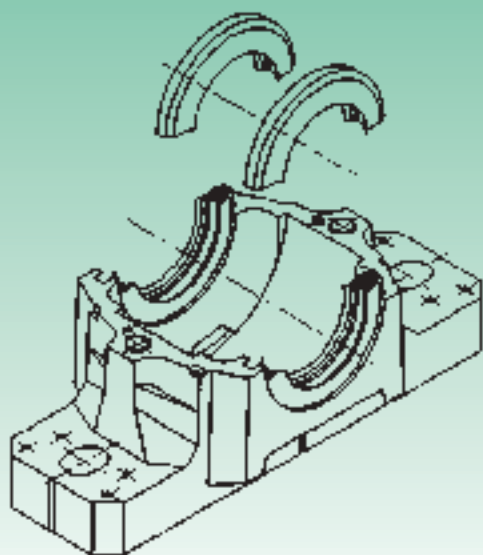

TENUTE "TSNG" SIA PER ALBERI METRICI CHE IN POLLICI
 "TSNG" SEALS FIT BOTH METRIC & INCHES SHAFTS

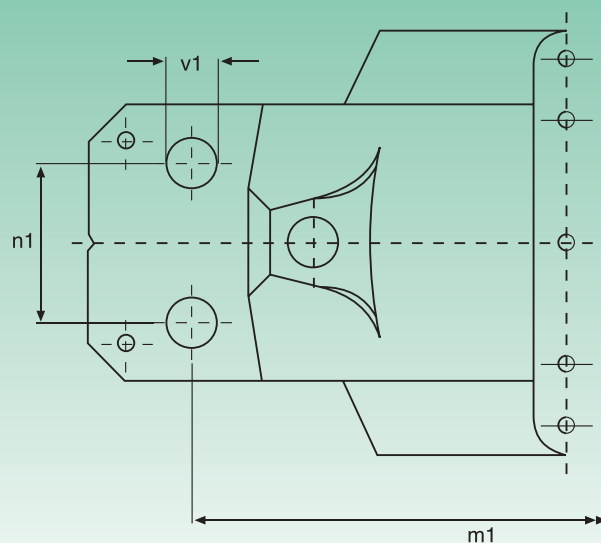

DISPONIBILE PER MONTAGGIO A QUATTRO-FORI
 AVAILABLE FOR FOUR-BOLT MOUNTING

Tipo Type	m1	n1	v1	Bull. fiss. Bolt Size	Tenuta Seal	Diametro albero Shaft diameter			Tenuta Seal	Diametro albero Shaft diameter		
						mm	inch	inch		mm	inch	inch
SNG 507-606D	-	-	-	-	TSNG 507	30	1 1/8	13/16	TSNG 607	30	1 1/8	13/16
SNG 508-607D	160	34	11	M10	TSNG 508	35	15/16	13/8	TSNG 608	35	15/16	13/8
SNG 509D	160	34	11	M10	TSNG 509	40	1 1/2	19/16	TSNG 609	40	1 1/2	19/16
SNG 510-608D	160	34	11	M10	TSNG 510	45	1 11/16	1 3/4	TSNG 610	45	1 11/16	1 3/4
SNG 511-609D	200	40	14	M12	TSNG 511	50	1 15/16	2	TSNG 611	50	1 15/16	2
SNG 512-610D	200	40	14	M12	TSNG 512	55	2 1/8	23/16	TSNG 612	55	2 1/8	23/16
SNG 513-611D	220	48	14	M12	TSNG 513	60	2 3/4	25/16	TSNG 613	60	2 3/4	25/16
SNG 515-612D	220	48	14	M12	TSNG 515	65	2 7/16	2 1/2	TSNG 615	65	2 7/16	2 1/2
SNG 516-613D	252	52	18	M16	TSNG 516	70	2 11/16	2 3/4	TSNG 616	70	2 11/16	2 3/4
SNG 517D	252	52	18	M16	TSNG 517	75	2 15/16	3	TSNG 617	75	2 15/16	3
SNG 518-615D	280	58	18	M16	TSNG 518	80	3 3/16	3 1/4	TSNG 618	80	3 3/16	3 1/4
SNG 519-616D	280	58	18	M16	TSNG 519	85	3 5/16	33/8	TSNG 619	85	3 5/16	33/8
SNG 520-617D	300	66	18	M16	TSNG 520	90	3 7/16	3 1/2	TSNG 620	90	3 7/16	3 1/2
SNG 522-619D	320	74	18	M16	TSNG 522	100	3 15/16	4	-	-	-	-
SNG 524-620D	330	74	18	M16	TSNG 524	110	4 3/16	4 1/4	-	-	-	-
SNG 526D	370	80	22	M20	TSNG 526	115	4 7/16	4 1/2	-	-	-	-
SNG 528D	400	92	26	M24	TSNG 528	125	4 15/16	5	-	-	-	-
SNG 530D	430	100	26	M24	TSNG 530	135	5 3/16	5 1/4	-	-	-	-
SNG 532D	450	100	26	M24	TSNG 532	140	5 7/16	5 1/2	-	-	-	-

INTERCAMBIABILE CON SUPPORTI SNH, SNU, SNA.
INTER-EXCHANGEABLE WITH PLUMMER BLOCKS SNH, SNU, SNA.

Possibilità di scelta per collocazione ingrassatori ed oliatori
Various choice of oil/grease locations

Punzonature per eventuale applicazione di perni di riferimento
Dimples provider for locating pins if required

Molteplici zone per l'installazione di sensori
Various sensor/monitor installing spaces

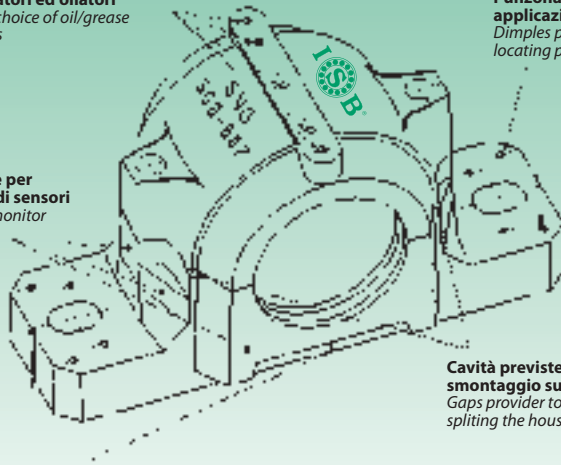

Cavità previste per smontaggio supporto
Gaps provider to help splitting the housings

Base rinforzata per carichi pesanti
Reinforced base for heavy load

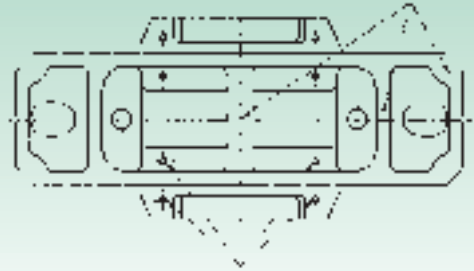

Otto locazioni selezionate per il drenaggio
Eight location selected for drainage

Linee di riferimento centrali per facilitare l'allineamento nel montaggio
Cross center lines for easy alignment in assembly

CARICHI DI ROTTURA - BREAKING LOADS

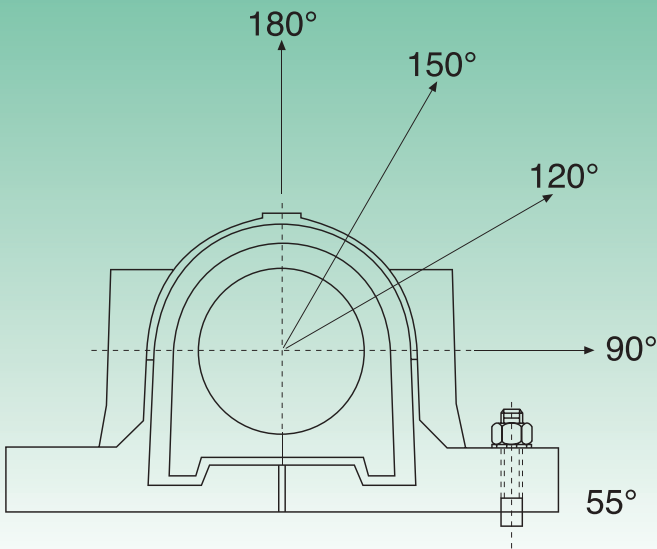

Tipo Type	Carichi di rottura - Breaking loads						
	P ₀	P ₅₅	P ₉₀	P ₁₂₀	P ₁₅₀	P ₁₆₀	P _{assiale} axial
	kN						
SNG 205-505	100	155	95	70	60	80	52
SNG 206-305-506-605	130	170	100	80	65	85	55
SNG 207-507-606	140	190	115	85	80	95	60
SNG 208-307-508-607	150	215	130	95	85	110	70
SNG 209-509	160	230	140	100	90	115	75
SNG 210-510-608	170	265	155	120	110	130	85
SNG 211-511-609	190	275	170	125	115	140	90
SNG 212-512-610	210	300	180	130	120	150	100
SNG 213-513-611	270	340	205	150	130	170	110
SNG 215-515-612	290	410	250	185	160	205	135
SNG 216-516-613	350	430	260	190	175	215	140
SNG 217-517	370	480	290	205	190	240	155
SNG 218-518-615	430	550	340	250	215	275	180
SNG 519-616	-	580	350	260	230	290	190
SNG 520-617	-	620	370	280	250	310	200
SNG 522-619	-	680	410	310	275	340	220
SNG 524-620	-	790	470	350	320	400	260
SNG 526	-	900	540	410	360	450	295
SNG 528	-	1050	630	470	430	530	345
SNG 530	-	1200	730	540	480	600	390
SNG 532	-	1450	860	640	570	720	470

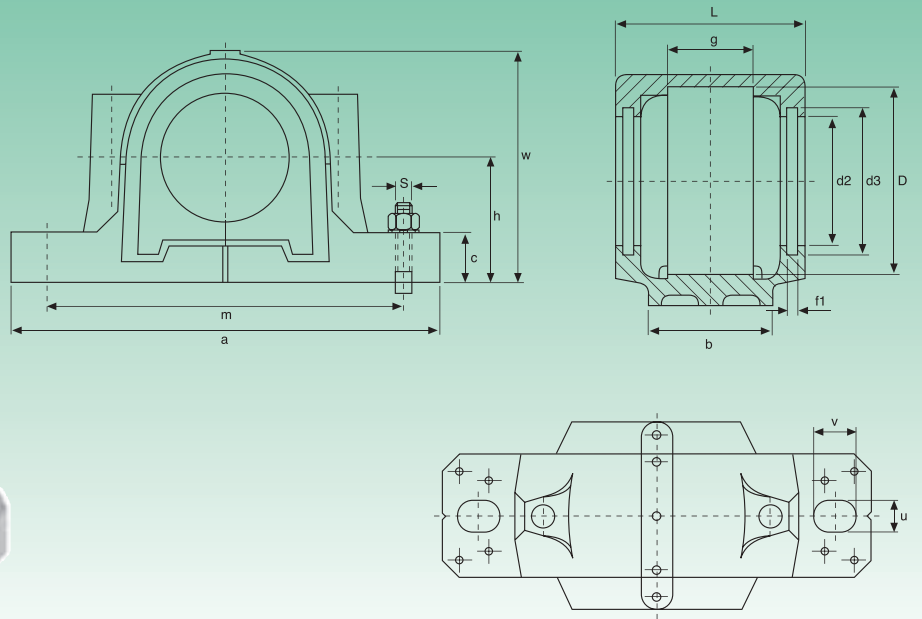

Tipo Type	Diametro albero Shaft diameter		Dimensioni - Dimensions														Bull. fiss. Bolt Size
			D H8	a	b	c	g H12	h	L	w	m	U	V	d2 H12	d3 H12	f1	S
	mm	inch	mm/inch														
SNG 505	20	¾	52	165	46	19	25	40	67	71	130	13	20	31,5	39,5	5	M8x35
SNG 506-605	25	15/16 1	62	185	52	22	32	50	77	87	150	13	22	36,5	44,5	5	M8x40
SNG 507-606	30	11/8 13/16	72	185	52	22	34	50	82	92	150	15	20	46,5	54,5	5	M10x45
SNG 508-607	35	15/16 13/8	80	205	60	25	39	60	85	106	170	15	20	51,5	59,5	5	M10x45
SNG 509	40	1½ 19/16	85	205	60	25	30	60	85	109	170	15	20	56,5	64,5	5	M10x50
SNG 510-608	45	11/16 1¾	90	205	60	25	41	60	90	112	170	15	20	62	70,5	5	M10x50
SNG 511-609	50	115/16 2	100	255	70	28	44	70	95	127	210	18	23	67	75,5	5	M12x60
SNG 512-610	55	21/8 23/16	110	255	70	30	48	70	105	133	210	18	23	72	80,5	5	M12x60
SNG 513-611	60	2¼ 25/16	120	275	80	30	51	80	110	148	230	18	24	77	85,5	5	M12x60
SNG 515-612	65	27/16 2½	130	280	80	30	56	80	115	154	230	18	26	87	95,5	5	M12x70
SNG 516-613	70	211/16 2¾	140	315	90	32	58	95	120	175	260	22	29	92,5	101	5	M16x80
SNG 517	75	215/16 3	150	320	90	32	61	95	125	181	260	22	30	97,5	106	5	M16x80
SNG 518-615	80	33/16 3¼	160	345	100	35	65	100	140	192	290	22	27	102,5	111	5	M16x80
SNG 519-616	85	35/16 33/8	170	345	100	35	68	112	145	209	290	22	27	131	141	6	M16x90
SNG 520-617	90	37/16 3½	180	380	110	40	70	112	160	215	320	26	32	137,5	147,5	6	M20x90
SNG 522-619	100	315/16 4	200	410	120	45	80	125	175	239	350	26	32	147,5	157,5	6	M20x100
SNG 524-620	110	43/16 4¼	215	410	120	45	86	140	185	271	350	26	32	157,5	167,5	6	M20x110
SNG 526	115	47/16 4½	230	445	130	50	90	150	190	290	380	28	35	167,5	177,5	6	M24x120
SNG 528	125	415/16 5	250	500	150	50	98	150	205	302	420	35	42	177,5	187,5	6	M24x130
SNG 530	135	53/16 5¼	270	530	160	60	106	160	220	323	450	35	42	192,5	202,5	6	M24x130
SNG 532	140	57/16 5½	290	550	160	60	114	170	235	344	470	35	42	202,5	212,5	6	M24x130

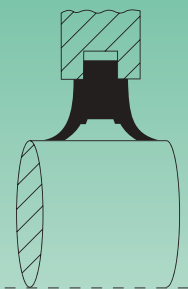

Tenuta in poliuretano "TSNG" per: SNG-SNU
"TSNG" polyurethan seal for: SNG-SNU

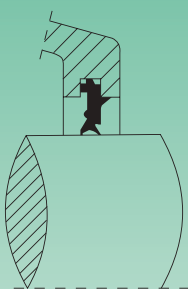

Tenuta in gomma "TSNU" per: SNG-SNU
"TSNU" rubber seal for: SNG-SNU

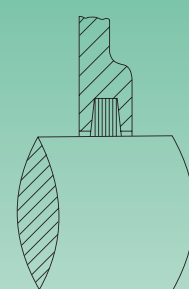

Tenuta in feltro "TSNC" per: SNG-SNU
"TSNC" felt seal for: SNG-SNU

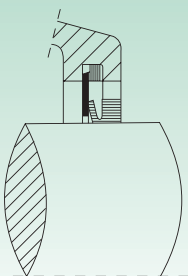

Tenuta v-ring "TSNA" per: SNG-SNU
"TSNA" v-ring seal for: SNG-SNU

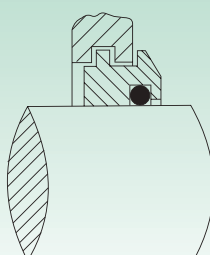

Tenuta a labirinto "TSNS" per: SNG-SNU
"TSNS" labyrinth seal for: SNG-SNU

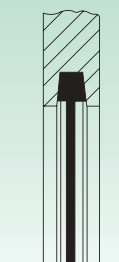

Coperchio di chiusura "A" per: SNG-SNU-SN
"A" end cover for: SNG-SNU-SN

Cuscinetto orientabile a sfere (foro conico) Self-aligning ball bearing (conical bore)	Cuscinetto orientabile a rulli (foro conico) Self-aligning roller bearing (conical bore)	Bussola (metrica) Adapter sleeve (metric)	Anello di centraggio Locating ring		Peso Weight kg	"TSNG" Tenuta in poliuretano Polyurethan seal	"TSNU" Tenuta in gomma Rubber seal	"TSNC" Tenuta in feltro Felt seal	"TSNA" Tenuta V-Ring V-Ring seal	"TSNS" Tenuta a labirinto Labyrinth seal	"A" Coperchio di chiusura End cover	Tipo Type
			Tipo Type	Q.tà Q.ty								
1205 K	-	H 205	SR 52x5	2	2,1	TSNG 505	TSNU 505	TSNC 505	TSNA 505	TSNS 505	A 505	SNG 505
2205 K	22205 K	H 305	SR 52x3,5	2								
1206 K	-	H 206	SR 62x8	2	2,4	TSNG 506	TSNU 506	TSNC 506	TSNA 506	TSNS 506	A 506-605	SNG 506-605
2206 K	22206 K	H 306	SR 62x6	2								
1207 K	-	H 207	SR 72x8,5	2	2,2	TSNG 507	TSNU 507	TSNC 507	TSNA 507	TSNS 507	A 507-606	SNG 507-606
2207 K	22207 K	H 307	SR 72x5,5	2								
1208 K	-	H 208	SR 80x10,5	2	2,8	TSNG 508	TSNU 508	TSNC 508	TSNA 508	TSNS 508	A 508-607	SNG 508-607
2208 K	22208 K	H 308	SR 80x8	2								
1209 K	-	H 209	SR 85x5,5	2	3,0	TSNG 509	TSNU 509	TSNC 509	TSNA 509	TSNS 509	A 509	SNG 509
2209 K	22209 K	H 309	SR 85x7	1								
		H 309	SR 85x3,5	2								
1210 K	-	H 210	SR 90x10,5	2	3,1	TSNG 510	TSNU 510	TSNC 510	TSNA 510	TSNS 510	A 510-608	SNG 510-608
2210 K	22210 K	H 310	SR 90x9	2								
1211 K	-	H 211	SR 100x11,5	2	4,5	TSNG 511	TSNU 511	TSNC 511	TSNA 511	TSNS 511	A 511-609	SNG 511-609
2211 K	22211 K	H 311	SR 100x9,5	2								
1212 K	-	H 212	SR 110x13	2	5,0	TSNG 512	TSNU 512	TSNC 512	TSNA 512	TSNS 512	A 512-610	SNG 512-610
2212 K	22212 K	H 312	SR 110x10	2								
1213 K	-	H 213	SR 120x14	2	6,1	TSNG 513	TSNU 513	TSNC 513	TSNA 513	TSNS 513	A 513-611	SNG 513-611
2213 K	22213 K	H 313	SR 120x10	2								
1215 K	-	H 215	SR 130x15,5	2	6,5	TSNG 515	TSNU 515	TSNC 515	TSNA 515	TSNS 515	A 515-612	SNG 515-612
2215 K	22215 K	H 315	SR 130x12,5	2								
1216 K	-	H 216	SR 140x16	2	9,0	TSNG 516	TSNU 516	TSNC 516	TSNA 516	TSNS 516	A 516-613	SNG 516-613
2216 K	22216 K	H 316	SR 140x12,5	2								
1217 K	-	H 217	SR 150x16,5	2	10,2	TSNG 517	TSNU 517	TSNC 517	TSNA 517	TSNS 517	A 517	SNG 517
2217 K	22217 K	H 317	SR 150x12,5	2								
1218 K	-	H 218	SR 160x17,5	2	12,4	TSNG 518	TSNU 518	TSNC 518	TSNA 518	TSNS 518	A 518-615	SNG 518-615
2218 K	22218 K	H 318	SR 160x12,5	2								
2218 K	23218 K	H 2318	SR 160x12,5	1								
1219 K	-	H 219	SR 170x18	2	13,5	TSNG 519	TSNU 519	TSNC 519	TSNA 519	TSNS 519	A 519-616	SNG 519-616
2219 K	22219 K	H 319	SR 170x12,5	2								
1220 K	22220 K	H 320	SR 180x12	2	17,5	TSNG 520	TSNU 520	TSNC 520	TSNA 520	TSNS 520	A 520-617	SNG 520-617
2220 K	23220 K	H 2320	SR 180x9,7	1								
1222 K	22222 K	H 322	SR 200x13,5	2	20,5	TSNG 522	TSNU 522	TSNC 522	TSNA 522	TSNS 522	A 522-619	SNG 522-619
2222 K	23222 K	H 2322	SR 200x10	1								
1224 K	22224 K	H 3124	SR 215x14	2	25,5	TSNG 524	TSNU 524	TSNC 524	TSNA 524	TSNS 524	A 524-620	SNG 524-620
-	23224 K	H 2324	SR 215x10	1								
-	22226 K	H 3126	SR 230x13	2	33,0	TSNG 526	TSNU 526	TSNC 526	TSNA 526	TSNS 526	A 526	SNG 526
-	23226 K	H 2326	SR 230x10	1								
-	22228 K	H 3128	SR 250x15	2	42,0	TSNG 528	TSNU 528	TSNC 528	TSNA 528	TSNS 528	A 528	SNG 528
-	23228 K	H 2328	SR 250x10	1								
-	22230 K	H 3130	SR 270x16,5	2	53,0	TSNG 530	TSNU 530	TSNC 530	TSNA 530	TSNS 530	A 530	SNG 530
-	23230 K	H 2330	SR 270x10	1								
-	22232 K	H 3132	SR 290x17	2	55,0	TSNG 532	TSNU 532	TSNC 532	TSNA 532	TSNS 532	A 532	SNG 532
-	23232 K	H 2332	SR 290x10	1								

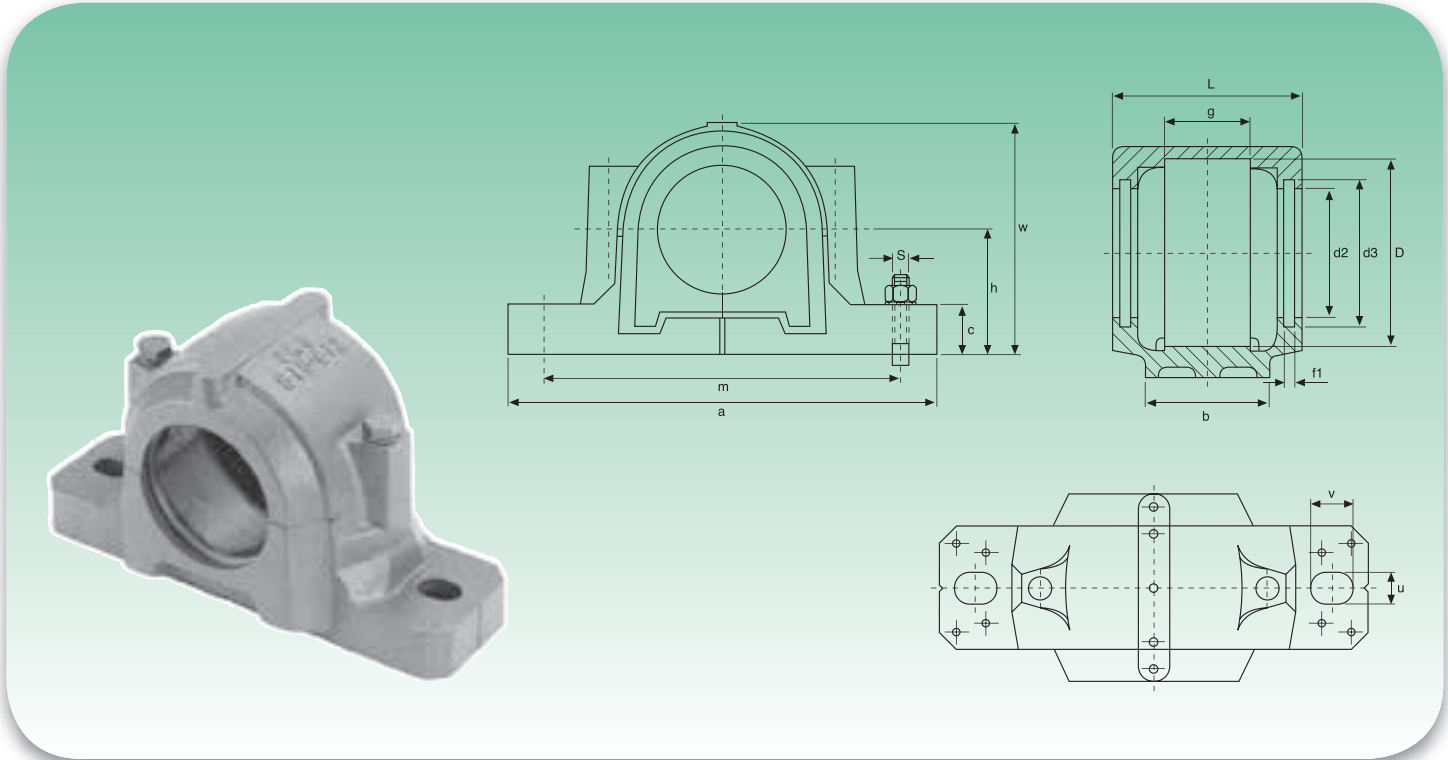

Tipo Type	Diametro albero Shaft diameter			Dimensioni - Dimensions													Bull. fiss. Bolt Size	
				D H8	a	b	c	g H12	h	L	w	m	U	V	d2 H12	d3 H12	f1	S
	mm	inch		mm/inch														
SNG 508-607	30	1 1/8	13/16	80	205	60	25	39	60	85	106	170	15	20	51,5	59,5	5	M10x45
SNG 510-608	35	1 5/16	13/8	90	205	60	25	41	60	90	112	170	15	20	62	70,5	5	M10x50
SNG 511-609	40	1 1/2	19/16	100	255	70	28	44	70	95	127	210	18	23	67	75,5	5	M12x60
SNG 512-610	45	1 11/16	1 3/4	110	255	70	30	48	70	105	133	210	18	23	72	80,5	5	M12x60
SNG 513-611	50	1 15/16	2	120	275	80	30	51	80	110	148	230	18	24	77	85,5	5	M12x60
SNG 515-612	55	2 1/8	23/16	130	280	80	30	56	80	115	154	230	18	26	87	95,5	5	M12x70
SNG 516-613	60	2 1/4	25/16	140	315	90	32	58	95	120	175	260	22	29	92,5	101	5	M16x80
SNG 518-615	65	2 7/16	2 1/2	160	345	100	35	65	100	140	192	290	22	27	102,5	111	5	M16x80
SNG 519-616	70	2 11/16	2 3/4	170	345	100	35	68	112	145	209	290	22	27	131	141	6	M16x90
SNG 520-617	75	2 15/16	3	180	380	110	40	70	112	160	215	320	26	32	137,5	147,5	6	M20x90
SNG 522-619	85	3 5/16	3 3/8	200	410	120	45	80	125	175	239	350	26	32	147,5	157,5	6	M20x100
SNG 524-620	90	3 7/16	3 1/2	215	410	120	45	86	140	185	271	350	26	32	157,5	167,5	6	M20x110

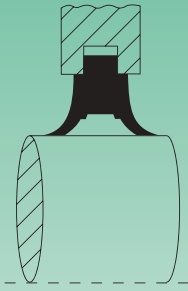

Tenuta in poliuretano "TSNG" per: SNG-SNU
"TSNG" polyurethan seal for: SNG-SNU

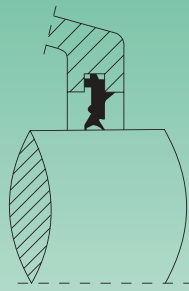

Tenuta in gomma "TSNU" per: SNG-SNU
"TSNU" rubber seal for: SNG-SNU

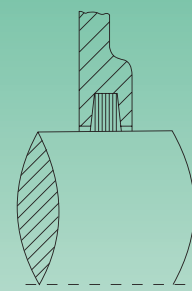

Tenuta in feltro "TSNC" per: SNG-SNU
"TSNC" felt seal for: SNG-SNU

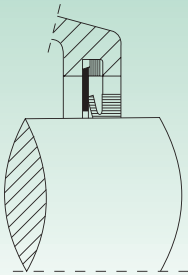

Tenuta v-ring "TSNA" per: SNG-SNU
"TSNA" v-ring seal for: SNG-SNU

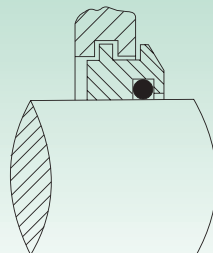

Tenuta a labirinto "TSNS" per: SNG-SNU
"TSNS" labyrinth seal for: SNG-SNU

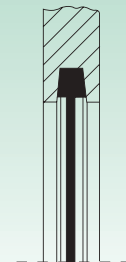

Coperchio di chiusura "A" per: SNG-SNU-SN
"A" end cover for: SNG-SNU-SN

Cuscinetto orientabile a sfere (foro conico) Self-aligning ball bearing (conical bore)	Cuscinetto orientabile a rulli (foro conico) Self-aligning roller bearing (conical bore)	Bussola (metrica) Adapter sleeve (metric)	Anello di centraggio Locating ring		Peso Weight kg	"TSNG" Tenuta in poliuretano Polyurethan seal	"TSNU" Tenuta in gomma Rubber seal	"TSNC" Tenuta in feltro Felt seal	"TSNA" Tenuta V-Ring V-Ring seal	"TSNS" Tenuta a labirinto Labyrinth seal	"A" Coperchio di chiusura End cover	Tipo Type
			Tipo Type	Q.tà Q.ty								
1307 K	-	H 307	SR 80x9	2	2,8	TSNG 607	TSNU 607	TSNC 607	TSNA 607	TSNS 607	A 508-607	SNG 508-607
2307 K	-	H 2307	SR 80x8	1								
1308 K	21308 K	H 308	SR 90x9	2	3,1	TSNG 608	TSNU 608	TSNC 608	TSNA 608	TSNS 608	A 510-608	SNG 510-608
2308 K	22308 K	H 2308	SR 90x8	1								
1309 K	21309 K	H 309	SR 100x9,5	2	4,5	TSNG 609	TSNU 609	TSNC 609	TSNA 609	TSNS 609	A 511-609	SNG 511-609
2309 K	22309 K	H 2309	SR 100x8	1								
1310 K	21310 K	H 310	SR 110x10,5	2	5,0	TSNG 610	TSNU 610	TSNC 610	TSNA 610	TSNS 610	A 512-610	SNG 512-610
2310 K	22310 K	H 2310	SR 110x8	1								
1311 K	21311 K	H 311	SR 120x11	2	6,1	TSNG 611	TSNU 611	TSNC 611	TSNA 611	TSNS 611	A 513-611	SNG 513-611
2311 K	22311 K	H 2311	SR 120x8	1								
1312 K	21312 K	H 312	SR 130x12,5	2	6,5	TSNG 612	TSNU 612	TSNC 612	TSNA 612	TSNS 612	A 515-612	SNG 515-612
2312 K	22312 K	H 2312	SR 130x10	1								
1313 K	21313 K	H 313	SR 140x12,5	2	9,0	TSNG 613	TSNU 613	TSNC 613	TSNA 613	TSNS 613	A 516-613	SNG 516-613
2313 K	22313 K	H 2313	SR 140x10	1								
1315 K	21315 K	H 315	SR 160x14	2	12,4	TSNG 615	TSNU 615	TSNC 615	TSNA 615	TSNS 615	A 518-615	SNG 518-615
2315 K	22315 K	H 2315	SR 160x10	1								
1316 K	21316 K	H 316	SR 170x14,5	2	13,5	TSNG 616	TSNU 616	TSNC 616	TSNA 616	TSNS 616	A 519-616	SNG 519-616
2316 K	22316 K	H 2316	SR 170x10	1								
1317 K	21317 K	H 317	SR 180x14,5	2	17,5	TSNG 617	TSNU 617	TSNC 617	TSNA 617	TSNS 617	A 520-617	SNG 520-617
2317 K	22317 K	H 2317	SR 180x10	1								
1319 K	-	H 319	SR 200x17,5	2	20,5	TSNG 619	TSNU 619	TSNC 619	TSNA 619	TSNS 619	A 522-619	SNG 522-619
2319 K	22319 K	H 2319	SR 200x13	1								
-	-	H -	-	-	25,5	TSNG 620	TSNU 620	TSNC 620	TSNA 620	TSNS 620	A 524-620	SNG 524-620
2320 K	22320 K	H 2320	SR 215x13	1								

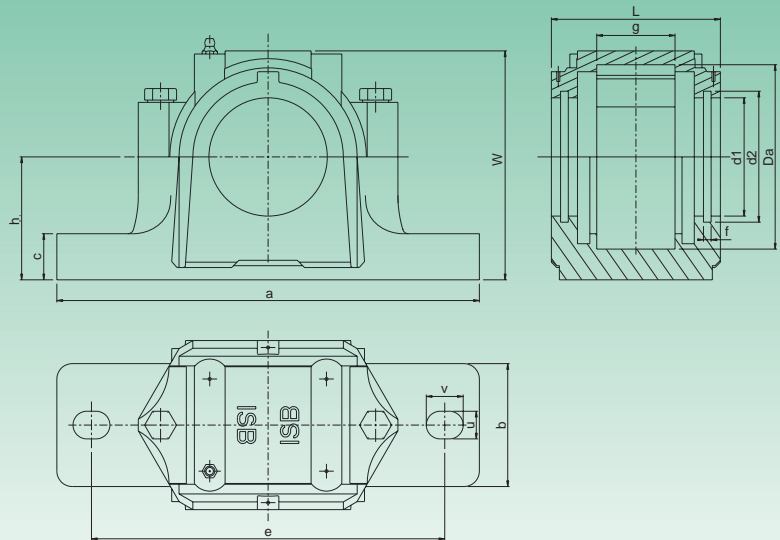

Tipo Type	Diametro albero Shaft diameter	Dimensioni - Dimensions														Bull. fiss. Bolt Size
		Da H8	a	b	c	g H12	h H12	L	w	e	v	u	d1 H12	d2 H12	f1	S
mm		mm														
SNL505	20	52	165	46	19	25	40	67	74	130	20	15	31,5	39,5	5	M8x35
SNL506	25	62	185	52	22	32	50	77	89	150	20	15	36,5	44,5	5	M8x40
SNL507-606	30	72	185	52	22	34	50	82	93	150	20	15	46,5	54,5	5	M10x50
SNL508-607	35	80	205	60	25	39	60	85	108	170	20	15	51,5	59,5	5	M10x50
SNL509	40	85	205	60	25	30	60	85	109	170	20	15	56,5	64,5	5	M10x50
SNL510-608	45	90	205	60	25	41	60	90	113	170	20	15	62	70,5	5	M10x50
SNL511-609	50	100	255	70	28	44	70	95	128	210	24	18	67	75,5	5	M12x60
SNL512-610	55	110	255	70	30	48	70	105	134	210	24	18	72	80,5	5	M12x60
SNL513-611	60	120	275	80	30	51	80	110	149	230	24	18	77	85,5	5	M12x60
SNL515-612	65	130	280	80	30	56	80	115	155	230	24	18	87	95,5	5	M12x70
SNL516-613	70	140	315	90	32	58	95	120	177	260	28	22	92,5	101	5	M16x80
SNL517	75	150	320	90	32	61	95	125	183	260	28	22	97,5	106	5	M16x80
SNL518-615	80	160	345	100	35	65	100	140	194	290	28	22	102,5	111	5	M16x80
SNL519-616	85	170	345	100	35	68	112	145	212	290	28	22	131	141	6	M16x90
SNL520-617	90	180	380	110	40	70	112	160	218	320	32	26	137,5	147,5	6	M20x90
SNL522-619	100	200	410	120	45	80	125	175	242	350	32	26	147,5	157,5	6	M20x100
SNL524-620	110	215	410	120	45	86	140	185	271	350	32	26	157,5	167,5	6	M20x110
SNL526	115	230	445	130	50	90	150	190	290	380	35	28	167,5	177,5	6	M20x110
SNL528	125	250	500	150	50	98	150	205	302	420	42	35	177,5	187,5	6	M24x130
SNL530	135	270	530	160	60	106	160	220	323	450	42	35	192,5	202,5	6	M24x130
SNL532	140	290	550	160	60	114	170	235	344	470	42	35	202,5	212,5	6	M24x130

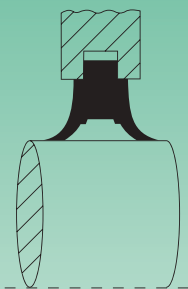

Tenuta in poliuretano "TSNG" per: SNG-SNU
"TSNG" polyurethan seal for: SNG-SNU

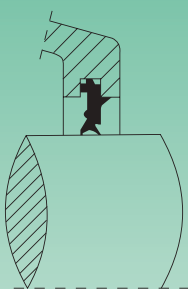

Tenuta in gomma "TSNU" per: SNG-SNU
"TSNU" rubber seal for: SNG-SNU

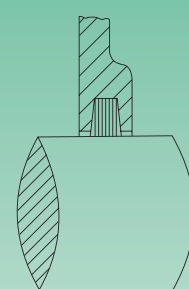

Tenuta in feltro "TSNC" per: SNG-SNU
"TSNC" felt seal for: SNG-SNU

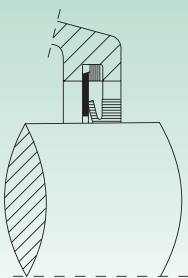

Tenuta v-ring "TSNA" per: SNG-SNU
"TSNA" v-ring seal for: SNG-SNU

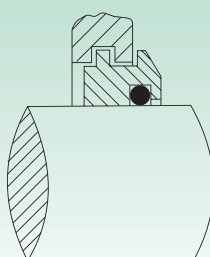

Tenuta a labirinto "TSNS" per: SNG-SNU
"TSNS" labyrinth seal for: SNG-SNU

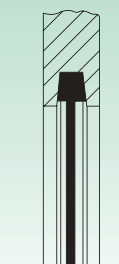

Coperchio di chiusura "A" per: SNG-SNU-SN
"A" end cover for: SNG-SNU-SN

Cuscinetto orientabile a sfere (foro conico) Self-aligning ball bearing (conical bore)	Cuscinetto orientabile a rulli (foro conico) Self-aligning roller bearing (conical bore)	Bussola (metrica) Adapter sleeve (metric)	Anello di centraggio Locating ring		Peso Weight kg	"TSNG" Tenuta in poliuretano Polyurethan seal	"TSNU" Tenuta in gomma Rubber seal	"TSNC" Tenuta in feltro Felt seal	"TSNA" Tenuta V-Ring V-Ring seal	"TSNS" Tenuta a labirinto Labyrinth seal	"A" Coperchio di chiusura End cover	Tipo Type
			Tipo Type	Q.tà Q.ty								
1205 K	-	H 205	SR 52x5	2	1,45	TSNG 505	TSNU 505	TSNC 505	TSNA 505	TSNS 505	A 505	SNL505
2205 K	22205 K	H 305	SR 52x3,5	2								
1206 K	-	H 206	SR 62x8	2	2,0	TSNG 506	TSNU 506	TSNC 506	TSNA 506	TSNS 506	A 506-605	SNL506
2206 K	22206 K	H 306	SR 62x6	2								
1207 K	-	H 207	SR 72x8,5	2	2,2	TSNG 507	TSNU 507	TSNC 507	TSNA 507	TSNS 507	A 507-606	SNL507-606
2207 K	22207 K	H 307	SR 72x5,5	2								
1208 K	-	H 208	SR 80x10,5	2	2,9	TSNG 508	TSNU 508	TSNC 508	TSNA 508	TSNS 508	A 508-607	SNL508-607
2208 K	22208 K	H 308	SR 80x8	2								
1209 K	-	H 209	SR 85x5,5	2	2,9	TSNG 509	TSNU 509	TSNC 509	TSNA 509	TSNS 509	A 509	SNL509
2209 K	22209 K	H 309	SR 85x7	1								
		H 309	SR 85x3,5	2								
1210 K	-	H 210	SR 90x10,5	2	3,2	TSNG 510	TSNU 510	TSNC 510	TSNA 510	TSNS 510	A 510-608	SNL510-608
2210 K	22210 K	H 310	SR 90x9	2								
1211 K	-	H 211	SR 100x11,5	2	4,4	TSNG 511	TSNU 511	TSNC 511	TSNA 511	TSNS 511	A 511-609	SNL511-609
2211 K	22211 K	H 311	SR 100x9,5	2								
1212 K	-	H 212	SR 110x13	2	5,1	TSNG 512	TSNU 512	TSNC 512	TSNA 512	TSNS 512	A 512-610	SNL512-610
2212 K	22212 K	H 312	SR 110x10	2								
1213 K	-	H 213	SR 120x14	2	6,5	TSNG 513	TSNU 513	TSNC 513	TSNA 513	TSNS 513	A 513-611	SNL513-611
2213 K	22213 K	H 313	SR 120x10	2								
1215 K	-	H 215	SR 130x15,5	2	7,0	TSNG 515	TSNU 515	TSNC 515	TSNA 515	TSNS 515	A 515-612	SNL515-612
2215 K	22215 K	H 315	SR 130x12,5	2								
1216 K	-	H 216	SR 140x16	2	9,5	TSNG 516	TSNU 516	TSNC 516	TSNA 516	TSNS 516	A 516-613	SNL516-613
2216 K	22216 K	H 316	SR 140x12,5	2								
1217 K	-	H 217	SR 150x16,5	2	10,0	TSNG 517	TSNU 517	TSNC 517	TSNA 517	TSNS 517	A 517	SNL517
2217 K	22217 K	H 317	SR 150x12,5	2								
1218 K	-	H 218	SR 160x17,5	2	12,5	TSNG 518	TSNU 518	TSNC 518	TSNA 518	TSNS 518	A 518-615	SNL518-615
2218 K	22218 K	H 318	SR 160x12,5	2								
2218 K	23218 K	H 2318	SR 160x12,5	1								
1219 K	-	H 219	SR 170x18	2	13,7	TSNG 519	TSNU 519	TSNC 519	TSNA 519	TSNS 519	A 519-616	SNL519-616
2219 K	22219 K	H 319	SR 170x12,5	2								
1220 K	22220 K	H 320	SR 180x12	2	17,6	TSNG 520	TSNU 520	TSNC 520	TSNA 520	TSNS 520	A 520-617	SNL520-617
2220 K	23220 K	H 2320	SR 180x9,7	1								
1222 K	22222 K	H 322	SR 200x13,5	2	22,0	TSNG 522	TSNU 522	TSNC 522	TSNA 522	TSNS 522	A 522-619	SNL522-619
2222 K	23222 K	H 2322	SR 200x10	1								
1224 K	22224 K	H 3124	SR 215x14	2	26,2	TSNG 524	TSNU 524	TSNC 524	TSNA 524	TSNS 524	A 524-620	SNL524-620
-	23224 K	H 2324	SR 215x10	1								
-	22226 K	H 3126	SR 230x13	2	33,0	TSNG 526	TSNU 526	TSNC 526	TSNA 526	TSNS 526	A 526	SNL526
-	23226 K	H 2326	SR 230x10	1								
-	22228 K	H 3128	SR 250x15	2	40,0	TSNG 528	TSNU 528	TSNC 528	TSNA 528	TSNS 528	A 528	SNL528
-	23228 K	H 2328	SR 250x10	1								
-	22230 K	H 3130	SR 270x16,5	2	49,0	TSNG 530	TSNU 530	TSNC 530	TSNA 530	TSNS 530	A 530	SNL530
-	23230 K	H 2330	SR 270x10	1								
-	22232 K	H 3132	SR 290x17	2	55,0	TSNG 532	TSNU 532	TSNC 532	TSNA 532	TSNS 532	A 532	SNL532
-	23232 K	H 2332	SR 290x10	1								

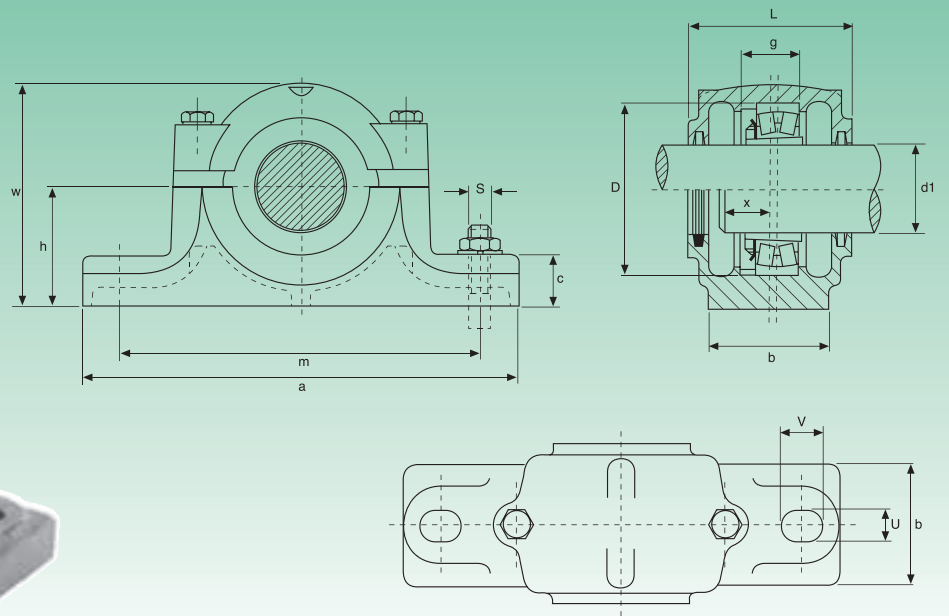

Tipo Type	Diametro albero Shaft diameter		Dimensioni - Dimensions										Bull. fiss. Bolt Size	
	d1		D H8	a	b	c	g H12	h h12	L ± 5	w	m	U	V	S
	mm	inch	mm/inch											
SN 506	25	1	62	185	52	22	30	50	77	90	150	15	20	M12
SN 507	30	1 1/8	72	185	52	22	33	50	82	95	150	15	20	M12
SN 508	35	1 1/4	80	205	60	25	33	60	85	110	170	15	20	M12
SN 509	40	1 1/2	85	205	60	25	31	60	85	112	170	15	20	M12
SN 510	45	1 3/4	90	205	60	25	33	60	90	115	170	15	20	M12
SN 511	50	2	100	255	70	28	33	70	95	130	210	18	23	M16
SN 512	55	2 1/8	110	255	70	30	38	70	105	135	210	18	23	M16
SN 513	60	2 1/4	120	275	80	30	43	80	110	150	230	18	23	M16
SN 515	65	2 1/2	130	280	80	30	41	80	115	155	230	18	23	M16
SN 516	70	2 3/4	140	315	90	32	43	95	120	175	260	22	27	M20
SN 517	75	3	150	320	90	32	46	95	125	185	260	22	27	M20
SN 518	80	3 1/4	160	345	100	35	62,4	100	145	195	290	22	27	M20
SN 519	85	-	170	345	100	35	53	112	140	210	290	22	27	M20
SN 520	90	3 1/2	180	380	110	40	70,3	112	160	218	320	26	32	M24
SN 522	100	4	200	410	120	45	80	125	175	240	350	26	32	M24
SN 524	110	4 1/4	215	410	120	45	86	140	185	270	350	26	32	M24
SN 526	115	4 1/2	230	445	130	50	90	150	190	290	380	28	36	M24
SN 528	125	5	250	500	150	50	98	150	205	305	420	33	42	M30
SN 530	135	5 1/4	270	530	160	60	106	160	220	325	450	33	42	M30
SN 532	140	5 1/2	290	550	160	60	114	170	235	345	470	33	42	M30

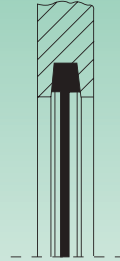
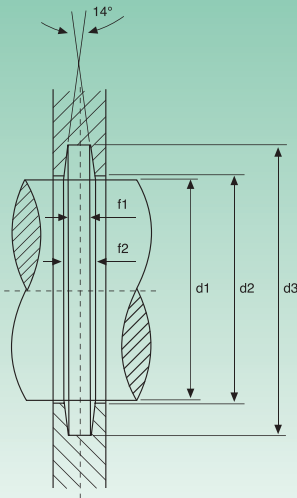

Coperchio di chiusura "A" per: SNG-SNU-SN
"A" end cover for: SNG-SNU-SN

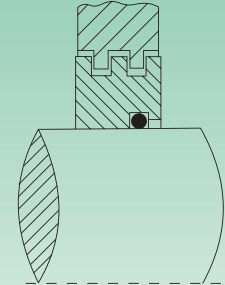

Tenuta a labirinto "TS" per: SN-SD
"TS" labyrinth seal for: SN-SD

Se non diversamente specificato viene fornito il supporto aperto di tipo "B"
Unless specified "B" type open housing supplied

X	Dimensioni - Dimensions				Peso Weight	Cuscinetto orientabile a sfere (foro conico) Self-aligning ball bearing (conical bore)	Cuscinetto orientabile a rulli (foro conico) Self-aligning roller bearing (conical bore)	Bussola Adapter sleeve		Anello di centraggio Locating ring		"A" Coperchio di chiusura End cover	"TS" Tenuta a labirinto Labyrinth seal	Tipo Type
	d2 H12	d3 H12	f1 H13	f2				mm	inch	Tipo Type	Q.tà Q.ty			
22	26,5	38	4	5,4	1,6	1206 K	-	H 206	HE 206	SR 62x7	2	A 506	TS 506	SN 506
						2206 K	22206 K	H 306	HE 306	SR 62x10	1			
24	31,5	43	4	5,4	2,1	1207 K	-	H 207	HE 207	SR 72x8	2	A 507	TS 507	SN 507
						2207 K	22207 K	H 307	HE 307	SR 72x10	1			
26	36,5	48	4	5,4	2,7	1208 K	-	H 208	HE 208	SR 80x7,5	2	A 508	TS 508	SN 508
						2208 K	22208 K	H 308	HE 308	SR 80x10	1			
28	41,5	53	4	5,4	2,8	1209 K	-	H 209	HE 209	SR 85x6	2	A 509	TS 509	SN 509
						2209 K	22209 K	H 309	HE 309	SR 85x8	1			
28	46,5	58	4	5,4	3,0	1210 K	-	H 210	HE 210	SR 90x6,5	2	A 510	TS 510	SN 510
						2210 K	22210 K	H 310	HE 310	SR 90x10	1			
30	51,5	67	5	6,9	4,0	1211 K	-	H 211	HE 211	SR 100x6	2	A 511	TS 511	SN 511
						2211 K	22211 K	H 311	HE 311	SR 100x8	1			
32	56,5	72	5	6,9	4,5	1212 K	-	H 212	HE 212	SR 110x8	2	A 512	TS 512	SN 512
						2212 K	22212 K	H 312	HE 312	SR 110x10	1			
36	62	77	5	6,8	5,5	1213 K	-	H 213	HE 213	SR 120x10	2	A 513	TS 513	SN 513
						2213 K	22213 K	H 313	HE 313	SR 120x12	1			
38	67	82	5	6,8	6,0	1215 K	-	H 215	HE 215	SR 130x8	2	A 515	TS 515	SN 515
						2215 K	22215 K	H 315	HE 315	SR 130x10	1			
40	72	89	6	8,1	8,2	1216 K	-	H 216	HE 216	SR 140x8,5	2	A 516	TS 516	SN 516
						2216 K	22216 K	H 316	HE 316	SR 140x10	1			
42	77	94	6	8,1	9,0	1217 K	-	H 217	HE 217	SR 150x9	2	A 517	TS 517	SN 517
						2217 K	22217 K	H 317	HE 317	SR 150x10	1			
50	82	99	6	8,1	11,6	1218 K	22218 K	H 218	HE 218	SR 160x16,2	2	A 518	TS 518	SN 518
						2218 K	23218 K	H 318	HE 318	SR 160x11,2	2			
52	87	104	6	8,1	11,8	1219 K	-	H 219	HE 219	SR 160x10	1	A 519	TS 519	SN 519
						2219 K	22219 K	H 319	HE 319	SR 170x10,5	2			
54	92	111	7	9,3	15,5	2220 K	22220 K	H 320	HE 320	SR 170x10	1	A 520	TS 520	SN 520
						-	23220 K	H 2320	HE 2320	SR 180x12,1	2			
60	102	125	8	10,8	19	2222 K	22222 K	H 322	HE 322	SR 180x10	1	A 522	TS 522	SN 522
						-	23222 K	H 2322	HE 2322	SR 200x13,5	2			
64	113	135	8	10,7	23	-	22224 K	H 3124	HE 3124	SR 200x10	1	A 524	TS 524	SN 524
						-	23224 K	H 2324	HE 2324	SR 215x14	2			
64	118	140	8	10,7	28	-	22226 K	H 3126	HE 3126	SR 215x10	1	A 526	TS 526	SN 526
						-	23226 K	H 2326	HE 2326	SR 230x13	2			
70	128	154	9	12,2	37	-	22228 K	H 3128	HE 3128	SR 230x10	1	A 528	TS 528	SN 528
						-	23228 K	H 2328	HE 2328	SR 250x15	2			
76	138	164	9	12,2	44	-	22230 K	H 3130	HE 3130	SR 250x10	1	A 530	TS 530	SN 530
						-	23230 K	H 2330	HE 2330	SR 270x16,5	2			
80	143	173	10	13,7	50	-	22232 K	H 3132	HE 3132	SR 270x10	1	A 532	TS 532	SN 532
						-	23232 K	H 2332	HE 2332	SR 290x17	2			

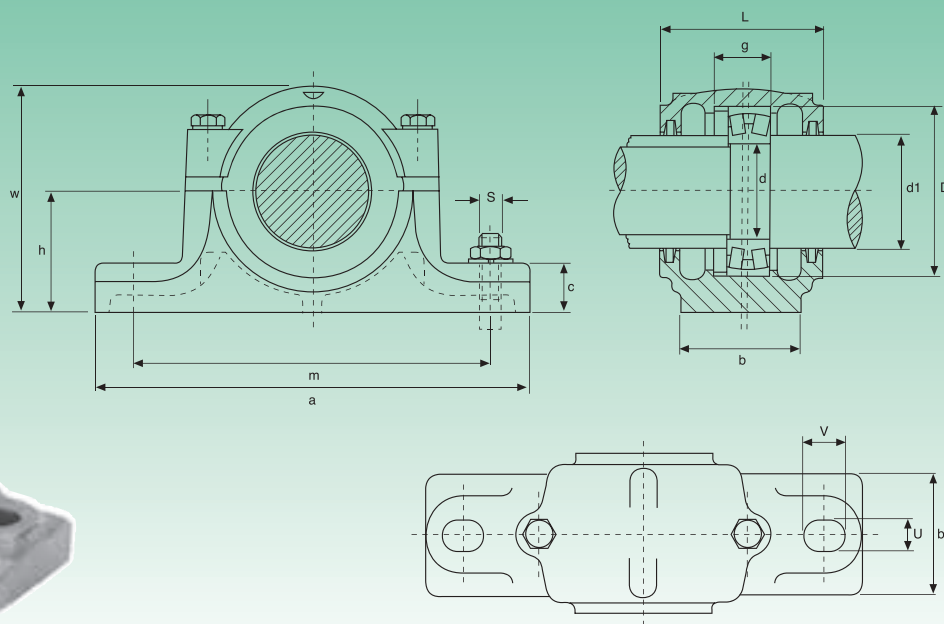

Tipo Type	Diametro albero Shaft diameter			Dimensioni - Dimensions											
	d	d0	d1	D H8	a	b	c	g H12	h h12	L ± 5	w	m	n	U	V
	mm			mm											
SN 207	35	30	45	72	185	52	22	33	50	82	95	150	-	15	20
SN 208	40	35	50	80	205	60	25	33	60	85	110	170	-	15	20
SN 209	45	40	55	85	205	60	25	31	60	85	112	170	30	15	20
SN 210	50	45	60	90	205	60	25	33	60	90	115	170	30	15	20
SN 211	55	50	65	100	255	70	28	33	70	95	130	210	35	18	23
SN 212	60	55	70	110	255	70	30	38	70	105	135	210	35	18	23
SN 213	65	60	75	120	275	80	30	43	80	110	150	230	40	18	23
SN 215	75	65	85	130	280	80	30	41	80	115	155	230	40	18	23
SN 216	80	70	90	140	315	90	32	43	95	120	175	260	50	22	27
SN 217	85	75	95	150	320	90	32	46	95	125	185	260	50	22	27
SN 218	90	80	100	160	345	100	35	62,4	100	145	195	290	50	22	27
SN 220	100	90	115	180	380	110	40	70,3	112	160	218	320	60	26	32
SN 222	110	100	125	200	410	120	45	80	125	175	240	350	70	26	32
SN 224	120	110	135	215	410	120	45	86	140	185	270	350	70	26	32
SN 226	130	115	145	230	445	130	50	90	150	190	290	380	70	28	36
SN 228	140	125	155	250	500	150	50	98	150	205	305	420	80	33	42
SN 230	150	135	165	270	530	160	60	106	160	220	325	450	90	33	42
SN 232	160	140	175	290	550	160	60	114	170	235	345	470	90	33	42

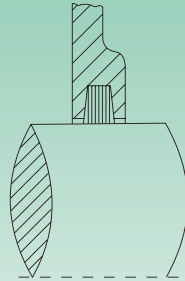
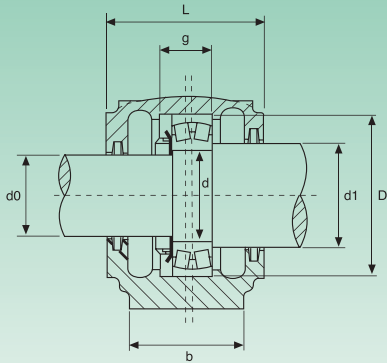

Tenuta in feltro "TSNC" per: SNG-SNU
"TSNC" felt seal for: SNG-SNU

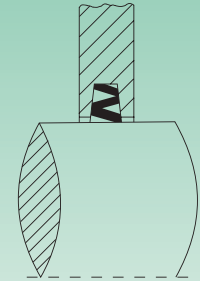

Tenuta in NBR "ZF" per: SN
"ZF" NBR seal for: SN

S		Cuscinetto orientabile a sfere Self-aligning ball bearing	Cuscinetto orientabile a rulli Self-aligning roller bearing	Ghiera di bloccaggio Lock nut KM	Rosetta Washer MB	"TSNC" Tenuta in feltro Felt seal		"ZF" Tenuta in NBR NBR seal		Anello di centraggio Locating ring		Tipo Type
2 Bull. Fiss. 2 Bolt size	4 Bull. Fiss. 4 Bolt size					d0	d1	d0	d1	Tipo Type	Q.tà Q.ty	
M 12	-	1207 2207	22207	KM 07	MB 07	TSNC 207	TSNC 210	ZF 207	ZF 210	SR 72x8 SR 72x10	2 1	SN 207
M 12	-	1208 2208	22208	KM 08	MB 08	TSNC 208	TSNC 211	ZF 208	ZF 211	SR 80x7,5 SR 80x10	2 1	SN 208
M 12	M 10	1209 2209	22209	KM 09	MB 09	TSNC 209	TSNC 212	ZF 209	ZF 212	SR 85x6 SR 85x8	2 1	SN 209
M 12	M 10	1210 2210	22210	KM 10	MB 10	TSNC 210	TSNC 213	ZF 210	ZF 213	SR 90x6,5 SR 90x10	2 1	SN 210
M 16	M 12	1211 2211	22211	KM 11	MB 11	TSNC 211	TSNC 215	ZF 211	ZF 215	SR 100x6 SR 100x8	2 1	SN 211
M 16	M 12	1212 2212	22212	KM 12	MB 12	TSNC 212	TSNC 216	ZF 212	ZF 216	SR 110x8 SR 110x10	2 1	SN 212
M 16	M 12	1213 2213	22213	KM 13	MB 13	TSNC 213	TSNC 217	ZF 213	ZF 217	SR 120x10 SR 120x12	2 1	SN 213
M 16	M 12	1215 2215	22215	KM 15	MB 15	TSNC 215	TSNC 219	ZF 215	ZF 219	SR 130x8 SR 130x10	2 1	SN 215
M 20	M 16	1216 2216	22216	KM 16	MB 16	TSNC 216	TSNC 220	ZF 216	ZF 220	SR 140x8,5 SR 140x10	2 1	SN 216
M 20	M 16	1217 2217	22217	KM 17	MB 17	TSNC 217	TSNC 221	ZF 217	ZF 221	SR 150x9 SR 150x10	2 1	SN 217
M 20	M 16	1218 2218	22218 23218	KM 18	MB 18	TSNC 218	TSNC 222	ZF 218	ZF 222	SR 160x16,2 SR 160x11,2 SR 160x10	2 2 1	SN 218
M 24	M 16	2220	22220 23220	KM 20	MB 20	TSNC 220	TSNC 226	ZF 220	ZF 226	SR 180x12,1 SR 180x10	2 1	SN 220
M 24	M 16	2222	22222 23222	KM 22	MB 22	TSNC 222	TSNC 228	ZF 222	ZF 228	SR 200x13,5 SR 200x10	2 1	SN 222
M 24	M 16	-	22224 23224	KM 24	MB 24	TSNC 224	TSNC 230	ZF 224	ZF 230	SR 215x14 SR 215x10	2 1	SN 224
M 24	M 20	-	22226 23226	KM 26	MB 26	TSNC 226	TSNC 233	ZF 226	ZF 233	SR 230x13 SR 230x10	2 1	SN 226
M 30	M 24	-	22228 23228	KM 28	MB 28	TSNC 228	TSNC 235	ZF 228	ZF 235	SR 250x15 SR 250x10	2 1	SN 228
M 30	M 24	-	22230 23230	KM 30	MB 30	TSNC 230	TSNC 237	ZF 230	ZF 237	SR 270x16,5 SR 270x10	2 1	SN 230
M 30	M 24	-	22232 23232	KM 32	MB 32	TSNC 232	TSNC 239	ZF 232	ZF 239	SR 290x17 SR 290x10	2 1	SN 232

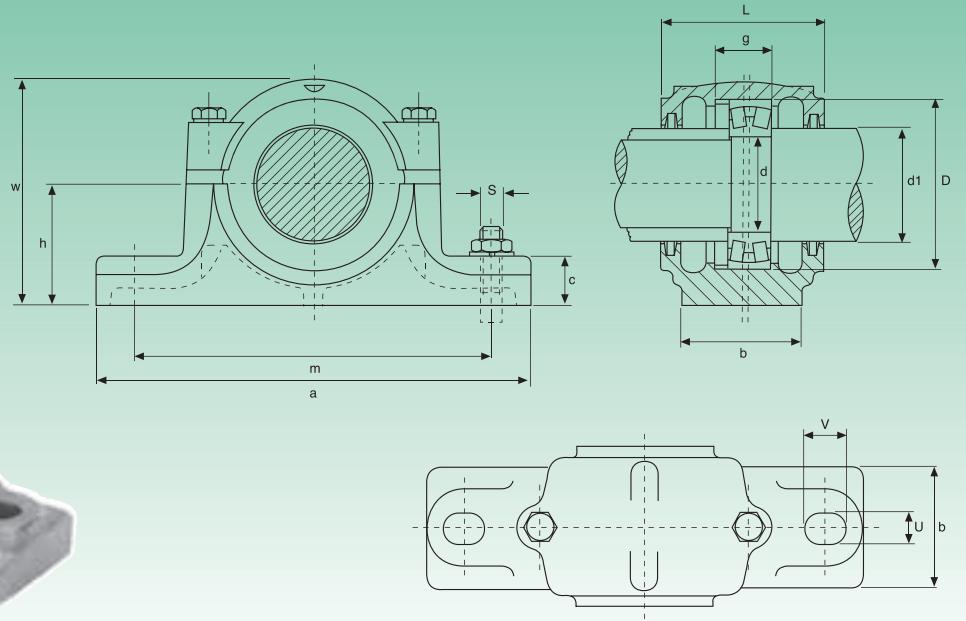

Tipo Type	Diametro albero Shaft diameter			Dimensioni - Dimensions											
	d	d0	d1	D H8	a	b	c	g H12	h h12	L ± 5	w	m	n	U	V
	mm			mm											
SN 307	35	30	45	80	205	60	25	41	60	90	110	170	-	15	20
SN 308	40	35	50	90	205	60	25	43	60	95	115	170	-	15	20
SN 309	45	40	55	100	255	70	28	46	70	105	130	210	-	18	23
SN 310	50	45	60	110	255	70	30	50	70	115	135	210	-	18	23
SN 311	55	50	65	120	275	80	30	53	80	120	150	230	40	18	23
SN 312	60	55	70	130	280	80	30	56	80	125	155	230	40	18	23
SN 313	65	60	75	140	315	90	32	58	95	130	175	260	50	22	27
SN 315	75	65	85	160	345	100	35	65	100	140	195	290	50	22	27
SN 316	80	70	90	170	345	100	35	68	112	145	212	290	50	22	27
SN 317	85	75	95	180	380	110	40	70	112	155	218	320	60	26	32
SN 318	90	80	100	190	400	110	33	74	112	160	230	320	60	26	35
SN 319	95	85	110	200	420	120	36	77	125	170	245	350	70	26	35
SN 320	100	90	115	215	420	120	38	83	140	175	280	350	70	26	35
SN 322	110	100	125	240	460	130	40	90	150	190	300	390	70	28	38
SN 324	120	110	135	260	540	160	50	96	160	205	325	450	90	33	42
SN 326	130	115	150	280	560	160	50	103	170	215	350	470	90	33	42
SN 328	140	125	160	300	630	170	55	112	180	235	375	520	90	35	45
SN 330	150	135	170	320	680	180	55	118	190	245	395	560	90	35	45
SN 332	160	140	180	340	710	190	60	124	200	255	415	580	100	42	52

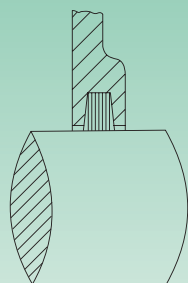
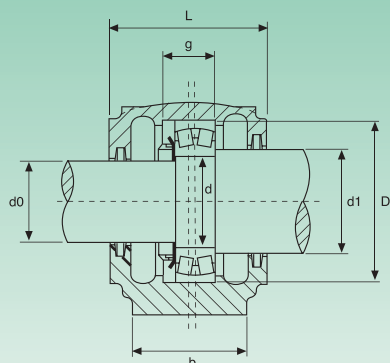

Tenuta in feltro "TSNC" per: SNG-SNU
"TSNC" felt seal for: SNG-SNU

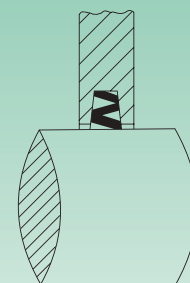

Tenuta in NBR "ZF" per: SN
"ZF" NBR seal for: SN

S		Cuscinetto orientabile a sfere Self-aligning ball bearing	Cuscinetto orientabile a rulli Self-aligning roller bearing	Ghiera di bloccaggio Lock nut	Rosetta Washer	"TSNC" Tenuta in feltro Felt seal		"ZF" Tenuta in NBR NBR seal		Anello di centraggio Locating ring		Tipo Type
2 Bull. Fiss. 2 Bolt size	4 Bull. Fiss. 4 Bolt size					KM	MB	d0	d1	d0	d1	
M 12	-	1307 2307	-	KM 07	MB 07	TSNC 307	TSNC 310	ZF 307	ZF 310	SR 80x10 SR 80x10	2 1	SN 307
M 12	-	1308 2308	21308 22308	KM 08	MB 08	TSNC 308	TSNC 311	ZF 308	ZF 311	SR 90x10 SR 90x10	2 1	SN 308
M 16	-	1309 2309	21309 22309	KM 09	MB 09	TSNC 309	TSNC 312	ZF 309	ZF 312	SR 100x10,5 SR 100x10	2 1	SN 309
M 16	-	1310 2310	21310 22310	KM 10	MB 10	TSNC 310	TSNC 313	ZF 310	ZF 313	SR 110x11,5 SR 110x10	2 1	SN 310
M 16	M 12	1311 2311	21311 22311	KM 11	MB 11	TSNC 311	TSNC 315	ZF 311	ZF 315	SR 120x12 SR 120x10	2 1	SN 311
M 16	M 12	1312 2312	21312 22312	KM 12	MB 12	TSNC 312	TSNC 316	ZF 312	ZF 316	SR 130x12,5 SR 130x10	2 1	SN 312
M 20	M 16	1313 2313	21313 22313	KM 13	MB 13	TSNC 313	TSNC 317	ZF 313	ZF 317	SR 140x12,5 SR 140x10	2 1	SN 313
M 20	M 16	1315 2315	21315 22315	KM 15	MB 15	TSNC 315	TSNC 319	ZF 315	ZF 319	SR 160x14 SR 160x10	2 1	SN 315
M 20	M 16	1316 2316	21316 22316	KM 16	MB 16	TSNC 316	TSNC 320	ZF 316	ZF 320	SR 170x14,5 SR 170x10	2 1	SN 316
M 24	M 16	1317 2317	21317 22317	KM 17	MB 17	TSNC 317	TSNC 321	ZF 317	ZF 321	SR 180x14,5 SR 180x10	2 1	SN 317
M 24	M 16	1318 2318	21318 22318	KM 18	MB 18	TSNC 318	TSNC 322	ZF 318	ZF 322	SR 190x15,5 SR 190x10	2 1	SN 318
M 24	M 16	1319 2319	21319 22319	KM 19	MB 19	TSNC 319	TSNC 324	ZF 319	ZF 324	SR 200x16 SR 200x10	2 1	SN 319
M 24	M 16	1320 2320	21320 22320	KM 20	MB 20	TSNC 320	TSNC 326	ZF 320	ZF 326	SR 215x18 SR 215x10	2 1	SN 320
M 24	M 16	1322 2322	22322	KM 22	MB 22	TSNC 322	TSNC 328	ZF 322	ZF 328	SR 240x20 SR 240x10	2 1	SN 322
M 30	M 20	-	22324	KM 24	MB 24	TSNC 324	TSNC 330	ZF 324	ZF 330	SR 260x10	1	SN 324
M 30	M 20	-	22326	KM 26	MB 26	TSNC 326	TSNC 334	ZF 326	ZF 334	SR 280x10	1	SN 326
M 30	M 20	-	22328	KM 28	MB 28	TSNC 328	TSNC 336	ZF 328	ZF 336	SR 300x10	1	SN 328
M 30	M 20	-	22330	KM 30	MB 30	TSNC 330	TSNC 338	ZF 330	ZF 338	SR 320x10	1	SN 330
M 36	M 24	-	22332	KM 32	MB 32	TSNC 332	TSNC 340	ZF 332	ZF 340	SR 340x10	1	SN 332

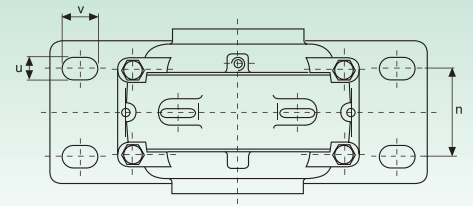
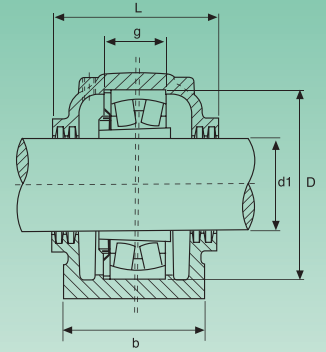
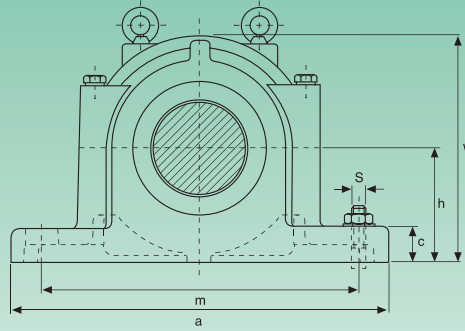
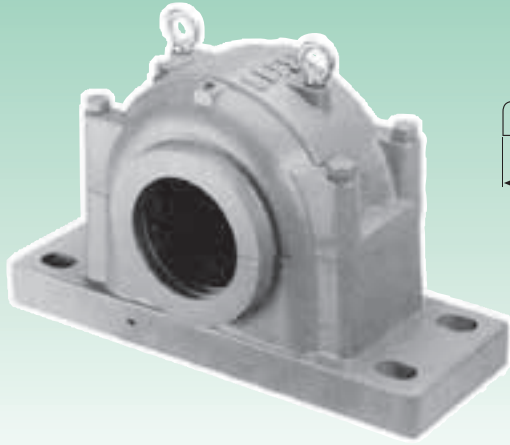

Tipo Type	Diametro albero Shaft diameter	Dimensioni - Dimensions											
	d1	D H8	a	b	c	g H12	h h12	L ± 5	w	m	n	U	V
	mm	mm											
SD 3034	150	260	540	200	50	77	160	230	320	450	110	36	52
SD 3036	160	280	560	220	50	84	170	250	340	470	120	36	52
SD 3038	170	290	560	220	50	85	170	250	345	470	120	36	52
SD 3040	180	310	620	230	60	92	180	270	360	510	140	36	52
SD 3044	200	340	700	260	65	100	200	290	400	570	160	36	55
SD 3048	220	360	740	270	65	102	210	300	420	610	170	36	55
SD 3052	240	400	820	300	70	114	240	330	475	680	190	43	62
SD 3056	260	420	860	320	85	116	250	350	500	710	200	43	62
SD 3060	280	460	920	330	85	128	280	360	550	770	210	43	62
SD 3064	300	480	940	340	85	131	280	370	560	790	210	43	62
SD 3068	320	520	1020	370	100	143	310	400	615	860	230	50	70
SD 3072	340	540	1060	390	100	144	325	410	640	890	250	50	70
SD 3076	360	560	1080	390	100	145	340	410	665	900	260	50	70

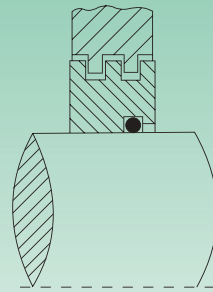
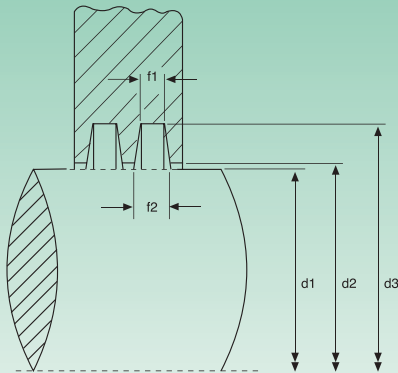

Tenuta a labirinto "TS" per: SN-SD
"TS" labyrinth seal for: SN-SD

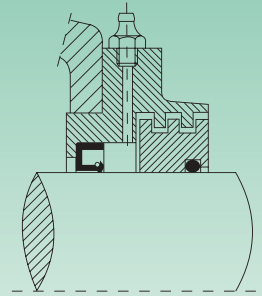

Chiusura di taconite "TAC" per: SN-SD
"TAC" taconite cover for: SN-SD

Bull. fiss. Bolt Size	Dimensioni - Dimensions				Peso Weight	Cuscinetto orientabile a rulli (foro conico) Self-aligning roller bearing (conical bore)	Bussola (metrica) Adapter sleeve (metric)	Anello di centraggio Locating ring		"TS" Tenuta a labirinto Labyrinth seal	"ETS" Coperchio Cover
	d2 H12	d3 H12	f1 H13	f2				Tipo Type	Q.tà Q.ty		
S	mm				kg						
M 30	153	183	10	13,8	62	23034 K	H 3034	SR 260x10	1	TS 3034	ETS 3034
M 30	163	193	10	13,8	78	23036 K	H 3036	SR 280x10	1	TS 3036	ETS 3036
M 30	173	203	10	13,8	82	23038 K	H 3038	SR 290x10	1	TS 3038	ETS 3038
M 30	183	213	10	13,8	92	23040 K	H 3040	SR 310x10	1	TS 3040	ETS 3040
M 30	203	240	11	15,7	125	23044 K	H 3044	SR 340x10	1	TS 3044	ETS 3044
M 30	223	260	11	15,7	140	23048 K	H 3048	SR 360x10	1	TS 3048	ETS 3048
M 36	243	286	12	17,4	200	23052 K	H 3052	SR 400x10	1	TS 3052	ETS 3052
M 36	263	306	12	17,4	230	23056 K	H 3056	SR 420x10	1	TS 3056	ETS 3056
M 36	283	332	13	19,1	290	23060 K	H 3060	SR 460x10	1	TS 3060	ETS 3060
M 36	303	352	13	19,1	300	23064 K	H 3064	SR 480x10	1	TS 3064	ETS 3064
M 42	323	372	13	19,1	400	23068 K	H 3068	SR 520x10	1	TS 3068	ETS 3068
M 42	343	392	13	19,1	450	23072 K	H 3072	SR 540x10	1	TS 3072	ETS 3072
M 42	363	412	13	19,1	470	23076 K	H 3076	SR 560x10	1	TS 3076	ETS 3076

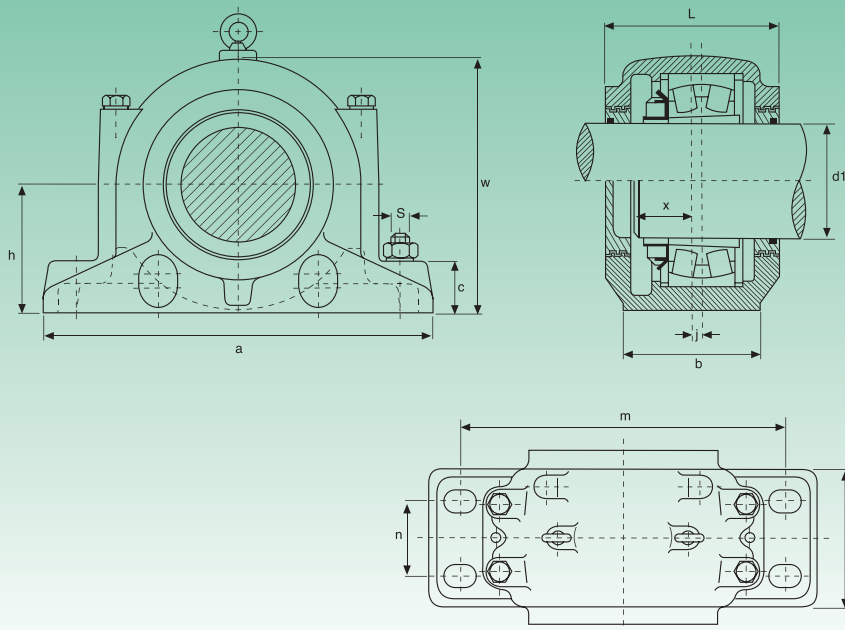

Tipo Type	Diametro albero Shaft diameter		Dimensioni - Dimensions												
	d1		D H8	a	b	c	g H12	h h12	L ± 5	L2	w	m	n	U	U
	mm	inch	mm												
SD 3134	150	6	280	510	180	70	108	170	230	308	335	430	100	30	36
SD 3136	160	6½	300	530	190	75	116	180	240	318	355	450	110	30	36
SD 3138	170	6¾	320	560	210	80	124	190	260	336	375	480	120	30	38
SD 3140	180	7	340	610	230	85	132	210	280	356	410	510	130	35	40
SD 3144	200	-	370	640	240	90	140	220	290	368	435	540	140	35	40
SD 3148	220	-	400	700	260	95	148	240	310	388	475	600	150	35	40
SD 3152	240	-	440	770	280	100	164	260	320	400	515	650	160	40	48
SD 3156	260	-	460	790	280	105	166	280	320	400	550	670	160	42	50
SD 3160	280	-	500	830	310	110	180	300	350	426	590	710	190	42	60
SD 3164	300	-	540	880	330	115	196	320	370	448	630	750	200	42	60
SD 3168	320	-	580	965	380	120	210	340	390	488	670	840	240	49	59
SD 3172	340	-	600	1040	390	130	212	360	390	498	720	890	255	49	59
SD 3176	360	-	620	1120	400	135	214	380	405	520	750	980	255	60	72
SD 3180	380	-	650	1245	420	140	220	400	425	543	790	1050	270	65	78

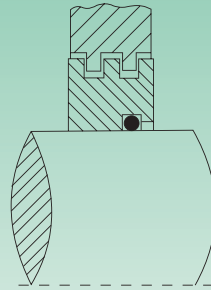
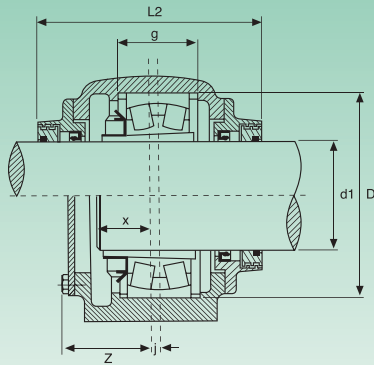

Tenuta a labirinto "TS" per: SN-SD
"TS" labyrinth seal for: SN-SD

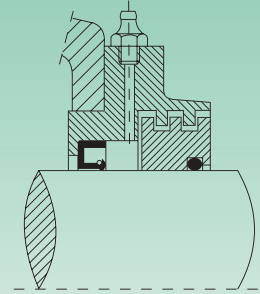

Chiusura di taconite "TAC" per: SN-SD
"TAC" taconite cover for: SN-SD

Dimensioni - Dimensions			Bull. fiss. Bolt Size	Peso Weight	Cuscinetto orientabile a rulli (foro conico) Self-aligning roller bearing (conical bore)	Bussola Adapter sleeve		Anello di centraggio Locating ring		"TS" Tenuta a labirinto Labyrinth seal	"ETS" Coperchio Cover	"TAC" Chiusura di taconite Taconite cover
J	X	Z				S	mm	inch	Tipo Type			
mm				kg								
14	65	120	M 24	70	23134 K	H 3134	HE 3134	SR 280x10	2	TS 3134	ETS 3134	TAC 3134
15	68	130	M 24	72	23136 K	H 3136	HE 3136	SR 300x10	2	TS 3136	ETS 3136	TAC 3136
10	80	140	M 24	88	23138 K	H 3138	HE 3138	SR 320x10	2	TS 3138	ETS 3138	TAC 3138
10	82	150	M 30	122	23140 K	H 3140	HE 3140	SR 340x10	2	TS 3140	ETS 3140	TAC 3140
12	90	155	M 30	136	23144 K	H 3144	-	SR 370x10	2	TS 3144	ETS 3144	TAC 3144
12	100	160	M 30	190	23148 K	H 3148	-	SR 400x10	2	TS 3148	ETS 3148	TAC 3148
13	105	170	M 36	238	23152 K	H 3152	-	SR 440x10	2	TS 3152	ETS 3152	TAC 3152
16	105	170	M 36	252	23156 K	H 3156	-	SR 460x10	2	TS 3156	ETS 3156	TAC 3156
22	110	190	M 36	290	23160 K	H 3160	-	SR 500x10	2	TS 3160	ETS 3160	TAC 3160
23	120	200	M 36	340	23164 K	H 3164	-	SR 540x10	2	TS 3164	ETS 3164	TAC 3164
25	135	220	M 45	430	23168 K	H 3168	-	SR 580x10	2	TS 3168	ETS 3168	TAC 3168
22	145	225	M 50	560	23172 K	H 3172	-	SR 600x10	2	TS 3172	ETS 3172	TAC 3172
22	145	240	M 55	770	23176 K	H 3176	-	SR 620x10	2	TS 3176	ETS 3176	TAC 3176
22	150	260	M 60	870	23180 K	H 3180	-	SR 650x10	2	TS 3180	ETS 3180	TAC 3180

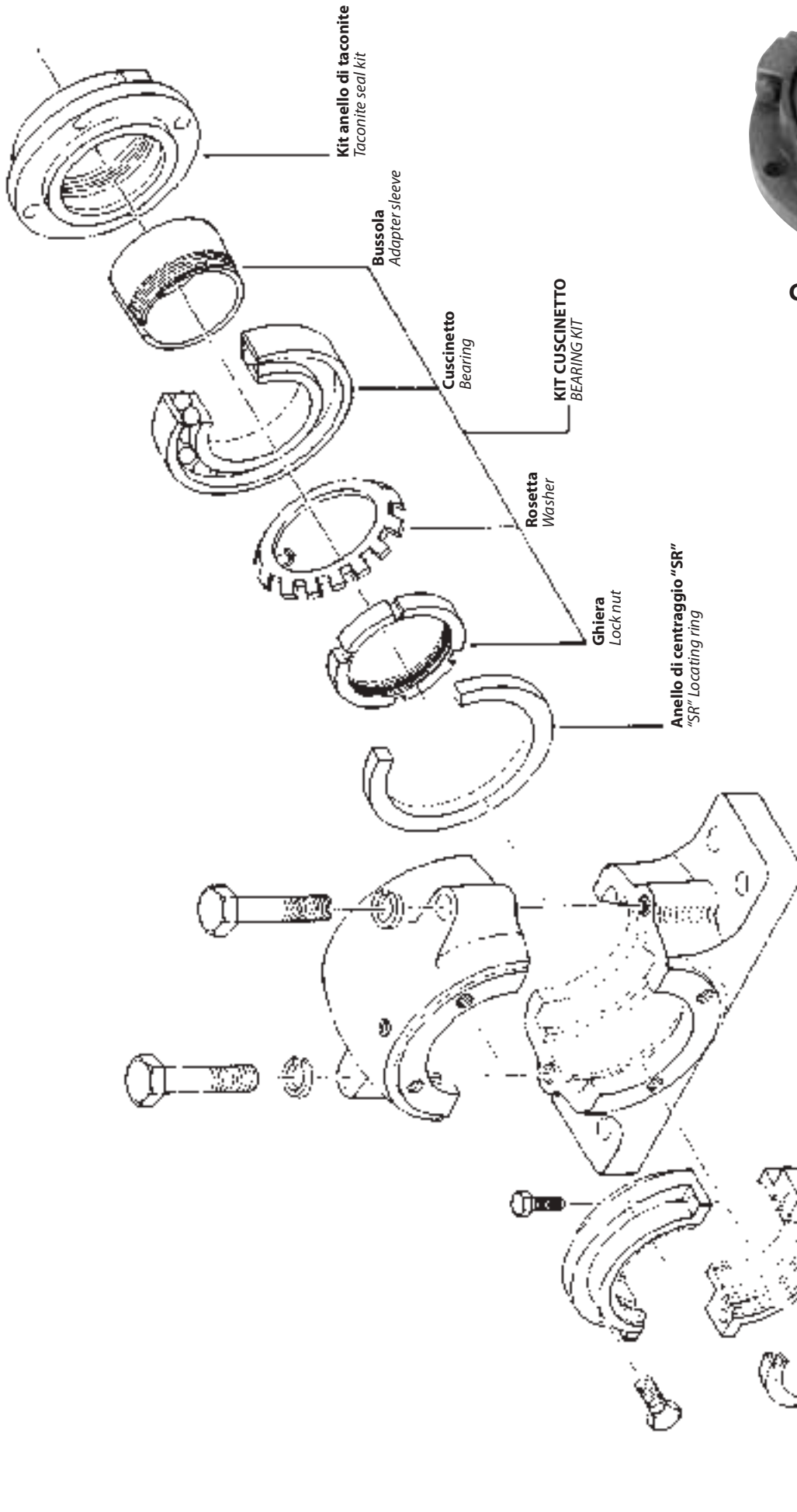

CHIUSURA DI TACONITE
TACONITE COVER

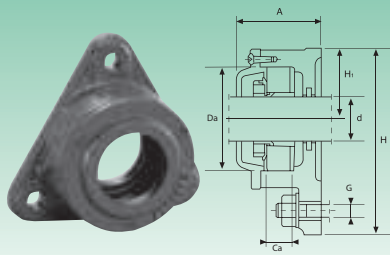

DB coperchio aperto - Open cover

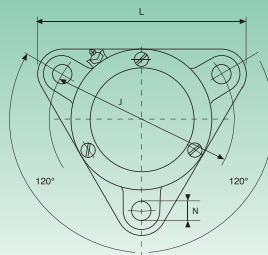

DA coperchio chiuso - Closed cover

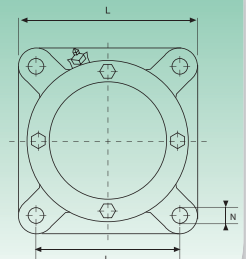
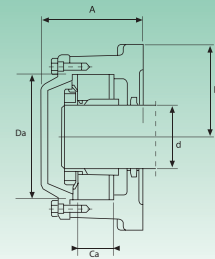

Tipo Type	Dimensioni - Dimensions										Peso Weight kg	Cuscinetti appropriati - Suitable bearings			Forma flangia Flange
	d	A	L	H	H ₁	N	J	Da	Ca	G		Cuscinetti orientabile a sfere Self-aligning ball bearings	Anello d'arresto Locating ring		
	mm											Cuscinetti orientabile a rulli Cylindrical roller bearings			
722505 DA	20	51,5	110	100	38	11,5	96	52	20	10	1,10	1205 K 22205 K	2205 K	SR52x5 SR52x2	▲
722505 DB	20	56,5	110	100	38	11,5	96	52	20	10	1,10	1205 K 22205 K	2205 K	SR52x5 SR52x2	▲
722506 DA	25	57	130	117	44	11,5	116	62	22	10	1,50	1206 K 22206 K	2206 K	SR62x6 SR62x2	▲
722506 DB	25	59,5	130	117	44	11,5	116	62	22	10	1,50	1206 K 22206 K	2206 K	SR62x6 SR62x2	▲
722507 DA	30	59,5	145	129,5	48,5	14	130	72	25	12	1,80	1207 K 22207 K	2207 K	SR72x8 SR72x2	▲
722507 DB	30	63,5	145	129,5	48,5	14	130	72	25	12	1,80	1207 K 22207 K	2207 K	SR72x8 SR72x2	▲
722508 DA	35	64	160	143	54	14	140	80	25	12	2,30	1208 K 22208 K	2208 K	SR80x7 SR80x2	▲
722508 DB	35	65,5	160	143	54	14	140	80	25	12	2,30	1208 K 22208 K	2208 K	SR80x7 SR80x2	▲
722509 DA	40	64,5	180	160	60	14	160	85	25	12	3,0	1209 K 22209 K	2209 K	SR85x6 SR85x2	▲
722509 DB	40	69,5	180	160	60	14	160	85	25	12	3,0	1209 K 22209 K	2209 K	SR85x6 SR85x2	▲
722510 DA	45	68,5	180	160	60	14	160	90	25	12	3,0	1210 K 22210 K	2210 K	SR90x5 SR90x2	▲
722510 DB	45	73	180	160	60	14	160	90	25	12	3,0	1210 K 22210 K	2210 K	SR90x5 SR90x2	▲
722511 DA	50	75,5	192	172,5	65	14	170	100	27	12	4,10	1211 K 22211 K	2211 K	SR100x6 SR100x2	▲
722511 DB	50	81,5	192	172,5	65	14	170	100	27	12	4,10	1211 K 22211 K	2211 K	SR100x6 SR100x2	▲
722512 DA	55	77	210	189	72	14	180	110	30	12	4,80	1212 K 22212 K	2212 K	SR110x8 SR110x2	▲
722512 DB	55	82	210	189	72	14	180	110	30	12	4,80	1212 K 22212 K	2212 K	SR110x8 SR110x2	▲
722513 DA	60	80	225	203	78	14	190	120	33	12	5,90	1213 K 22213 K	2213 K	SR120x10 SR120x2	▲
722513 DB	60	86	225	203	78	14	190	120	33	12	5,90	1213 K 22213 K	2213 K	SR120x10 SR120x2	▲
722515 A	65	104	190	190	95	18	152	130	41	16	9,40	1215 K 22215 K	2215 K	SR130x8 SR130x10	■
722515 B	65	104	190	190	95	18	152	130	41	16	9,40	1215 K 22215 K	2215 K	SR130x8 SR130x10	■
722516 A	70	110	196	196	98	18	152	140	43	16	9,80	1216 K 22216 K	2216 K	SR140x8,5 SR140x10	■
722516 B	70	110	196	196	98	18	152	140	43	16	9,80	1216 K 22216 K	2216 K	SR140x8,5 SR140x10	■
722517 A	75	114	210	210	105	18	170	150	46	16	11,5	1217 K 22217 K	2217 K	SR150x9 SR150x10	■
722517 B	75	114	210	210	105	18	170	150	46	16	11,5	1217 K 22217 K	2217 K	SR150x9 SR150x10	■
722518 A	80	118	210	210	105	18	170	160	50	16	12,5	1218 K 22218 K	2218 K	SR160x10 SR160x10	■
722518 B	80	118	210	210	105	18	170	160	50	16	12,5	1218 K 22218 K	2218 K	SR160x10 SR160x10	■
722520 A	90	127	250	250	125	22	198	180	56	20	18,0	1220 K 22220 K	2220 K	SR180x11 SR180x10	■
722520 B	90	127	250	250	125	22	198	180	56	20	18,0	1220 K 22220 K	2220 K	SR180x11 SR180x10	■
722522 A	100	137	270	270	135	22	219	200	63	20	21,5	1222 K 22222 K	2222 K	SR200x12,5 SR200x10	■
722522 B	100	137	270	270	135	22	219	200	63	20	21,5	1222 K 22222 K	2222 K	SR200x12,5 SR200x10	■

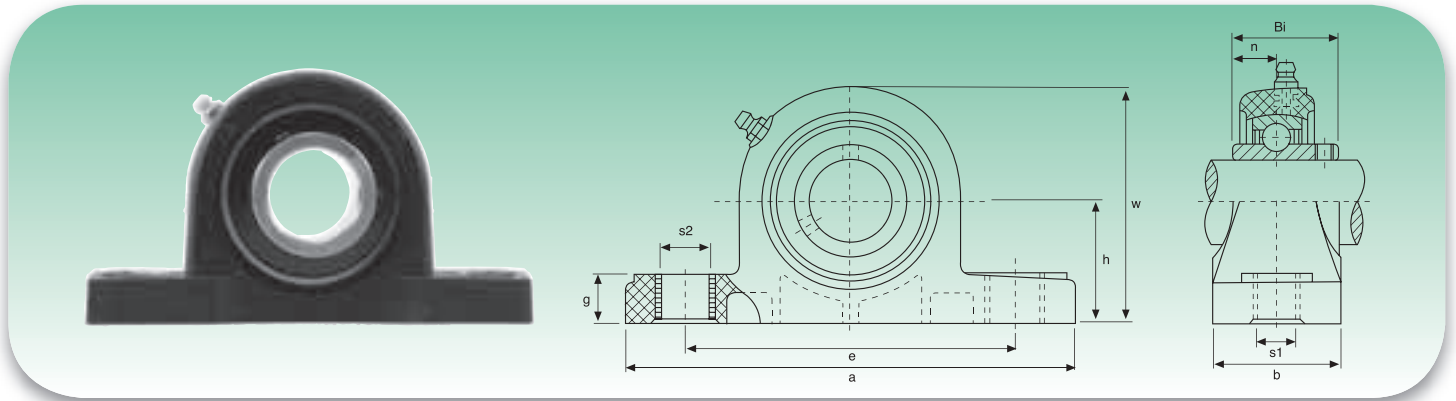
UCP

Tipo Type	Diametro albero Shaft diameter		Dimensioni - Dimensions										Peso Weight kg	Bull. fiss. Bolt Size	Coppia (Nm) Torque (Nm)
			a	h	e	b	s1	s2	g	w	Bi	n			
	mm	inch	mm												
UCP 204	20	¾	127	33,3	95	37,5	11	14	14,2	65,5	31	12,7	0,13	M10	18
UCP 205	25	13/16 7/8 15/16 1	140,5	36,5	105	38	11	14	14,5	71	34	14,3	0,14	M10	25
UCP 206	30	11/16 11/8 13/16 1¼	163	42,9	119	46	15	18	18	84	38,1	15,9	0,24	M12	30
UCP 207	35	1¼ 15/16 13/8 17/16	168	47,6	127	48	15	18	18	94,5	42,9	17,5	0,27	M12	35
UCP 208	40	1½ 19/16	184	49,2	137	54	15	18	20	98	49,2	19	0,35	M12	45
UCP 209	45	15/8 111/16 1¾	192	54	146	54	17	20	25	106	49,2	19	0,41	M16	50
UCP 210	50	113/16 17/8 115/16 2	206	57,2	159	59	17	20	24	114	51,6	19	0,47	M16	55
UCP 211	55	2 21/16 21/8 23/16	219	63,5	171	60	17	20	23	125	55,6	22,2	0,58	M16	60
UCP 212	60	2¼ 25/16 23/8 27/16	241	69,8	184	70	17	20	26	136	65,1	25,4	0,68	M16	65

Modalità di caricamento Mode of load	Coefficients di carico (N) - Load ratings (N)									
	Tipo Type	204	205	206	207	208	209	210	211	212
		8 800	13 700	12 650	12 750	13 100	13 360	13 850	14 540	15 270
		7 700	10 000	10 600	10 800	11 100	11 400	11 750	11 970	12 570
		5 000	8 100	5 750	7 500	8 500	8 950	9 550	10 027	10 530

Caratteristiche

- Materiale: PBT (disponibili in color bianco, nero e verde)
- Intercambiabile con supporti in ghisa
- Ingrassatori d'acciaio inox aisi 304
- Temperatura d'esercizio: da -35°C a +102°C
- Coperchio d'estremità
- Guarnizioni interne
- Resistenza chimica (pag. 150)

Characteristics

- Material: PBT (white, black and green colours available)
- Interchangeable with cast iron housing
- Stainless steel aisi 304 greasers
- Working temperature: from -35°C to +102°C
- End cover
- Back seals
- Chemical resistance (pag. 150)

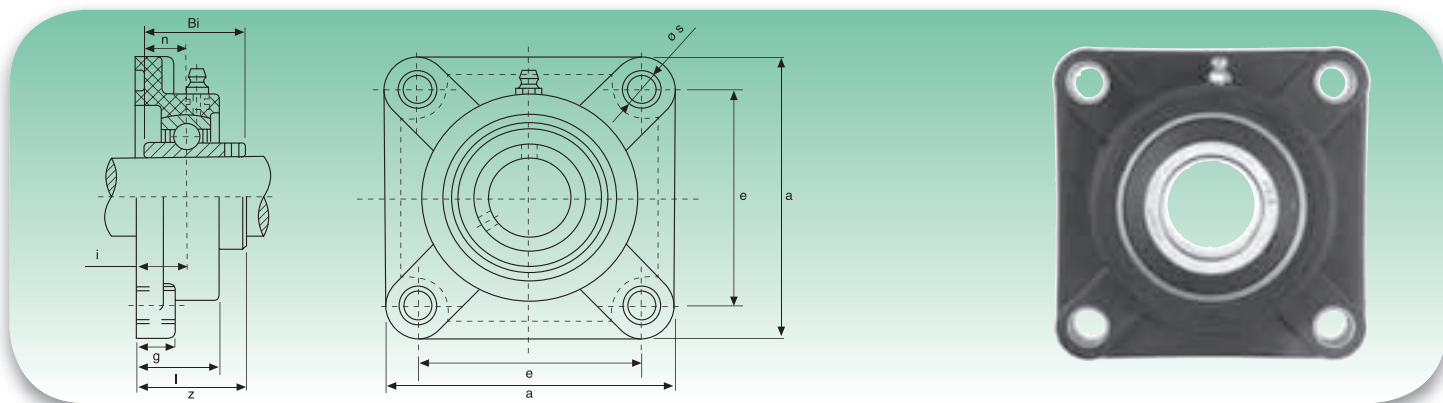

Tipo Type	Diametro albero Shaft diameter		Dimensioni - Dimensions									Peso Weight	Bull. fiss. Bolt Size	Coppia (Nm) Torque (Nm)
			a	e	g	l	s	z	i	Bi	n			
	mm	inch	mm									kg		
UCF 201	12	1/2	86	63,5	13,4	27,8	11	34,6	16,3	31	12,7	0,12	M10	18
UCF 202	15	9/16 5/8	86	63,5	13,4	27,8	11	34,6	16,3	31	12,7	0,12	M10	18
UCF 203	17	11/16	86	63,5	13,4	27,8	11	34,6	16,3	31	12,7	0,12	M10	18
UCF 204	20	3/4	86	63,5	14,5	28	11	34,6	16,3	31	12,7	0,12	M10	18
UCF 205	25	13/16 7/8 15/16 1	95	70	15	29	11	36,7	17	34	14,3	0,15	M10	25
UCF 206	30	11/16 11/8 13/16 1 1/4	107	83	15	31,5	11	41,2	19	38,1	15,9	0,18	M10	30
UCF 207	35	1 1/4 15/16 13/8 17/16	118	92	16	34,5	13	46,9	21,5	42,9	17,5	0,25	M12	35
UCF 208	40	1 1/2 19/16	130	102	18	36,5	14	53,2	23	49,2	19	0,36	M12	40
UCF 209	45	15/8 111/16 1 3/4	137	105	19	41	17	54,2	24	49,2	19	0,42	M16	45
UCF 210	50	113/16 17/8 115/16 2	143	111	21	41	17	57,6	25	51,6	19	0,49	M16	50
UCF 211	55	21/16 21/8 23/16	162	130	20	42	19	58,4	26	55,6	22,2	0,59	M16	55
UCF 212	60	2 1/4 25/16 23/8 27/16	175	142	23	45	19	68,7	27	65,1	25,1	0,71	M16	60

Modalità di caricamento Mode of load	Coefficienti di carico (N) - Load ratings (N)									
	Tipo Type	204	205	206	207	208	209	210	211	212
		15 950	13 000	18 000	18 500	19 100	19 350	19 650	20 630	21 660
		10 250	12 150	17 700	18 500	19 250	19 350	19 620	20 600	21 630
		3 650	3 350	3 350	3 520	3 790	3 850	3 990	4 190	4 400

Caratteristiche

- Materiale: PBT (disponibili in color bianco, nero e verde)
- Intercambiabile con supporti in ghisa
- Ingrassatori d'acciaio inox aisi 304
- Temperatura d'esercizio: da -35°C a +102°C
- Coperchio d'estremità
- Guarnizioni interne
- Resistenza chimica (pag. 150)

Characteristics

- Material: PBT (white, black and green colours available)
- Interchangeable with cast iron housing
- Stainless steel aisi 304 greasers
- Working temperature: from -35°C to +102°C
- End cover
- Back seals
- Chemical resistance (pag. 150)

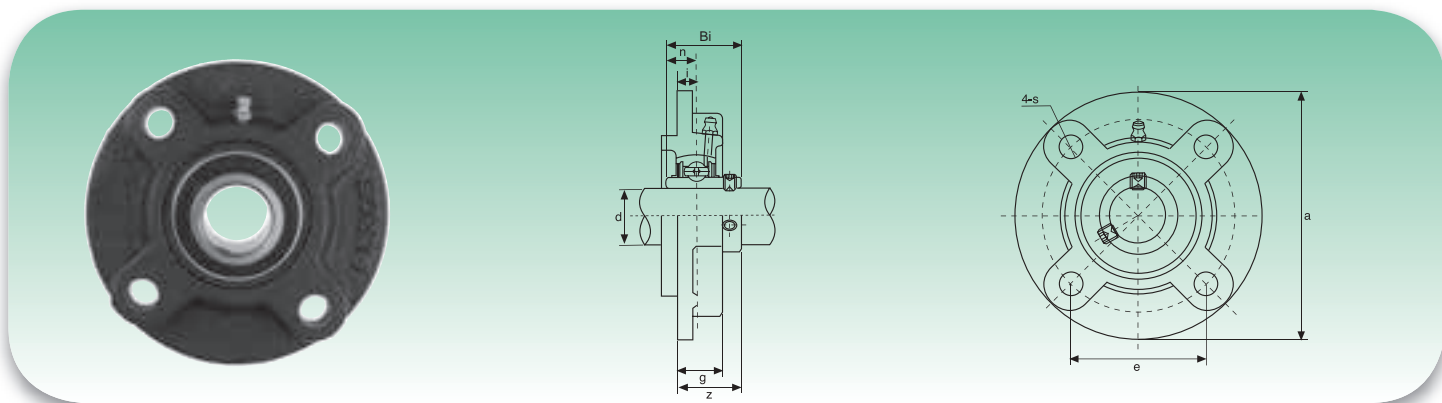

Tipo Type	Diametro albero Shaft diameter		Dimensioni - Dimensions								Peso Weight	Bull. fiss. Bolt Size	Coppia (Nm) Torque (Nm)
			a	e	g	s	z	i	Bi	n			
	mm	inch	mm								kg		
UCFC 204	20	¾	100	55,1	20,5	12	28,3	10	31	12,7	0,14	M10	18
UCFC 205	25	13/16 7/8 15/16 1	115	63,6	21	12	29,7	10	34,1	14,3	0,19	M10	25
UCFC 206	30	11/16 11/8 13/16 1¼	125	70,7	23	12	32,2	10	38,1	15,9	0,26	M10	30
UCFC 207	35	1¼ 15/16 13/8 17/16	135	77,8	26	14	36,4	11	42,9	17,5	0,36	M12	35
UCFC 208	40	1½ 19/16	145	84,8	26	14	40,2	11	49,2	19	0,40	M12	40
UCFC 209	45	15/8 111/16 1¾	160	93,3	26	16	41,2	10	49,2	19	0,58	M14	45
UCFC 210	50	113/16 17/8 115/16 2	165	97,6	28	16	42,6	10	51,6	19	0,58	M14	50
UCFC 211	55	2 21/16 21/8 23/16	185	106,1	31	19	46,4	13	55,6	22,2	-	M16	55
UCFC 212	60	2¼ 25/16 25/8 27/16	195	113,1	36	19	56,7	17	65,1	25,4	-	M16	60

Modalità di caricamento Mode of load	Coefficients di carico (N) - Load ratings (N)									
Tipo Type	204	205	206	207	208	209	210	211	212	
	15 950	13 000	18 000	18 500	19 100	19 350	19 650	20 630	21 660	
	10 250	12 150	17 700	18 500	19 250	19 350	19 620	20 600	21 630	

Caratteristiche

- Materiale: PBT (**disponibili in color bianco, nero e verde**)
- Intercambiabile con supporti in ghisa
- Ingrassatori d'acciaio inox aisi 304
- Temperatura d'esercizio: da -35°C a +102°C
- Coperchio d'estremità
- Guarnizioni interne
- Resistenza chimica (pag. 150)

Characteristics

- Material: PBT (**white, black and green colours available**)
- Interchangeable with cast iron housing
- Stainless steel aisi 304 greasers
- Working temperature: from -35°C to +102°C
- End cover
- Back seals
- Chemical resistance (pag. 150)

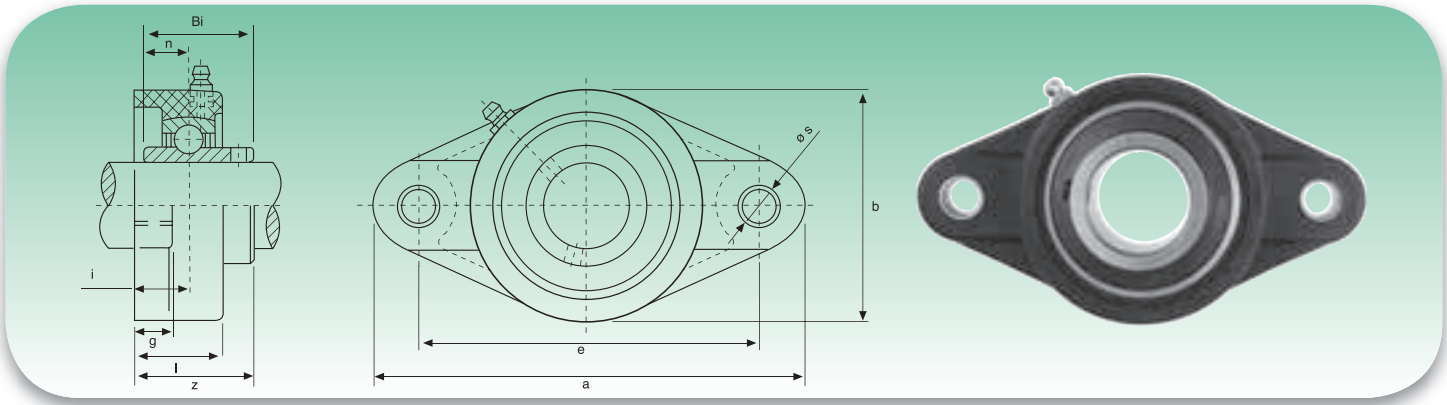

Tipo Type	Diametro albero Shaft diameter		Dimensioni - Dimensions										Peso Weight	Bull. fiss. Bolt Size	Coppia (Nm) Torque (Nm)
			a	e	b	g	l	s	z	i	Bi	n			
	mm	inch	mm										kg		
UCFL 201	12	½	113	90	65	13,4	26,5	11	33,3	15	31	12,7	0,08	M10	18
UCFL 202	15	9/16 5/8	113	90	65	13,4	26,5	11	33,3	15	31	12,7	0,08	M10	18
UCFL 203	17	11/16	113	90	65	13,4	26,5	11	33,3	15	31	12,7	0,08	M10	18
UCFL 204	20	¾	113	90	65	14	26,5	11	33,3	15	31	12,7	0,08	M10	18
UCFL 205	25	13/16 7/8 15/16 1	131	99	70	15	28	11	36,2	16,5	34	14,3	0,11	M10	25
UCFL 206	30	11/16 11/8 13/16 1¼	148	117	80	14,3	30,5	11	40,2	18	38,1	15,9	0,13	M10	30
UCFL 207	35	1¼ 15/16 13/8 17/16	164	130	90	15,5	32	13	44,4	19	42,9	17,5	0,16	M12	35
UCFL 208	40	1½ 19/16	176	144	100	17	35	14	51,7	21,5	49,2	19	0,22	M12	40
UCFL 209	45	15/8 111/16 1¾	189	149	108	22,5	40,5	17	54,2	24	49,2	19	0,26	M16	45
UCFL 210	50	113/16 17/8 115/16 2	197	157	115	22	41	17	57,6	25	51,6	19	0,31	M16	50
UCFL 211	55	2 21/16 21/8 23/16	224	184	129	18	43	19	58,4	26	55,6	22,2	0,54	M16	55
UCFL 212	60	2¼ 25/16 25/8 27/16	250	202	140	24	45	19	68,7	27	65,1	25,4	0,56	M16	60

Modalità di caricamento Mode of load	Coefficients di carico (N) - Load ratings (N)									
	204	205	206	207	208	209	210	211	212	
	11 750	11 375	16 450	16 900	17 350	17 600	17 950	18 850	19 790	
	11 000	13 850	13 350	13 950	14 050	14 300	14 550	15 280	16 040	
	8 500	11 100	14 200	14 900	15 150	15 350	15 650	16 430	17 250	

Caratteristiche

- Materiale: PBT (**disponibili in color bianco, nero e verde**)
- Intercambiabile con supporti in ghisa
- Ingrassatori d'acciaio inox aisi 304
- Temperatura d'esercizio: da -35°C a +102°C
- Coperchio d'estremità
- Guarnizioni interne
- Resistenza chimica (pag. 150)

Characteristics

- Material: PBT (**white, black and green colours available**)
- Interchangeable with cast iron housing
- Stainless steel aisi 304 greasers
- Working temperature: from -35°C to +102°C
- End cover
- Back seals
- Chemical resistance (pag. 150)

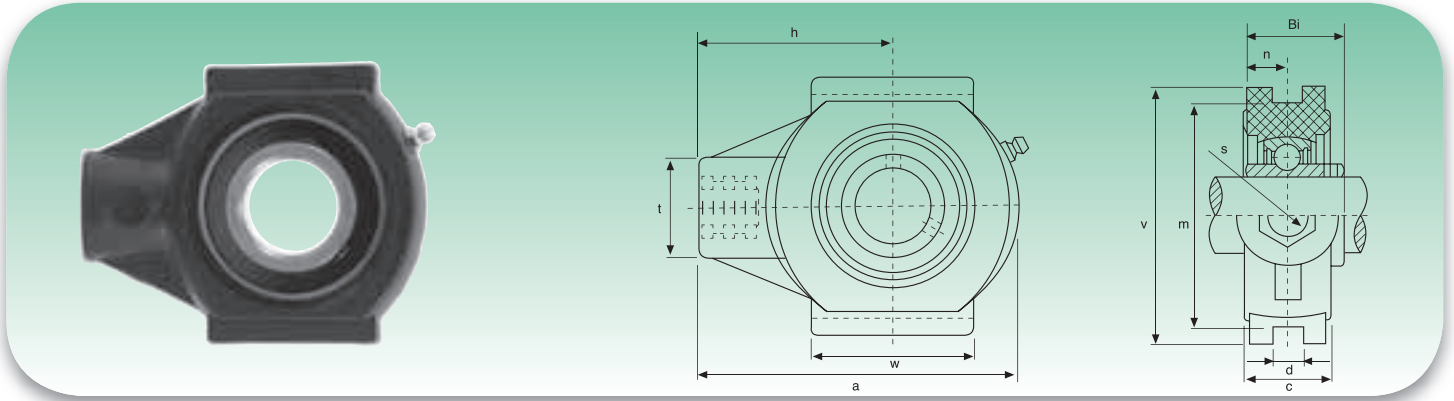
UCT

Tipo Type	Diametro albero Shaft diameter		Dimensioni - Dimensions										Peso Weight	Bull. fiss. Bolt Size
			a	c	d	h	m	t	v	w	Bi	n		
	mm	inch	mm										kg	S
UCT 201	12	½	99	27,5	12	64	76	36	88	47	31	11,5	0,18	M16
UCT 202	15	9/16 5/8	99	27,5	12	64	76	36	88	47	31	11,5	0,18	M16
UCT 203	17	11/16	99	27,5	12	64	76	36	88	47	31	11,5	0,18	M16
UCT 204	20	¾	99	27,5	12	64	76	36	88	47	31	11,5	0,18	M16
UCT 205	25	13/16 7/8 15/16 1	99	27,5	12	64	76	36	88	47	34,1	11,5	0,18	M16
UCT 206	30	11/16 11/8 13/16 1¼	125	34	12	76	89	40	102	63	38,1	15,9	0,28	M16
UCT 207	35	1¼ 15/16 13/8 17/16	125	34	12	76	89	40	102	63	42,9	15,9	0,28	M16
UCT 208	40	1½ 19/16	140	40	16	85	102	40	113	80	49,2	19	0,36	M16
UCT 209	45	15/8 111/16 1¼	149	40	16	90	102	50	117	85	49,2	19	0,41	M20
UCT 210	50	113/16 17/8 115/16 2	149	40	16	90	102	50	117	85	51,6	19	0,47	M20
UCT 211	55	2 21/16 21/8 23/16	171	38	22	106	130	64	146	95	55,6	19	-	M20
UCT 212	60	2¼ 25/16 23/8 27/16	194	42	22	119	130	64	146	102	65,1	21	-	M20

Modalità di caricamento Mode of load	Coefficienti di carico (N) - Load ratings (N)									
Tipo Type	204	205	206	207	208	209	210	211	212	
	14 800	15 500	15 800	16 500	17 300	18 210	18 860	19 800	20 790	
	3 930	4 530	5 100	6 500	7 800	8 710	9 750	10 240	10 750	
	8 500	10 350	10 900	11 300	12 150	12 900	13 550	14 230	14 940	
	40 770	45 300	46 100	44 100	42 800	44 230	44 880	47 120	49 470	

Caratteristiche

- Materiale: PBT (**disponibili in color bianco, nero e verde**)
- Intercambiabile con supporti in ghisa
- Ingrassatori d'acciaio inox aisi 304
- Temperatura d'esercizio: da -35°C a +102°C
- Coperchio d'estremità
- Guarnizioni interne
- Resistenza chimica (pag. 150)

Characteristics

- Material: PBT (**white, black and green colours available**)
- Interchangeable with cast iron housing
- Stainless steel aisi 304 greasers
- Working temperature: from -35°C to +102°C
- End cover
- Back seals
- Chemical resistance (pag. 150)

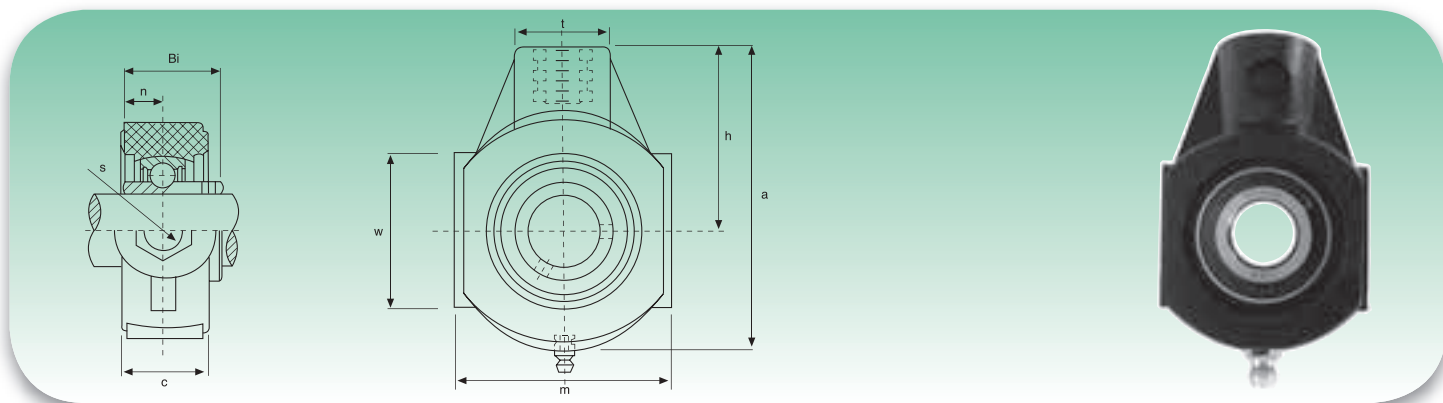

Tipo Type	Diametro albero Shaft diameter		Dimensioni - Dimensions								Peso Weight	Bull. fiss. Bolt Size
			a	c	h	m	t	w	Bi	n		
	mm	inch	mm								kg	S
UCECH 201	12	1/2	99	27,5	63,5	65	36	47	31	12,7	0,18	M16
UCECH 202	15	9/16 5/8	99	27,5	63,5	65	36	47	31	12,7	0,18	M16
UCECH 203	17	11/16	99	27,5	64	65	36	47	31	12,7	0,18	M16
UCECH 204	20	3/4	99	23	64	65	36	46	31	12,7	0,18	M16
UCECH 205	25	13/16 7/8 15/16 1	99	24	63,5	74	36	47	34	14,3	0,17	M16
UCECH 206	30	11/16 11/8 13/16 1 1/4	125	27,5	76	90	40	63	38,1	15,9	0,27	M16
UCECH 207	35	1 1/4 15/16 13/8 17/16	125	28	76	90	40	63	42,9	17,5	0,28	M16
UCECH 208	40	1 1/2 19/16	140	29	85	100	40	80	49,2	19	0,36	M16
UCECH 209	45	15/8 111/16 1 1/4	149	40	90	110	50	85	49,2	19	0,41	M20
UCECH 210	50	113/16 17/8 115/16 2	149	40	90	110	50	85	51,6	19	0,47	M20
UCECH 211	55	2 21/16 21/8 23/16	171	38	106	140	64	95	55,6	22,2	-	M20
UCECH 212	60	2 1/4 25/16 23/8 27/16	194	42	119	140	64	102	65,1	25,4	-	M20

Modalità di caricamento Mode of load	Coefficienti di carico (N) - Load ratings (N)									
Tipo Type	204	205	206	207	208	209	210	211	212	
	14 800	15 500	15 800	16 500	17 300	18 210	18 860	19 800	20 790	
	3 930	4 530	5 100	6 500	7 800	8 710	9 750	10 240	10 750	
	8 500	10 350	10 900	11 300	12 150	12 900	13 550	14 230	14 940	
	40 770	45 300	46 100	44 100	42 800	44 230	44 880	47 120	49 470	

Caratteristiche

- Materiale: PBT (disponibili in color bianco, nero e verde)
- Intercambiabile con supporti in ghisa
- Ingrassatori d'acciaio inox aisi 304
- Temperatura d'esercizio: da -35°C a +102°C
- Coperchio d'estremità
- Guarnizioni interne
- Resistenza chimica (pag. 150)

Characteristics

- Material: PBT (white, black and green colours available)
- Interchangeable with cast iron housing
- Stainless steel aisi 304 greasers
- Working temperature: from -35°C to +102°C
- End cover
- Back seals
- Chemical resistance (pag. 150)

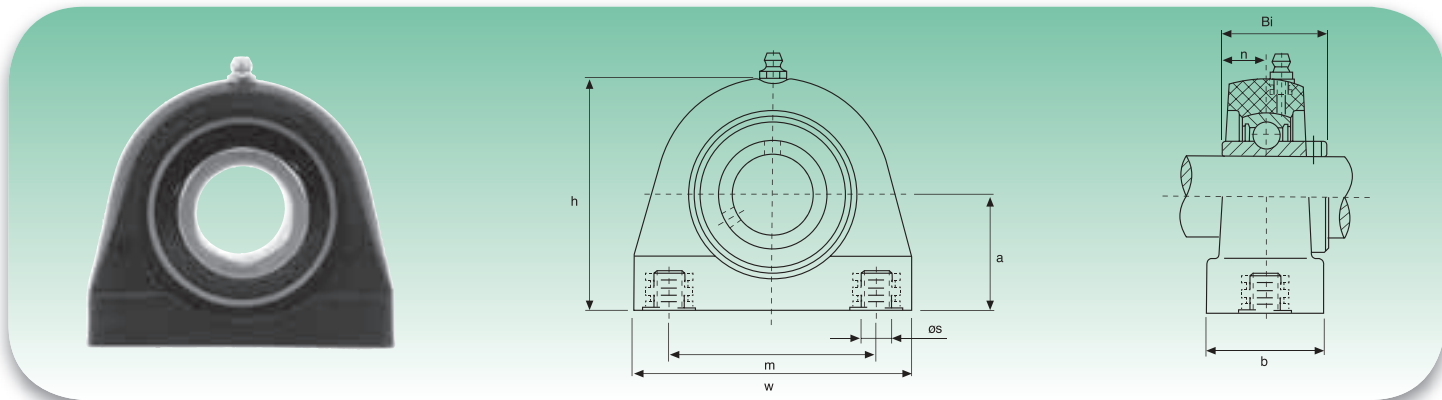
UCPA

Tipo Type	Diametro albero Shaft diameter		Dimensioni - Dimensions							Peso Weight	Bull. fiss. Bolt Size	Coppia (Nm) Torque (Nm)
			a	b	h	m	w	Bi	n			
	mm	inch	mm							kg	S	
UCPA 201	12	½	33,3	34,5	66	50,8	72,8	31	12,7	0,085	M8	18
UCPA 202	15	9/16 5/8	33,3	34,5	66	50,8	72,8	31	12,7	0,085	M8	18
UCPA 203	17	11/16	33,3	34,5	66	50,8	72,8	31	12,7	0,085	M8	18
UCPA 204	20	¾	33,3	34,5	66	50,8	72,8	31	12,7	0,085	M8	18
UCPA 205	25	13/16 7/8 15/16 1	36,5	39,5	73,5	50,8	76,2	34,1	14,3	0,115	M10	25
UCPA 206	30	11/16 11/8 13/16 1¼	42,9	42	84	76,2	101	38,1	15,9	0,17	M10	30
UCPA 207	35	1¼ 15/16 13/8 17/16	47,6	47	95	82,6	110,5	42,9	17,5	0,25	M10	35
UCPA 208	40	1½ 19/16	49,2	48	100,5	88,9	120	49,2	19	0,29	M12	45
UCPA 209	45	15/8 111/16 1¾	54	49,5	108,5	95,3	124	49,2	19	0,34	M12	50
UCPA 210	50	113/16 17/8 115/16 2	57,2	53	115	101,6	136,5	51,6	19	0,43	M16	55
UCPA 211	55	2 21/16 21/8 23/16	140	66	63,5		125	55,6	22,2	1,43	M20	60
UCPA 212	60	2¼ 25/16 25/8 27/16	150	68	69,9		138	65,1	25,4	1,58	M20	65

Modalità di caricamento Mode of load	Coefficients di carico (N) - Load ratings (N)									
Tipo Type	204	205	206	207	208	209	210	211	212	
	8 210	8 540	10 370	12 150	12 230	12 900	13 850	14 540	15 270	
	6 900	7 010	6 580	8 080	9 100	10 400	11 050	11 600	12 180	
	2 980	2 850	4 950	8 160	9 800	10 710	11 360	11 930	12 530	

Caratteristiche

- Materiale: PBT (**disponibili in color bianco, nero e verde**)
- Intercambiabile con supporti in ghisa
- Ingrassatori d'acciaio inox aisi 304
- Temperatura d'esercizio: da -35°C a +102°C
- Coperchio d'estremità
- Guarnizioni interne
- Resistenza chimica (pag. 150)

Characteristics

- Material: PBT (**white, black and green colours available**)
- Interchangeable with cast iron housing
- Stainless steel aisi 304 greasers
- Working temperature: from -35°C to +102°C
- End cover
- Back seals
- Chemical resistance (pag. 150)

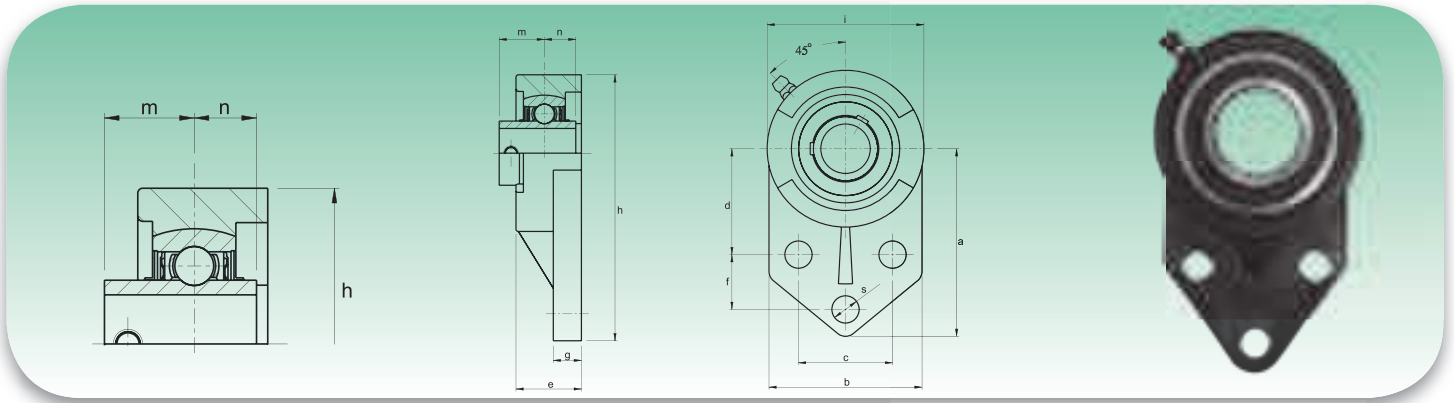

Tipo Type	Diametro albero Shaft diameter		Dimensioni - Dimensions											Peso Weight kg	Bull. fiss. Bolt Size	Coppia Torque (Nm)	
			a	b	c	d	e	f	g	h	i	s	m				n
	mm	inch	mm														
UCFB 201	12	1/2	76	62	38,1	42,9	26,5	22,2	11,4	108	63,5	11	18,3	12,7	0,08	M10	18
UCFB 202	15	9/16 5/8	76	62	38,1	42,9	26,5	22,2	11,4	108	63,5	11	18,3	12,7	0,08	M10	18
UCFB 203	17	11/16	76	62	38,1	42,9	26,5	22,2	11,4	108	63,5	11	18,3	12,7	0,08	M10	18
UCFB 204	20	3/4	76	62	38,1	42,9	26,5	22,2	11,4	108	63,5	11	18,3	12,7	0,08	M10	18
UCFB 205	25	13/16 7/8 15/16 1	85,7	63,5	41,3	46	28	28,6	11,4	121	70	11	19,7	14,3	0,11	M10	25
UCFB 206	30	11/16 11/8 13/16 1 1/4	95	76	47,6	52,4	32	31,8	13	138,5	83	11	22,2	15,9	0,16	M10	30
UCFB 207	35	1 1/4 15/16 13/8 17/16	108	89	50,8	60,3	36,5	31,8	16	157	95	13	25,4	17,5	0,23	M12	35
UCFB 208	40	1 1/2 19/16	114	77	50	60,3	35	41,3	16	163	100	13	30,2	19	0,30	M12	40
UCFB 209	45	1 5/8 1 11/16 1 1/4	121	80	54	65	35	43	18	174	106	17	30,2	19	0,34	M12	45
UCFB 210	50	1 13/16 1 7/8 1 15/16 2	128	86	58	68	35	46	18	184	112	17	32,6	19	0,40	M12	50
UCFB 211	55	2 21/16 21/8 23/16	-	90	62	78	43	50	18	207	130	16	33,4	22,2	-	M14	55
UCFB 212	60	2 1/4 25/16 25/8 27/16	-	94	66	84	48	55	18	223	140	16	39,7	25,4	-	M14	60

Modalità di caricamento Mode of load	Coefficienti di carico (N) - Load ratings (N)									
Tipo Type	201	202	203	204	205	206	207	211	212	
	-	-	-	7 200	9 100	12 200	12 900	13 540	14 200	
	-	-	-	9 200	11 100	11 800	11 900	12 500	13 120	
	-	-	-	2 600	2 800	2 900	3 100	3 250	3 410	

Caratteristiche

- Materiale: PBT (disponibili in color bianco, nero e verde)
- Intercambiabile con supporti in ghisa
- Ingrassatori d'acciaio inox aisi 304
- Temperatura d'esercizio: da -35°C a +102°C
- Coperchio d'estremità
- Guarnizioni interne
- Resistenza chimica (pag. 150)

Characteristics

- Material: PBT (white, black and green colours available)
- Interchangeable with cast iron housing
- Stainless steel aisi 304 greasers
- Working temperature: from -35°C to +102°C
- End cover
- Back seals
- Chemical resistance (pag. 150)

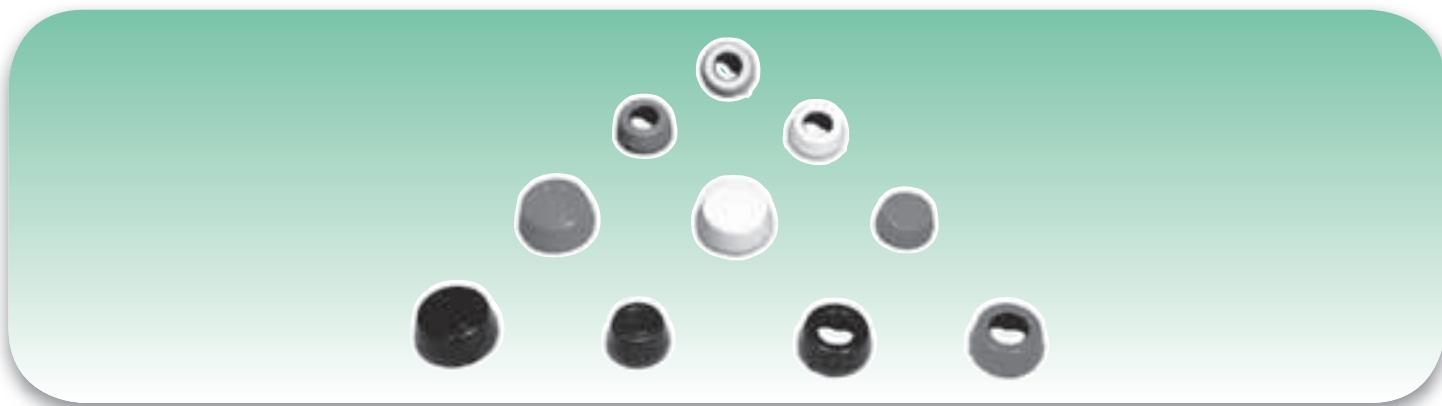
Caratteristiche

- Materiale: Polipropilene (SR 50)
- Approvato FDA
- Coperchio aperto con anello in acciaio inox
- Gamma colori a richiesta

Characteristics

- Material: Polypropylen (SR 50)
- FDA approved
- Open cover with stainless steel ring
- Range of colours on request

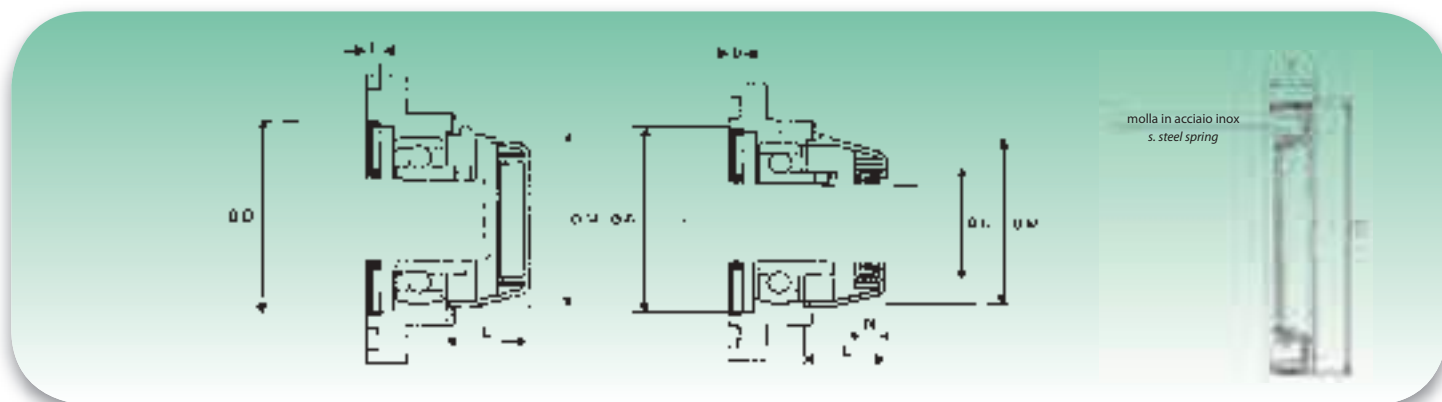

Diametro albero Shaft diameter		Dimensioni - Dimensions					Guarnizione interna - Backseal		
		K	N	L	M	D	b	D	
mm	inch	mm							
12	½	32	7	23	50	52	6	3	52
15	9/16 5/8	32	7	23	50	52	6	3	52
17	11/16	32	7	23	50	52	6	3	52
20	¾	32	7	23	50	52	6	3	52
25	13/16 7/8 15/16 1	37	7	25	55	62	6	3	62
30	11/16 11/8 13/16 1¼	42	7	30	64	72	6	3	72
35	1¼ 15/16 13/8 17/16	47	7	32	74,5	82	6	3	82
40	1½ 19/16	52	7	37	84	88	6	3	88
45	15/8 111/16 1¾	57	7	41	89	93	6	3	93
50	113/16 17/8 115/16 2	62	7	47	94	98	6	3	98
55	2 21/16 21/8 23/16	66	9	56	100	106	6	3	108
60	2¼ 25/16 23/8 27/16	72	9	60	114	116	6	3	117

Con cuscinetto UC non si può montare la tenuta posteriore nei supporti plastici, montaggio fattibile con cuscinetti SB
 With UC bearing don't use the rear seal in the plastic bearing units, feasible assembly only with SB bearings

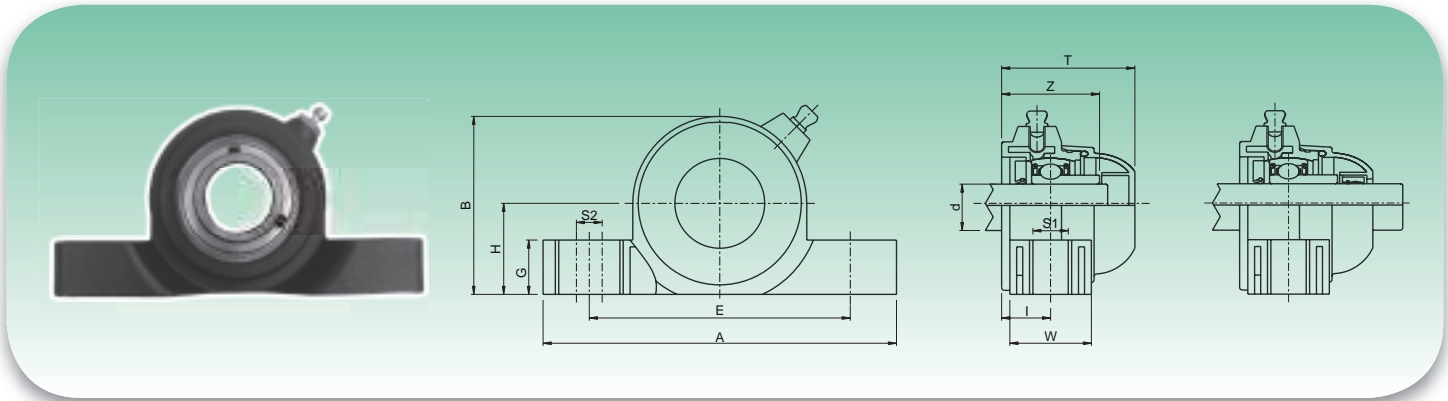

Tipo Type	Diametro albero Shaft diameter	Dimensioni - Dimensions											Carico cuscinetto Bearing load		Carico supporto Bearing units load
		E	A	S1	S2	G	H	B	I	W	Z	T	C (N)	C0 (N)	(N)
		mm													
SBP 204	20	96	130	13	10	20	33,5	65,5	18	30	36	49	12800	6600	5750
SBP 205	25	106	140	13	10	20	36,5	71,5	19,6	35	39	51,7	14000	7800	6900
SBP 206	30	121	163	13	10	20	43	84,5	20,7	36	41,7	55,7	19500	11300	9200
SBP 20	35	126	168	13	10	20	47,6	93,3	22,7	39	48	61,8	25500	15300	11500

Caratteristiche

- Corpo esterno supporto in poliammide rinforzata con fibre di vetro
- Guarnizioni anteriori e posteriori a tenuta stagna NBR per alberi rotanti
- Distanziale di rinforzo fissaggi in acciaio inox AISI 304
- Guarnizione OR in gomma NBR
- Ingrassatore per la rilubrificazione in ottone nichelato
- Grani di bloccaggio con sfera per una maggiore tenuta
- Fori di fissaggio intercambiabili con serie leggera

Characteristics

- Bearing unit body made out of polyamide reinforced with glass fibers
- Front and back seals made out of NBR rubber for turning shaft seal
- Spacer for fixing reinforcement made out of stainless steel AISI 304
- OR seals made out of NBR rubber
- Greaser for relubrication made out of nickel-plated brass
- Setscrews with ball for a perfect endurance
- Interchangeable fixing holes with light series

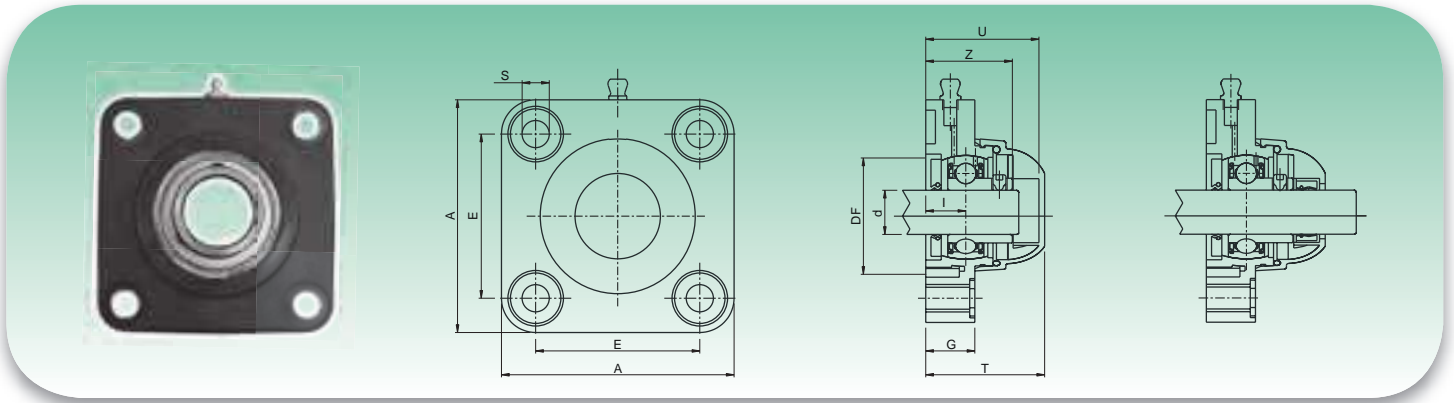

Tipo Type	Diametro albero Shaft diameter	Dimensioni - Dimensions										Carico cuscinetto Bearing load		Carico supporto Bearing units load
		E	A	S	G	I	Z	U	T	DF		C (N)	CO (N)	(N)
		mm										min	max	
SBF 204	20	63,5	90	10,5	19	15,5	33,5	44	46,5	40	45	12800	6600	16500
SBF 205	25	70	99	10,5	22	17	36	47	49	45	50	14000	7800	17000
SBF 206	30	83	113	10,5	26	20	41	54	56	50	60	19500	11300	17500
SBF 207	35	92	122	10,5	26	20	45	57	59	55	70	25500	15300	18000
SBF 208	40	102	133	10,5	26	19,5	48,5	65	68	78	65	32500	19800	18000

Caratteristiche

- Corpo esterno supporto in poliammide rinforzata con fibre di vetro
- Guarnizioni anteriori e posteriori a tenuta stagna NBR per alberi rotanti
- Distanziale di rinforzo fissaggi in acciaio inox AISI 304
- Guarnizione OR in gomma NBR
- Ingrassatore per la rilubrificazione in ottone nichelato
- Grani di bloccaggio con sfera per una maggiore tenuta
- Fori di fissaggio intercambiabili con serie leggera

Characteristics

- Bearing unit body made out of polyamide reinforced with glass fibers
- Front and back seals made out of NBR rubber for turning shaft seal
- Spacer for fixing reinforcement made out of stainless steel AISI 304
- OR seals made out of NBR rubber
- Greaser for relubrication made out of nickel-plated brass
- Setscrews with ball for a perfect endurance
- Interchangeable fixing holes with light series

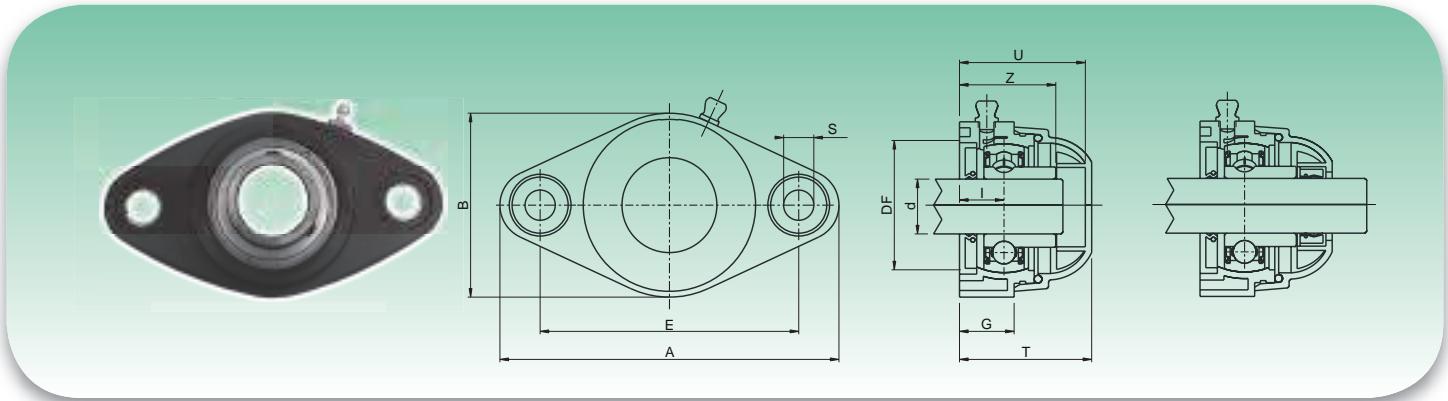

Tipo Type	Diametro albero Shaft diameter	Dimensioni - Dimensions											Carico cuscinetto Bearing load		Carico supporto Bearing units load
		E	A	B	S	G	I	Z	U	T	DF		C (N)	C ₀ (N)	(N)
		mm													
SBFL 204	20	90	118	64	10,5	19	15,5	33,5	44	46,5	40	45	12800	6600	8500
SBFL 205	25	99	131	72	10,5	22	17	36	47	49	45	50	14000	7800	10000
SBFL 206	30	117	149	86	10,5	26	20	41	54	56	50	60	19500	11300	13000
SBFL 207	35	130	163	94	10,5	26	20	45	57	59	55	70	25500	15300	14000
SBFL 208	40	144	172	100	10,5	27	19,5	48,5	65,5	71	65	78	30700	19000	15000

Caratteristiche

- Corpo esterno supporto in poliammide rinforzata con fibre di vetro
- Guarnizioni anteriori e posteriori a tenuta stagna NBR per alberi rotanti
- Distanziale di rinforzo fissaggi in acciaio inox AISI 304
- Guarnizione OR in gomma NBR
- Ingrassatore per la rilubrificazione in ottone nichelato
- Grani di bloccaggio con sfera per una maggiore tenuta
- Fori di fissaggio intercambiabili con serie leggera

Characteristics

- Bearing unit body made out of polyamide reinforced with glass fibers
- Front and back seals made out of NBR rubber for turning shaft seal
- Spacer for fixing reinforcement made out of stainless steel AISI 304
- OR seals made out of NBR rubber
- Greaser for relubrication made out of nickel-plated brass
- Setscrews with ball for a perfect endurance
- Interchangeable fixing holes with light series

**Caratteristiche**

- Coperchio di protezione in polipropilene

Characteristics

- Protection cover made out of polypropylene

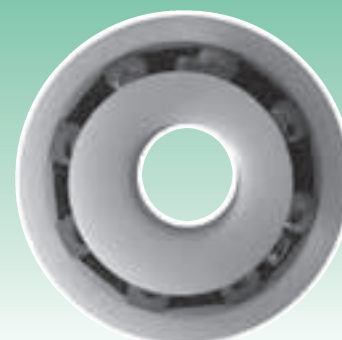
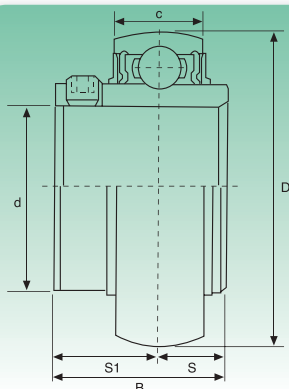

Tipo Type	Dimensioni - Dimensions						Carico Kg. cuscinetto (daN) (Kp) Rating load bearing (daN) (Kp)		Numero di giri max./min. Speed max. r.p.m.	Peso Weight kg
	d	D	B	C	S ₁	S	Dinamico Dynamic	Statico Static		
	mm/inch									
UC 200	10 ¾	47 1,8504	31 1,2205	17 0,6693	18,3 0,720	12,7 0,500	42	27	1050	0,30
UC 201 UC 201-8	12 ½	47 1,8504	31 1,2205	17 0,6693	18,3 0,720	12,7 0,500	42	27	1050	0,30
UC 202 UC 202-9 UC 202-10	15 9/16 5/8	47 1,8504	31 1,2205	17 0,6693	18,3 0,720	12,7 0,500	42	27	1050	0,30
UC 203 UC 203-11	17 11/16	47 1,8504	31 1,2205	17 0,6693	18,3 0,720	12,7 0,500	42	27	1050	0,30
UC 204 UC 204-12	20 ¾	47 1,8504	31 1,2205	17 0,6693	18,3 0,720	12,7 0,500	42	27	1050	0,30
UC 205 UC 205-13 UC 205-14 UC 205-15 UC 205-16	25 13/16 7/8 15/16 1	52 2,0472	34,1 1,3425	17 0,6693	19,8 0,780	14,3 0,563	48	32	950	0,46
UC 206 UC 206-17 UC 206-18 UC 206-19 UC 206-20	30 11/16 11/8 13/16 1¼	62 2,4409	38,1 1,5000	19 0,7480	22,2 0,874	15,9 0,626	55	36	800	0,69
UC 207 UC 207-20 UC 207-21 UC 207-22 UC 207-23	35 1¼ 15/16 13/8 17/16	72 2,8346	42,9 1,6890	20 0,7874	25,4 1,000	17,5 0,689	62	41	700	0,89
UC 208 UC 208-24 UC 208-25	40 1½ 19/16	80 3,1496	49,2 1,9370	22 0,8661	30,2 1,189	19 0,748	66	44	625	1,08

Disponibile anche:

Cuscinetti a sfere in acciaio inox (AISI 440C o 420C)

Cuscinetti a sfere in acciaio (Cromo 100CR6 - SAE 52100)

Per misure e carichi vedere a pagina 102

I cuscinetti sono di tipo aperto nella versione standard, sono anche disponibili con protezione singola e doppia. I valori riportati nella sopra indicata tabella si riferiscono a cuscinetti a sfere con anelli in resina acetalica (POM).

Available also:

Stainless steel bearings (AISI 440C or 420C)

Chrome steel bearings (Chrome 100CR6 - SAE 52100)

For size and load see page 102

In standard version, the bearing are open, but can also be supplied in one or double shield version. The load capacities and speed limits stated in the table above, apply only to ball bearings with ring of polyacetal (POM).

SA

Suffisso UNF: Misure in pollici dei grani di bloccaggio
UNF suffix: inch sizes set screws

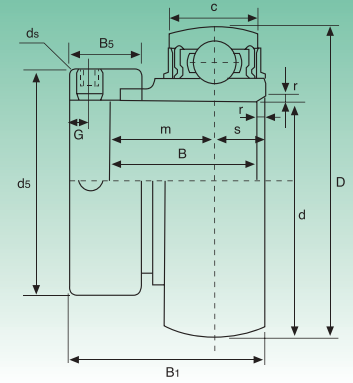

Tipo Type	Dimensioni - Dimensions												Carico Kg. cuscinetto (daN) (Kp) Rating load bearing (daN) (Kp)		Peso Weight kg
	d	c	D	B	r	s	m	B ₁	ds	B _s	G	ds	Dinamico Dynamic	Statico Static	
	mm/inch														
SA 204	20	14	47	21,5	1,5	7	14,5	31	33,3	13,5	5	M6x0,75	60,6	37,8	0,10
SA 204-12	¾	0,5512	1,8504	0,8465	0,0591	0,2756	0,5709	1,2205	1,3110	0,5315	0,1969	-			
SA 205	25	15	52	21,5	1,5	7,5	14	31	38,1	13,5	5	M6x0,75	66	42,6	0,11
SA 205-13	13/16	0,5906	2,0472	0,8465	0,0591	0,2953	0,5512	1,2205	1,5000	0,5315	0,1969	-			
SA 205-14	7/8														
SA 205-15	15/16														
SA 205-16	1														
SA 206	30												16	62	23,8
SA 206-17	11/16	0,6299	2,4409	0,9370	0,0591	0,3150	0,6220	1,4055	1,7520	0,6260	0,2362	5/16 24 UNF			
SA 206-18	11/8														
SA 206-19	13/16														
SA 206-20	1¼														
SA 207	35												17	72	25,4
SA 207-20	1¼	0,6693	2,8346	1,000	0,0787	0,3346	0,6654	1,5315	2,1890	0,6890	0,2560	5/16 24 UNF			
SA 207-21	15/16														
SA 207-22	13/8														
SA 207-23	17/16														
SA 208	40												19	80	30,2
SA 208-24	1½	0,7480	3,1496	1,1890	0,0787	0,3740	0,8346	1,7205	2,3740	0,7205	0,2560	5/16 24 UNF			
SA 208-25	19/16														
SA 209	45												19	85	30,2
SA 209-26	15/8	0,7480	3,3465	1,1890	0,0787	0,3740	0,8150	1,7205	2,5000	0,7205	0,2560	5/16 24 UNF			
SA 209-27	111/16														
SA 209-28	1¾														
SA 210	50												20	90	30,2
SA 210-29	113/16	0,7874	3,5433	1,1890	0,0787	0,3937	0,8346	1,7205	2,7520	0,7205	0,2560	-			
SA 210-30	17/8														
SA 210-31	115/16														
SA 210-32	2														

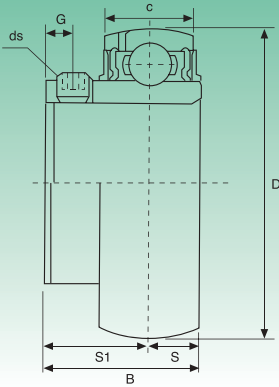

Suffisso UNF: Misure in pollici dei grani di bloccaggio
UNF suffix: inch sizes set screws

Tipo Type	Dimensioni - Dimensions								Carico Kg. cuscinetto (daN) (Kp) Rating load bearing (daN) (Kp)		Peso Weight kg
	d	c	D	B	s	S ₁	G	ds	Dinamico Dynamic	Statico Static	
	mm/inch										
SB 204	20	14	47	25	7	18	4,5	M6x0,75	60,6	37,8	0,08
SB 204-12	¾	0,5512	1,8504	0,9843	0,2756	0,7087	0,1772	-			
SB 205	25	15	52	27	7,5	19,5	5	M6x0,75	66	42,6	0,10
SB 205-13	13/16	0,5906	2,0472	1,0630	0,2953	0,7677	0,1969	-			
SB 205-14	7/8										
SB 205-15	15/16										
SB 205-16	1										
SB 206	30								16	62	30
SB 206-17	11/16	0,6299	2,4409	1,1811	0,3150	0,8661	0,2165	-			
SB 206-18	11/8										
SB 206-19	13/16										
SB 206-20	1¼										
SB 207	35								17	72	32
SB 207-20	1¼	0,6693	2,8346	1,2598	0,3346	0,9252	0,2362	5/16 24 UNF			
SB 207-21	15/16										
SB 207-22	13/8										
SB 207-23	17/16										
SB 208	40								19	80	34
SB 208-24	1½	0,7480	3,1496	1,3386	0,3740	0,9843	0,3150	5/16 24 UNF			
SB 208-25	19/16										
SB 209	45	19	85	41,2	10,2	31	8	M8x1	154,2	108,6	0,48
SB 209-26	15/8	0,7480	3,3465	1,6220	0,4016	1,2205	0,3150	5/16 24 UNF			
SB 209-27	111/16										
SB 209-28	1¾										
SB 210	50								20	90	43,5
SB 210-29	113/16	0,7874	3,5433	1,7126	0,4291	1,2835	0,3543	-			
SB 210-30	17/8										
SB 210-31	115/16										
SB 210-32	2										

Proprietà tipiche del PBT
Typical properties of PBT

Proprietà meccaniche <i>Mechanicals properties</i>	Unità <i>Unit</i>	Metodo per il test <i>Method test</i>	Valori <i>Value</i>
Resistenza alla trazione prima della deformazione prima della rottura <i>Tensile strenght at yield at break</i>	N/mm ² N/mm ²	ASTM D 638 ASTM D 638	115 -
<i>Tensile strenght at yield at break</i>	N/mm ² N/mm ²	ASTM D 638 ASTM D 638	115 -
Allungamento relativo prima della deformazione prima della rottura <i>Elongation at yield at break</i>	% %	ASTM D 638 ASTM D 638	3 -
<i>Elongation at yield at break</i>	% %	ASTM D 638 ASTM D 638	3 -
Modulo elastico a trazione <i>Tensile modulus</i>	N/mm ² N/mm ²	ASTM D 638 ASTM D 638	8000 8000
Resistenza alla flessione prima della deformazione <i>Flexural yield strenght</i>	N/mm ² N/mm ²	ASTM D 790 ASTM D 790	170 170
Modulo di rigidità flessionale <i>Flexural modulus</i>	N/mm ² N/mm ²	ASTM D 790 ASTM D 790	7000 7000
Resistenza all'impatto ad intaglio Charpy <i>Notched impact strenght Charpy</i>	K/m ² K/m ²	DIN 53453 DIN 53453	12 12
Resistenza all'impatto ad intaglio IZOD <i>Notched impact strenght IZOD</i>	N/mm ² N/mm ²	ASTM D 256 ASTM D 256	100 100
Durezza <i>Hardness</i> H358/10 H358/60 Rockwell	N/mm ² N/mm ² N/mm ²	DIN 53456 DIN 53456 ASTM D 785	140 101 L102

Proprietà termiche <i>Thermal properties</i>	Unità <i>Unit</i>	Metodo per il test <i>Method test</i>	Valori <i>Value</i>
Coefficiente di ossigeno <i>Oxygen index</i>	% %	ASTM D 2863 ASTM D 2863	19 19
Ritardamento di fiamma (1/6 mm spessore) <i>Flame retardancy (1/6 mm trickness)</i>	- -	UL stand 94 UL stand 94	94HB 94HB
Resistenza al calore: Vicat, Metodo B <i>Heat resistance: Vicat, Method B</i>	°C °C	ASTM D 1525 ASTM D 1525	210-215 210-215
Conduttività termica <i>Thermal conductivity</i>	W/m ² C W/m ² C	ASTM C 177 ASTM C 177	0,19 0,19
Flusso di contrazione dello stampo <i>Modul shrinkage flow</i>	% %	ASTM D 1299 ASTM D 1299	0,4-0,6 0,4-0,6
Direzione di flusso trasversale <i>Cross flow direction</i>	% %	ASTM D 1299 ASTM D 1299	0,6-0,8 0,6-0,8

Proprietà fisiche <i>Physicals properties</i>	Unità <i>Unit</i>	Metodo per il test <i>Method test</i>	Valori <i>Value</i>
Assorbimento dell'acqua <i>Water absorption</i> 24 ore, 23°C 24 Hrs, 23°C	%	ASTM D 570	0,06

Resistenza chimica del PBT
Chemical resistance of PBT

Acidi <i>Acids</i>	°C	% giorni immulsione <i>% Immulsion days</i>	% Forza di ritenzione <i>% Strenght of ritenion</i>
10% Cloridrico <i>10% Hydrochloric</i>	23	30	89
	23	90	85
	23	180	82
10% Solforico <i>10% Sulfuric</i>	23	30	97
	23	90	94
	23	180	90
36% Solforico (batteria) <i>36% Sulfuric (battery)</i>	23	30	89
	23	30	97
	23	180	96
	66	30	84
	66	180	35
10% Acetico <i>10% Acetic</i>	23	30	89
	23	180	88

Basi <i>Bases</i>	°C	% giorni immulsione <i>% Immulsion days</i>	% Forza di ritenzione <i>% Strenght of ritenion</i>
5% Idrossido di potassio <i>5% Potassium Hydroxide</i>	23	30	83
	23	90	10
10% Idrossido di sodio <i>10% Sodium Hydroxide</i>	23	30	2
	23	180	-
10% Idrossido di Ammonio <i>10% Ammonium Hydroxide</i>	23	30	90
	23	90	87
	23	180	58

Solventi organici <i>Organic Solvents</i>	°C	% giorni immulsione <i>% Immulsion days</i>	% Forza di ritenzione <i>% Strenght of ritenion</i>
Alcol etilico <i>Ethyl Alcohol</i>	23	30	99
	23	180	94
Alcol metilico <i>Methyl Alcohol</i>	23	30	91
	23	180	76
Alcol isopropilico <i>Isopropyl-Alcohol</i>	23	30	100
	23	180	100
Alcol isopropilico e acqua (50:50) <i>Isopropyl-Alcohol & Water (50:50)</i>	23	30	93
	23	180	96
Acquaragia <i>Turpentine</i>	23	180	92
	23	30	66
Acetone <i>Acetonz</i>	23	180	63
	23	30	90



Tabella - Diametri foro del cuscinetto
 Table - Hole bearing diameters

Dimensioni Dimensions	Tipologia supporto Support type		Cuscinetto Bearing	Carico assiale dinamico (kN) Axial dynamic load (kN)	Carico radiale dinamico (kN) Radial dynamil load (kN)
Ø 6	ad incastro <i>fixed</i>	FK 6	706 DFA	-	-
		EK 6			
	ad appoggio <i>supported</i>	EF 6	606 ZZ	-	2,31
		EF 8			
Ø 8	ad incastro <i>fixed</i>	FK 8	708 DFA	-	-
		EK 8			
	ad appoggio <i>supported</i>	FF 10	608 ZZ	-	3,35
		BF 10			
Ø 10	ad incastro <i>fixed</i>	FK 10	7000 DFA	6,7	2,78
		BK 10			
	ad appoggio <i>supported</i>	FF 12	6000 ZZ	-	4,65
		BF 12			
Ø 12	ad incastro <i>fixed</i>	FK 12	7001 DFA	7,25	3,1
		BK 12			
	ad appoggio <i>supported</i>	-	-	-	-
Ø 15	ad incastro <i>fixed</i>	FK 15	7003 DFA	7,75	4,07
		BK 15			
	ad appoggio <i>supported</i>	FF 15	6002 ZZ	-	5,7
		BF 15			
Ø 17	ad incastro <i>fixed</i>	BK 17	7206 DFA	14	5,95
	ad appoggio <i>supported</i>	BF 17	6203 ZZ	-	9,75
Ø 20	ad incastro <i>fixed</i>	FK 20	7204 DFA	18,3	9,7
		BK 20			
	ad appoggio <i>supported</i>	FF 20	6204 ZZ	-	13
		BF 20	6004 ZZ	-	9,55
Ø 25	ad incastro <i>fixed</i>	FK 25	7205 DFA	20,6	11,7
		BK 25			
	ad appoggio <i>supported</i>	FF 25	6205 ZZ	-	14,3
		BF 25			
Ø 30	ad incastro <i>fixed</i>	FK 30	7206 DFA	28,6	16,6
		BK 30			
	ad appoggio <i>supported</i>	FF 30	6206 ZZ	-	19,8
		BF 30			
Ø 35	ad incastro <i>fixed</i>	BK 35	7207 DFA	-	-
	ad appoggio <i>supported</i>	BF 35	6207 ZZ	-	25,5
Ø 40	ad incastro <i>fixed</i>	BK 40	7208 DFA	45	27,7
	ad appoggio <i>supported</i>	BF 40	6208 ZZ	-	29,7

NOTA:
 I supporti a incastro EK montano gli stessi cuscinetti dei supporti FK della medesima dimensione.
 I supporti ad appoggio EF montano gli stessi cuscinetti dei supporti ad appoggio FF della medesima dimensione.

NOTE:
 In the fixed supports EK there are the same bearings of the same size of fixed supports FK.
 In the floated supports EF there are the same bearings of the same size of floated supports FF.

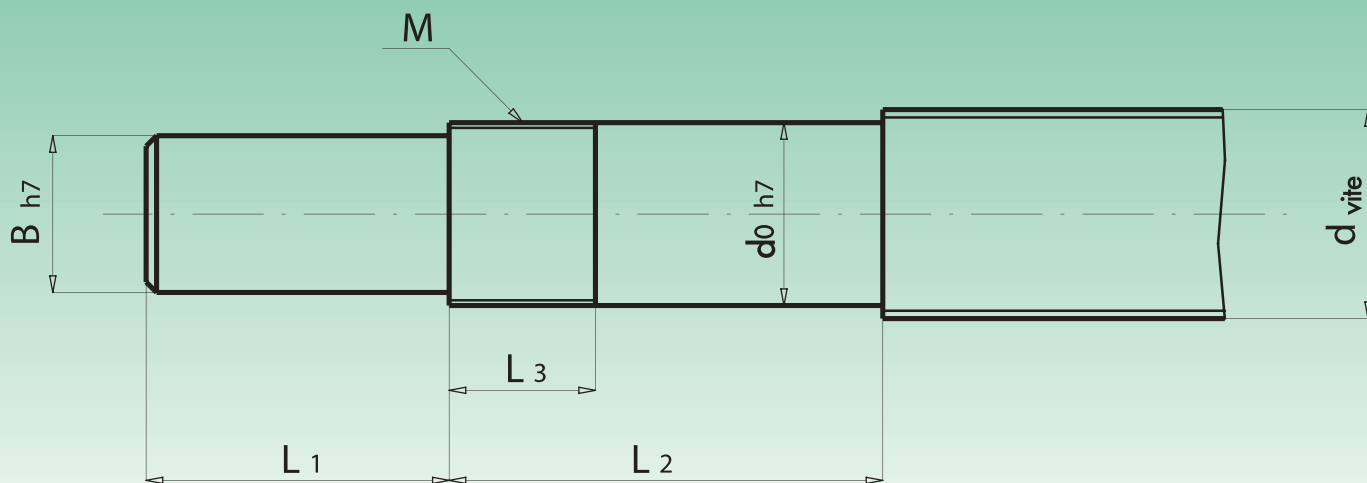

Per supporti di tipologia ad incastro FK, BK e EK.
For fixed-side support unit types FK, BK and EK.

Codoli raccomandati - Recommended shaft and shape

Tipo Type	Dimensioni - Dimensions						
	d ₀	d _{vite}	B	L ₁	L ₂	M	L ₃
	mm						
FK 5	5	6	4	6	20	M 5x0.75	7
FK 6	6	8	4	8	24	M 6x0.75	8
FK 8	8	10	6	10	32	M 8x1	10
FK 10	10	12/14	8	15	39	M 10x1	12
FK 12	12	14/16	10	15	39	M 12x1	12
FK 15	15	20	12	20	41	M 15x1	12
FK 20	20	25/32	17	27	59	M 20x1	14
FK 25	25	32	20	36	68	M 25x1.5	18
FK 30	30	40	25	42	72	M 30x1.5	24
BK 10	10	12/14	8	15	39	M 10x1	12
BK 12	12	14/16	10	15	39	M 12x1	12
BK 15	15	20	12	20	41	M 15x1	12
BK 17	17	20/25	15	27	53	M 17x1	14
BK 20	20	25/32	17	27	53	M 20x1	14
BK 25	25	32	20	36	65	M 25x1.5	18
BK 30	30	40	25	42	72	M 30x1.5	24
BK 35	35	40	30	58	83	M 35x1.5	28
BK 40	40	50	35	70	98	M 40x1.5	35
EK 5	5	6	4	6	20	M 5x0.75	7
EK 6	6	8	4	8	24	M 6x0.75	8
EK 8	8	10	6	10	32	M 8x1	10
EK 10	10	12/14	8	15	39	M 10x1	12
EK 12	12	14/16	10	15	39	M 12x1	12
EK 15	15	20	12	20	41	M 15x1	12
EK 20	20	25/32	17	27	59	M 20x1	14

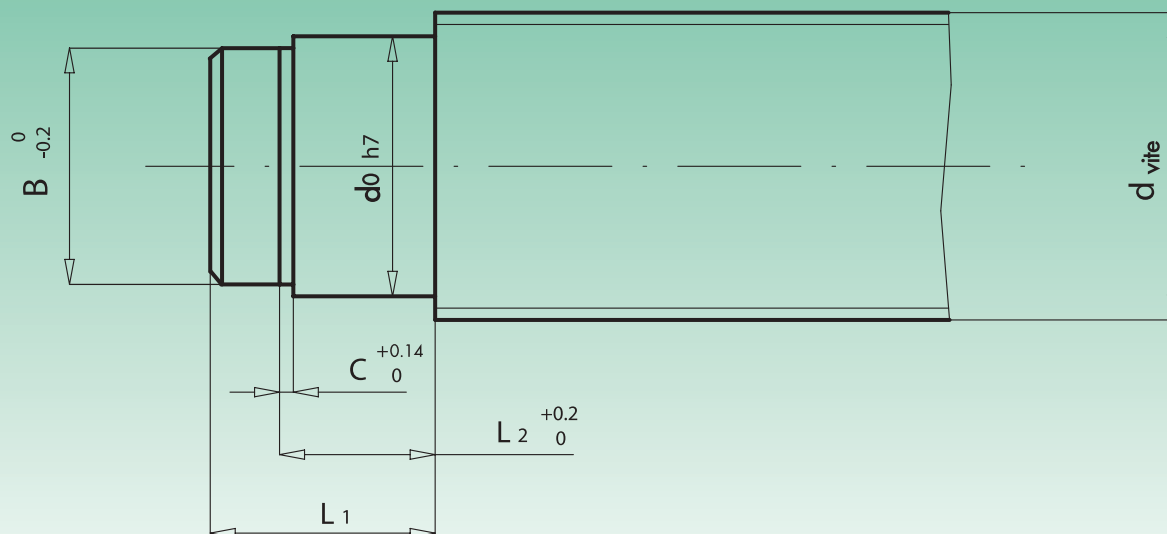

Per supporti di tipologia ad appoggio FF, BF e EF.
For floated-side support unit types FF, BF and EF.

Codoli raccomandati - Recommended shaft and shape

Tipo Type	Dimensioni - Dimensions					
	d ₀	d _{vite}	B	C	L ₁	L ₂
mm						
FF 10	8	10/12	7,6	0,9	11	7,9
FF 12	10	16	9,6	1,15	12	9,15
FF 15	15	20	14,3	1,15	12	10,15
FF 20	20	25/32	19	1,35	18	15,35
FF 25	25	32	23,9	1,35	20	16,35
FF 30	30	40	28,6	1,75	20	17,75
BF 10	8	10/12	7,6	0,9	11	7,9
BF 12	10	16	9,6	1,15	12	9,15
BF 15	15	20	14,3	1,15	12	10,15
BF 17	17	20/25	16,2	1,15	16	13,15
BF 20	20	25/32	19	1,35	16	13,35
BF 25	25	32	23,9	1,35	20	16,35
BF 30	30	40	28,6	1,75	20	17,75
BF 35	35	40	33	1,75	25	19,75
BF 40	40	50	38	1,75	25	19,75
EF 6	6	8	5,6	0,8	9	7,0
EF 8	6	8	5,6	0,9	10	7,0
EF 10	8	10/12	7,6	0,9	11	7,9
EF 12	10	16	9,6	1,15	12	9,15
EF 15	15	20	14,3	1,15	12	10,15
EF 20	20	25/32	19	1,35	18	15,35

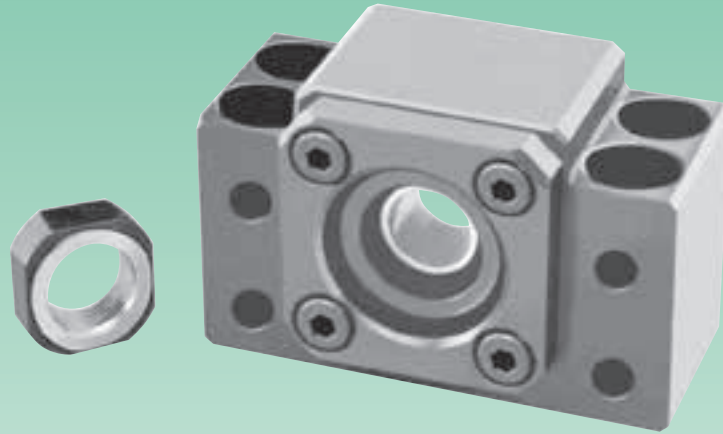
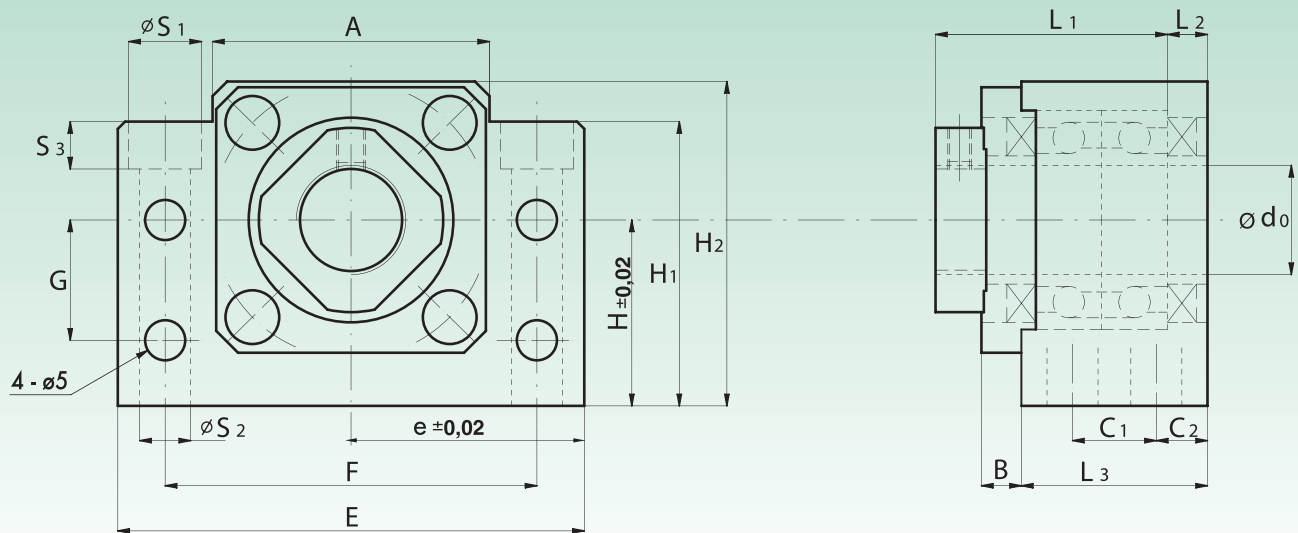
Supporti di tipologia ad incastro BK, FK e EK
Fixed-side support unit types BK, FK and EK

Ghiera inclusa
Lock nut included

Tipo Type	Dimensioni - Dimensions																			
	d_0	L_1	L_2	L_3	$H \pm 0,02$	H_1	H_2	A	B	C_1	C_2	E	$e \pm 0,02$	F	G	s	S_1	S_2	S_3	
mm																				
BK 10	10	31	7	25	22	32,5	39	34	6	13	6	60	30	46	15	5,5	11	6,6	5	
BK 12	12	31	7	25	25	35	43	35	6	13	6	60	30	46	18	5,5	11	6,6	6,5	
BK 15	15	33	7	27	28	38	48	40	6	15	6	70	35	54	18	5,5	11	6,6	6,5	
BK 17	17	43	9	35	39	55	64	50	8	19	8	86	43	68	28	6,6	14	9	8,5	
BK 20	20	43	9	35	34	50	60	52	8	19	8	88	44	70	22	6,6	14	9	8,5	
BK 25	25	52	10	42	48	70	80	64	12	22	10	106	53	85	33	9	17,5	11	11	
BK 30	30	55	11	45	51	78	89	76	14	23	11	128	64	102	33	11	20	14	13	
BK 35	35	63	12	50	52	79	96	88	14	26	12	140	70	114	35	11	20	14	13	
BK 40	40	71	16	61	60	90	110	100	18	33	14	160	80	130	37	14	26	18	17,5	

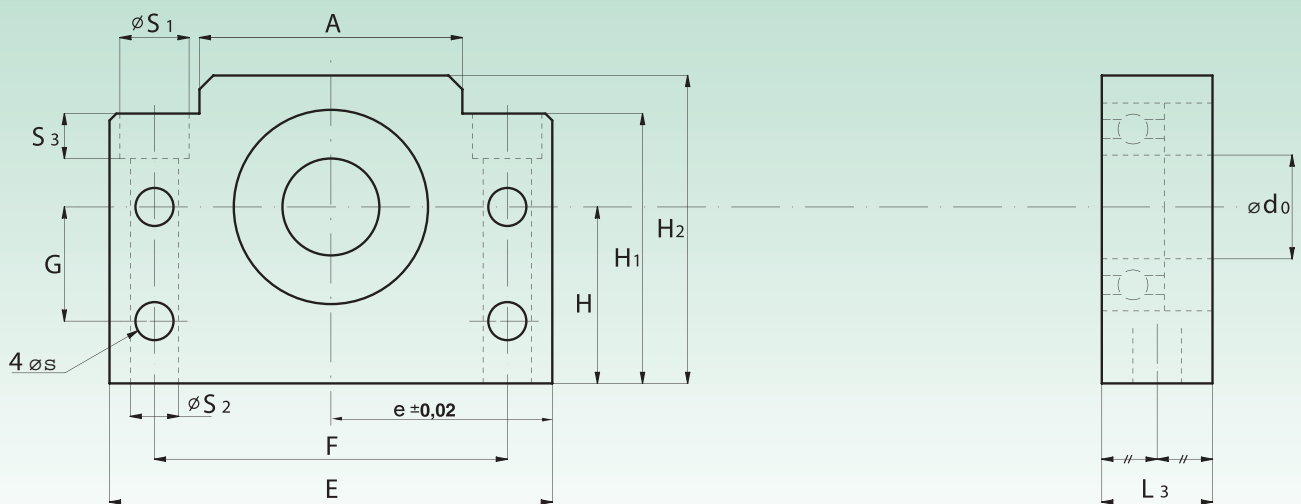
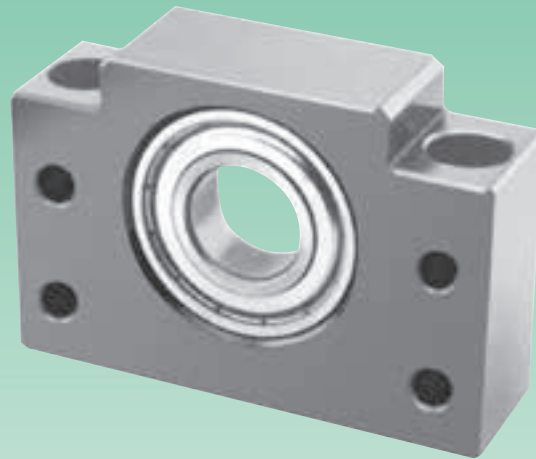
Supporti di tipologia ad appoggio BF, FF e EF
Floated-side support unit types BF, FF and EF

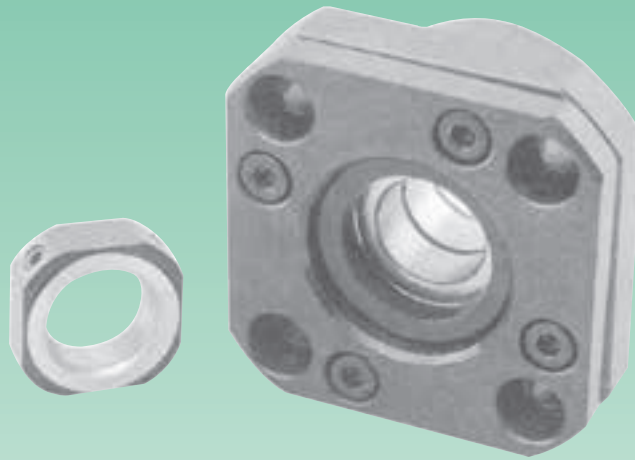
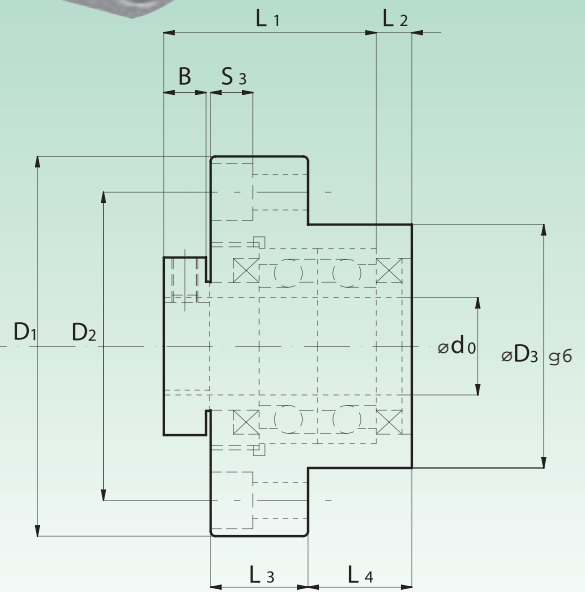
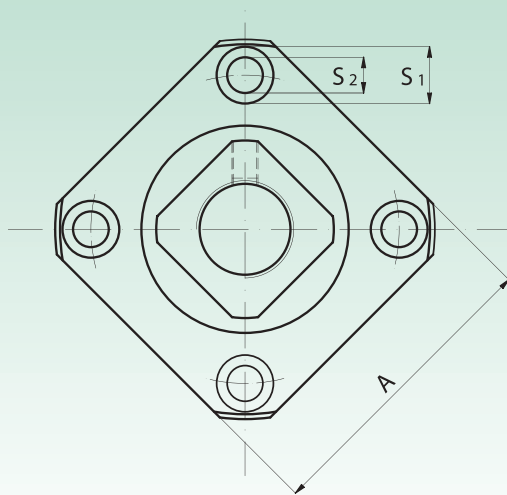

Tipo Type	Dimensioni - Dimensions													
	d_0	L_3	$H^{\pm 0,02}$	H_1	H_2	A	E	$e^{\pm 0,02}$	F	G	s	S_1	S_2	S_3
mm														
BF 10	8	20	22	32,5	39	34	60	30	46	15	5,5	11	6,6	5
BF 12	10	20	25	35	43	35	60	30	46	18	5,5	11	6,6	6,5
BF 15	15	20	28	38	48	40	70	35	54	18	5,5	11	6,6	6,5
BF 17	17	23	39	55	64	50	86	43	68	28	6,6	14	9	8,5
BF 20	20	26	34	50	60	52	88	44	70	22	6,6	14	9	8,5
BF 25	25	30	48	70	80	64	106	53	85	33	9	17,5	11	11
BF 30	30	32	51	78	89	76	128	64	102	33	11	20	14	13
BF 35	35	32	52	79	96	88	140	70	114	35	11	20	14	13
BF 40	40	37	60	90	110	100	160	80	130	37	14	26	18	17,5

Supporti di tipologia ad incastro FK, BK e EK
Fixed-side support unit types FK, BK and EK

Ghiera inclusa
Lock nut included

Tipo Type	Dimensioni - Dimensions												
	d ₀	D ₁	D ₂	D ₃	L ₁	L ₂	L ₃	L ₄	A	B	S ₁	S ₂	S ₃
mm													
FK 5	5	34	26	20	18,5	3,5	6	10,5	26	5	6,5	3,4	4
FK 6	6	36	28	22	22	3,5	7	13	28	5	6,5	3,4	4
FK 8	8	43	35	26	26	4	9	14	35	6,5	6,5	3,4	4
FK 10	10	52	42	34	29	5	11	17	42	8	8	4,5	5
FK 12	12	54	44	36	29,5	5	11	17	44	8	8	4,5	5
FK 15	15	63	50	40	33	6	15	17	52	8	9,5	5,5	6
FK 20	20	85	70	57	48	10	22	30	68	10	11	6,6	10
FK 25	25	98	80	63	57	10	27	30	79	10	14	9	11
FK 30	30	117	95	75	60	11	30	32	93	12	17,5	11	13

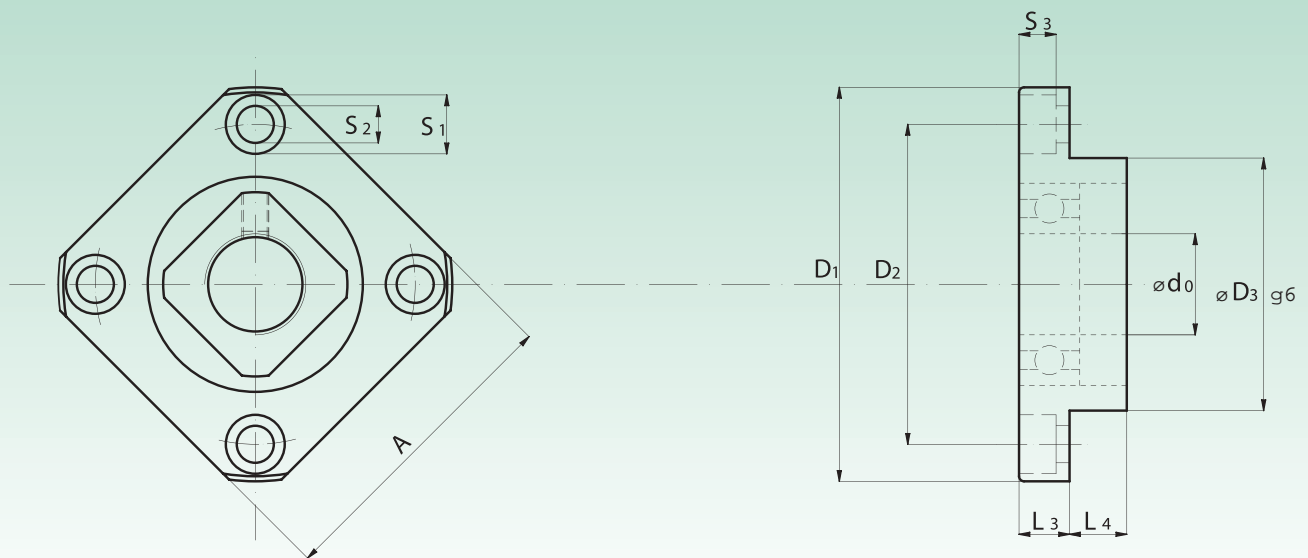
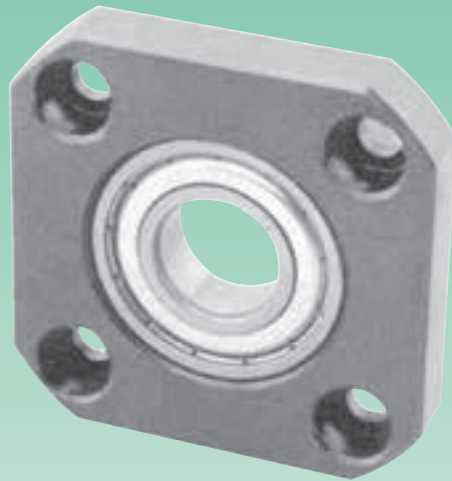
Supporti di tipologia ad appoggio FF, BF e EF
Floated-side support unit types FF, BF and EF

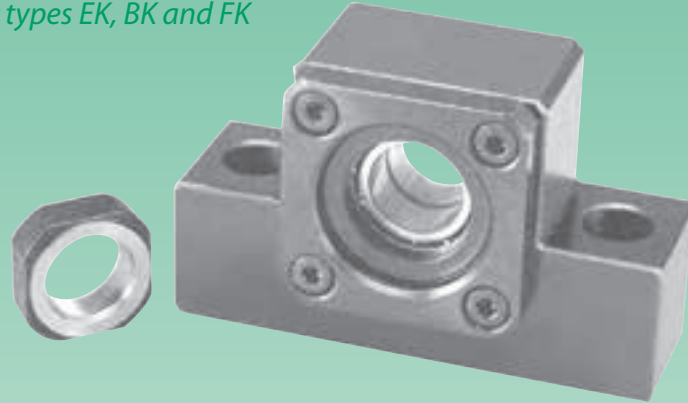
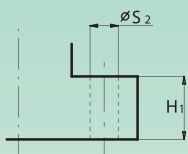
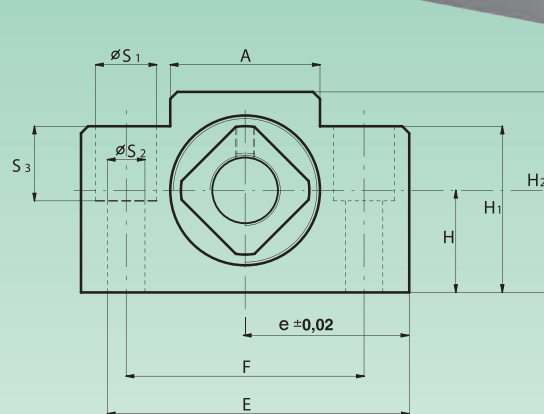
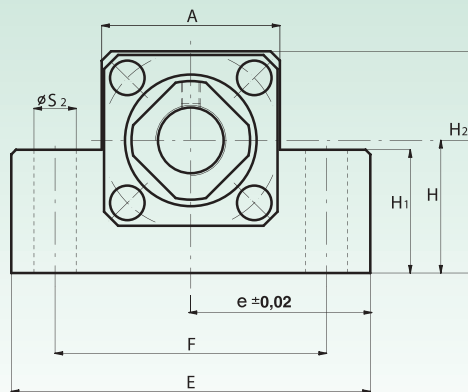
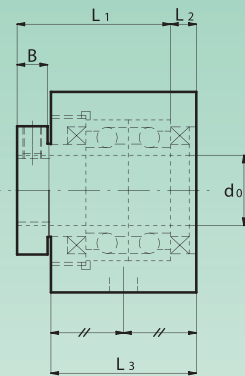
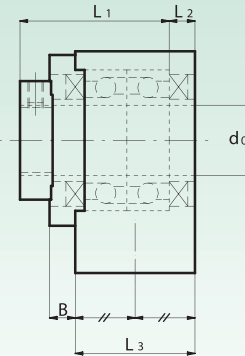

Tipo Type	Dimensioni - Dimensions									
	d_0	D_1	D_2	D_3	L_3	L_4	A	S_1	S_2	S_3
	mm									
FF 10	8	43	35	28	7	5	35	6,5	3,4	4
FF 12	10	52	42	34	7	8	42	8	4,5	4
FF 15	15	63	50	40	9	8	52	9,5	5,5	6
FF 20	20	85	70	57	11	9	68	11	6,6	6,5
FF 25	25	98	80	63	14	10	79	14	9	9
FF 30	30	117	95	75	18	17	93	17,5	11	11

Supporti di tipologia ad incastro EK, BK e FK
Fixed-side support unit types EK, BK and FK

Ghiera inclusa
Lock nut included

EK 5

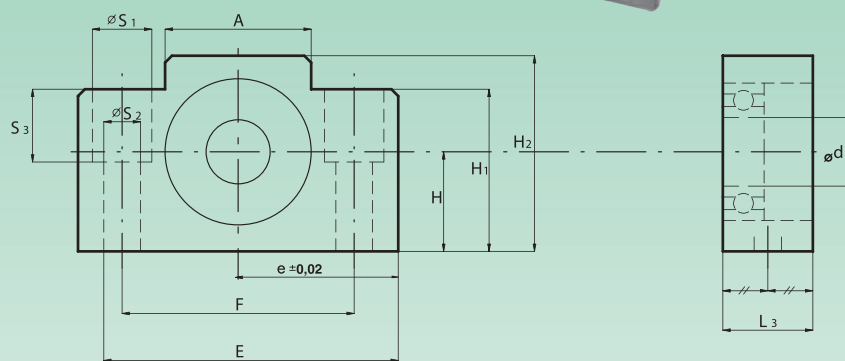
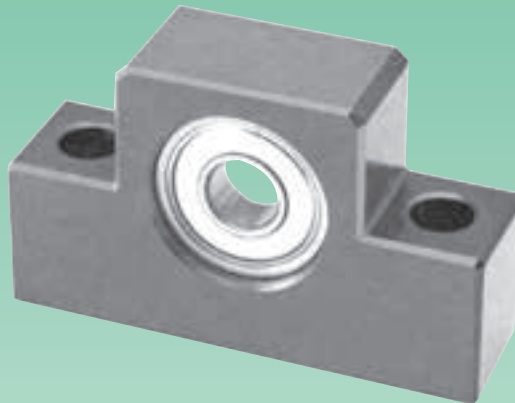
EK 6-8

EK 10 - 20

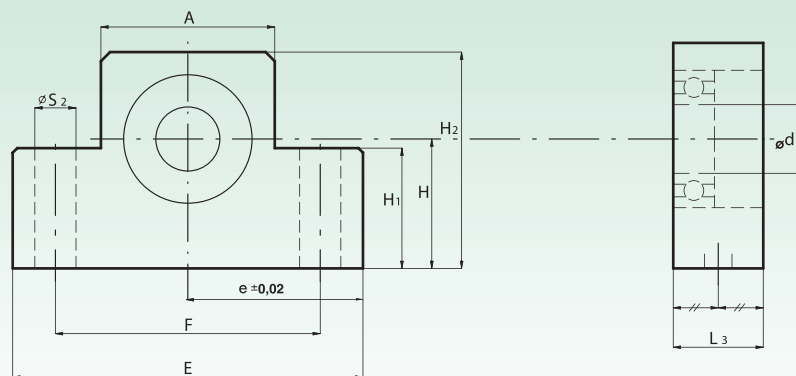
Tipo Type	Dimensioni - Dimensions														
	d ₀	L ₁	L ₂	L ₃	H ^{±0,02}	H ₁	H ₂	A	B	E	e ^{±0,02}	F	S ₁	S ₂	S ₃
mm															
EK 5	5	18,5	3,5	16,5	11	8	21	20	5	36	18	28	-	4,5	-
EK 6	6	22	3,5	20	13	20	25	18	5	42	21	30	9,5	5,5	11
EK 8	8	26	4	23	17	26	32	25	6,5	52	26	38	11	6,6	12
EK 10	10	29	7	24	25	24	43	36	6	70	35	52	-	9	-
EK 12	12	29,5	7	24	25	24	43	36	6	70	35	52	-	9	-
EK 15	15	33	7	25	30	25	49	41	6	80	40	60	-	11	-
EK 20	20	48	10	42	30	25	58	56	10	95	47,5	75	-	11	-

Supporti di tipologia ad appoggio EF, BF e FF
Floated-side support unit types EF, BF and FF



EF 6-8



EF 10-20

Tipo Type	Dimensioni - Dimensions											
	d ₀	L ₃	H _{±0,02}	H ₁	H ₂	A	E	e _{±0,02}	F	S ₁	S ₂	S ₃
mm												
EF 6	6	12	13	20	25	18	42	21	30	9,5	5,5	11
EF 8	6	14	17	26	32	25	52	26	38	11	6,6	12
EF 10	8	20	25	24	43	36	70	35	52	-	9	-
EF 12	10	20	25	24	43	36	70	35	52	-	9	-
EF 15	15	20	30	25	49	41	80	40	60	-	9	-
EF 20	20	26	30	25	58	56	95	47,5	75	-	11	-

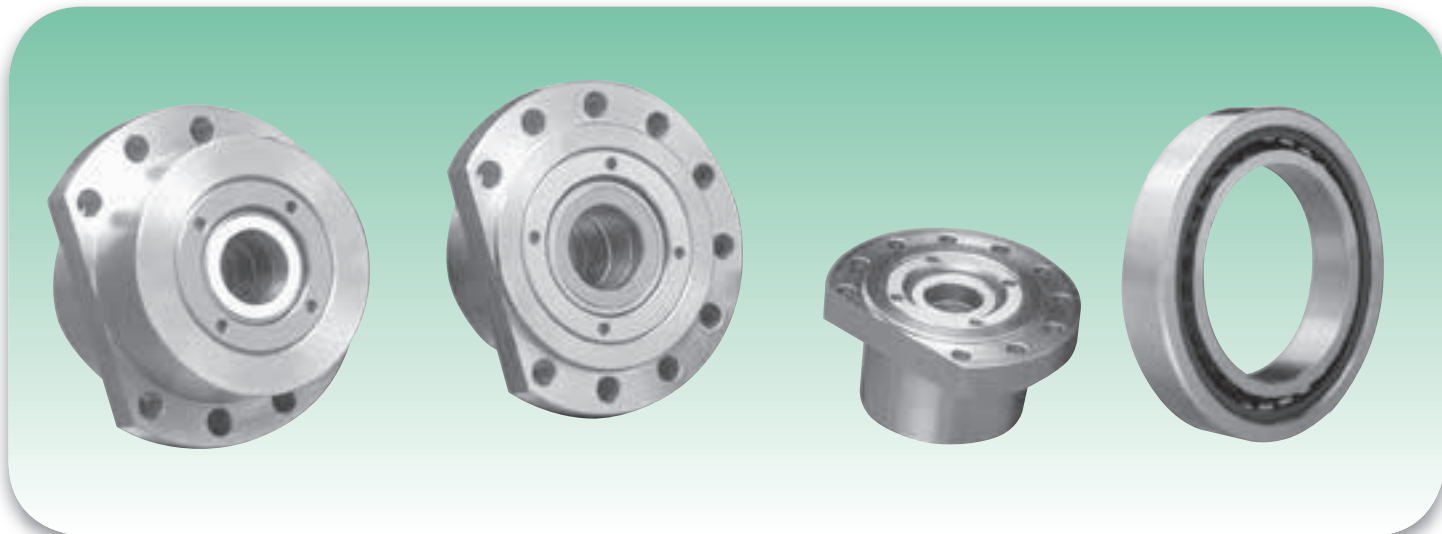
CARATTERISTICHE TECNICHE
TECHNICAL CHARACTERISTICS

- **Materiale**
Supporto: Acciaio C40 rettificato.
- **Cuscinetti:** ISB assiali a contatto obliquo della serie dimensionale ISO 02 (codice equivalente: FAG 76020) angolo di contatto 60°.
- **Classe di precisione:** Tolleranze ridotte nella classe di precisione ISO P4 corrispondente alla classe ISO P4S.
- **Pre-carico:** I cuscinetti sono prodotti in esecuzione universale. I valori di pre-carico sono indicati nella seguente tabella e corrispondono a valori di pre-carico elevati. Possono essere forniti coppie e quaterne con valori di pre-carico a richiesta.
- **Material**
Bearing unit: C40 rectified steel.
- **Bearings:** Angular contact thrust ball bearings ISB of dimensional series ISO 02 (equivalent code: FAG 76020). Contact angle 60°.
- **Precision class:** Reduced tolerances in ISO P4 precision class, corresponding to ISO P4S.
- **Pre-load:** Bearings are produced in universal execution. Preload values are indicated in the following table and correspond to high preload values. Couples and quaternary groups of pre-load values can be provided by specific request.

Supporti con cuscinetti di precisione assiali a contatto obliquo
Supports with precision axial angular contact bearings

• **Forza di serraggio:**

In presenza di una forza di serraggio eccessiva, gli anelli dei cuscinetti subiscono una deformazione elastica che provoca un aumento della forza di pre-ricarico ed una diminuzione della durata. Il valore della forza di serraggio può essere calcolata, con l'ausilio della tabella sotto riportata.

• **Tolleranze:** Le tolleranze di lavorazione e le dimensioni di montaggio sono indicate nelle tabelle a seguire:

• **Clamping force:**

In case of very strong clamping force, bearings rings are affected by an elastic deformation that causes an increase of the pre-load force together with a shortening of the duration. The value of the clamping force can be calculated by means of the table below.

• **Tolerances:** The following table reports the working tolerances and the mounting dimensions:

FORZE DI SERRAGGIO F ₂ CONSIGLIATE - RECOMMENDED F ₂ CLAMPING FORCES							
Disposizione cuscinetto <i>Position of the bearing</i>							
F _z [N]	3 - F _v		4 - F _v			6 - F _v	
Filettatura <i>Thread</i>	M5	M6	M8	M10	M12	M14	M16
Fattore F <i>Factor F</i>	0,98	1,18	1,55	1,9	2,35	2,7	30,5

La forza di serraggio F₂ viene raggiunta quando le viti del coperchio vengono serrate con la coppia M.

$$M = Fz/f[Nmm]$$

N = Numero di viti del coperchio

f. = Fattore di correzione

Clamping force F₂ is achieved when the cover's ball screws are clamped with the M couple.

$$M = Fz/f (Nmm)$$

N = number of cover's ball screws

f. = Correction factor

TOLLERANZE DI LAVORAZIONE DEGLI ALBERI E DELLE PARTI ADIACENTI

WORKING TOLERANCES OF SHAFT AND ADJACENT PARTS

VALORI INDICATIVI PER LA LAVORAZIONE DEGLI ALBERI VALUES FOR PROCESSING SHAFTS							
Dimensione nominale dell'albero (d) <i>Shaft's nominal dimension (d)</i>	Dimensioni - Dimensions						
	mm						
	Oltre / Over	10	18	30	50		
	fino a / up to	10	18	30	50	80	
CUSCINETTI ASSIALI A SFERE A CONTATTO OBLIQUO A SEMPLICE EFFETTO SIMPLE EFFECT ANGULAR CONTACT AXIAL BALL BEARINGS							
Scostamento (d) <i>(d) deviation</i>		-9	-11	-13	-15		
Precisione di forma cilindrica <i>Cylindrical form precision</i>	t1	2,5	2,5	3	4		
Precisione assiale di rotazione <i>Axial rotation precision</i>	t3	2,5	2,5	3	4		
Valore medio di rugosità <i>Roughness mean value</i>	Ra	0,4	0,4	0,4	0,4		

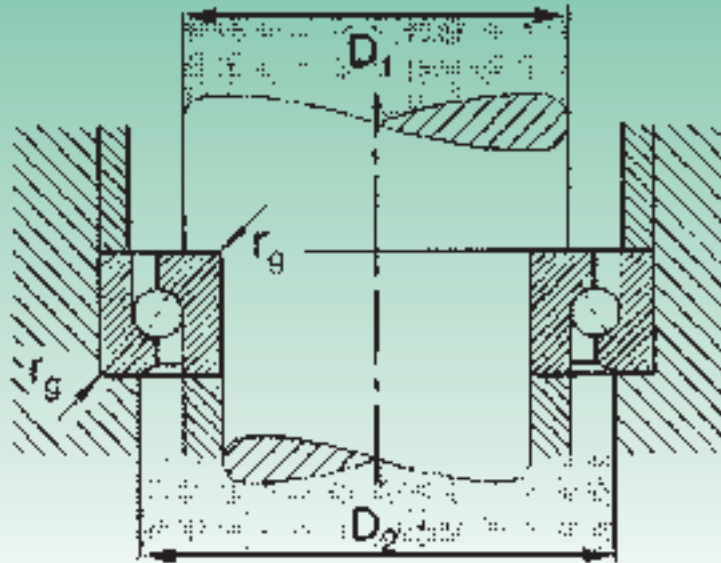
Supporti con cuscinetti di precisione assiali a contatto obliquo
Supports with precision axial angular contact bearings

DIMENSIONI DI MONTAGGIO PER CUSCINETTI ASSIALI A SFERE A CONTATTO OBLIQUO
MOUNTING DIMENSIONS FOR ANGULAR CONTACT AXIAL BALL BEARINGS

Albero Shaft	Cuscinetto tipo ISB 204714 AC (equivalente Fag 76020) 204714 AC ISB type bearing (Fag 76020 equivalent)		
Fore Bore	D1	D2	rg
mm	min	min	max
12	17	27	0,6
15	20,5	30	0,6
17	23	34,5	0,6
20	27,5	39,5	0,6
25	32	45	1
30	39,5	52,5	1
35	46,5	60,5	1
40	53,5	69,5	1
45	57	73	1
50	63	79	1

- Tenute:** I segmenti lamellari fey a 3 anelli espansori singoli, tipo FK3 AS, costruiti in acciaio per molle C75, creano una classica tenuta a labirinto.
- Lubrificazione:** Grassi al sapone di litio, con additivi EP come ad esempio il grasso ARCANOL L 135V, consistenza 2, °C – 40 + 150. I supporti sono già forniti lubrificati, con la quantità indicata nella tabella seguente.
- Seals:** Spathic segments fey with three expander rings, FK3 AS type, made of steel for stainless steel C75 springs, create a typical labyrinth seal.
- Lubrication:** Lithium soap greases with EP additives like ARCANOL L 135V grease, consistency 2, °C-40 + 150. Bearing units are supplied when already lubricated in the quantity indicated in the next table.

Supporti con cuscinetti di precisione assiali a contatto obliquo
Supports with precision axial angular contact bearings

Quantitativi di grasso per cuscinetti assiali a sfere a contatto obliquo, ad una corona.
Quantities of grease for angular contact axial ball bearings, single row.

Sigla Fag <i>Type Fag</i>	7602020TVP	7602025TVP	7602030TVP	7602035TVP
grasso g. / grease g.	1,42	1,95	2,65	3,7
Sigla Fag <i>Type Fag</i>	7602040TVP	7602045TVP	7602050TVP	
grasso g. / grease g.	4,45	5,35	6,5	

• **Accessori:** Ghiere di precisione rettificata con fissaggio a grani, serie ZM.

• **Tools:** Precision ground lock-nuts with dowel fixing, ZM series.

ESECUZIONI UNITÀ CARTUCCIA FLANGIATA
UNITY EXECUTIONS - FLANGED CARTRIDGE

Tipo <i>Type</i>	Descrizione <i>Specification</i>
ISB FD	FLANGIATA CON 2 CUSCINETTI A 'O' <i>FLANGED WITH 2 'O' BEARINGS</i>
ISB FQ	FLANGIATA CON 4 CUSCINETTI A 'O' <i>FLANGED WITH 4 'O' BEARINGS</i>
ISB FDX	FLANGIATA CON 2 CUSCINETTI A 'X' <i>FLANGED WITH 2 'X' BEARINGS</i>
ISB FQX	FLANGIATA CON 4 CUSCINETTI A 'X' <i>FLANGED WITH 4 'X' BEARINGS</i>

TABELLA DI CORRISPONDENZA
EQUIVALENT TABLE

Tipo ISB <i>ISB Type</i>	SNFA	FAFNIR	RHP
ISB FD	BSDU DD	BSBU D	BSCU D
ISB FQ	BSQU TDT	BSBU Q	BSCU Q
ISB FDX	BSDU FF	-	-
ISB FQX	BSQU TFT	-	-

CODICE DI IDENTIFICAZIONE
SPECIFICATION CODE

ISB	F	D	X	030	precarico da N <i>pre-load from N</i>		
MARCA <i>BRAND</i>	ESECUZIONE FLANGIATA <i>FLANGED EXECUTION</i>	D=2 CUSCINETTI Q=4 CUSCINETTI D=2 BEARINGS Q=4 BEARINGS	Nessun codice	No code	FORO CUSCINETTO <i>BEARING BORE</i>	Nessun numero: esecuzione	Without number: execution
					020 = 20 MM	precarico.	pre-load.
					025 = 25 MM	universale	universal
			esecuzione a	of execution	030 = 30 MM	Con numero:	With number:
			'O'	'O'	035 = 35 MM	precarico	pre-load
			X per	X for	040 = 40 MM	Speciale X	Special X
			esecuzione a	execution in	045 = 45 MM	360=360 da N	360=360 from N
			'X'	'X'	050 = 50 MM		

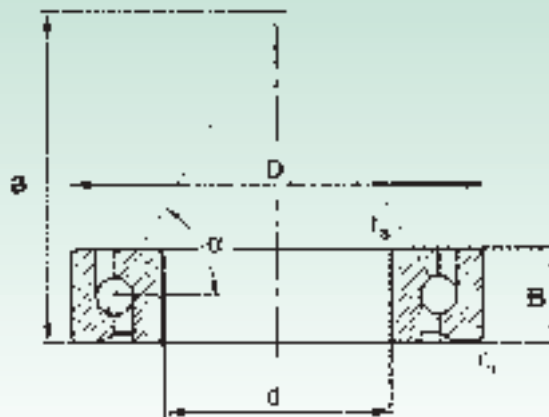

204714 AC

 Angolo di contatto $\alpha \approx 60^\circ$ - Contact Angle $\alpha \approx 60^\circ$

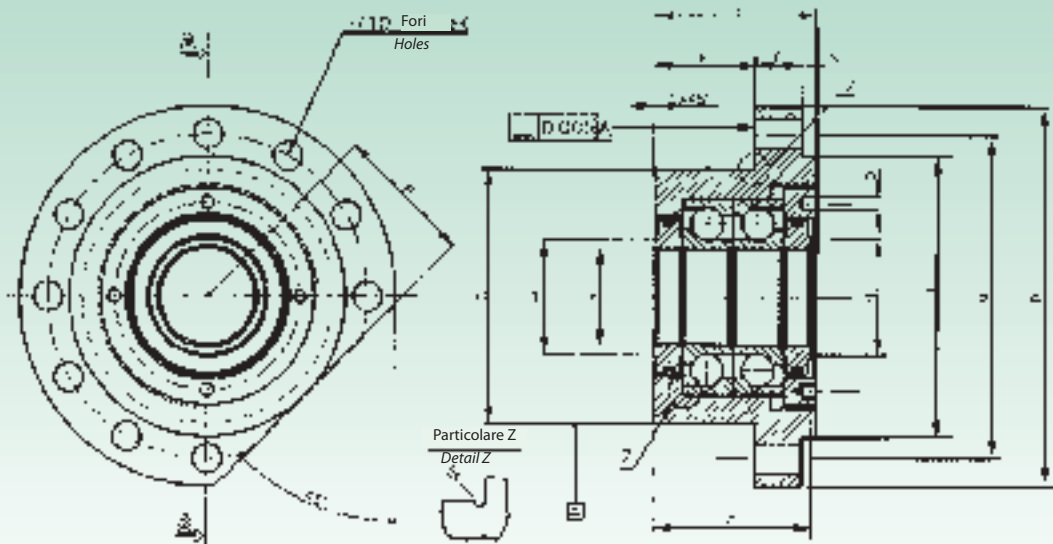
Cuscinetti ISB Bearings	Equivalente FAG Equivalent	Dimensioni - Dimensions					Capacità di carico Load ability		Carico assiale Axial load max	Velocità rotazione raggiungibile Achievable rotation speed		Forza di pre-carico Pre-load force	Momento d'attrito Friction point	Peso Weight
							din.	Stat.		Grasso Grease	Olio Oil			
Tipo Type	Tipo Type	d	D	B	rsmin	a ≈	C	Co	din	Velocità - Speed		Fv	Mr	Kg
mm						KN				kN		Nmm		
174012AC	7602017TVP	17	40	12	0,6	31	16,6	20	8,5	6000	8000	1,7	30	0,075
204714AC	7602020TVP	20	47	14	1	6	19,3	25	10,6	5000	6700	2,3	50	0,130
255215AC	7602025TVP	25	52	15	1	41	22	30,5	13,2	4500	6000	2,5	65	0,160
306216AC	7602030TVP	30	62	16	1	48	26	39	17	3800	5000	2,9	85	0,240
357217AC	7602035TVP	35	72	17	1,1	55	30	50	21,2	3200	4300	3,3	115	0,345
408018AC	7602040TVP	40	80	18	1,1	62,5	37,5	64	28	2800	3800	4,3	170	0,445
458519AC	7602045TVP	45	85	19	1,1	66	38	68	28	2800	3600	4,5	190	0,505
509020AC	7602050TVP	50	90	20	1,1	71,5	39	75	31,5	2400	3400	4,9	230	0,575

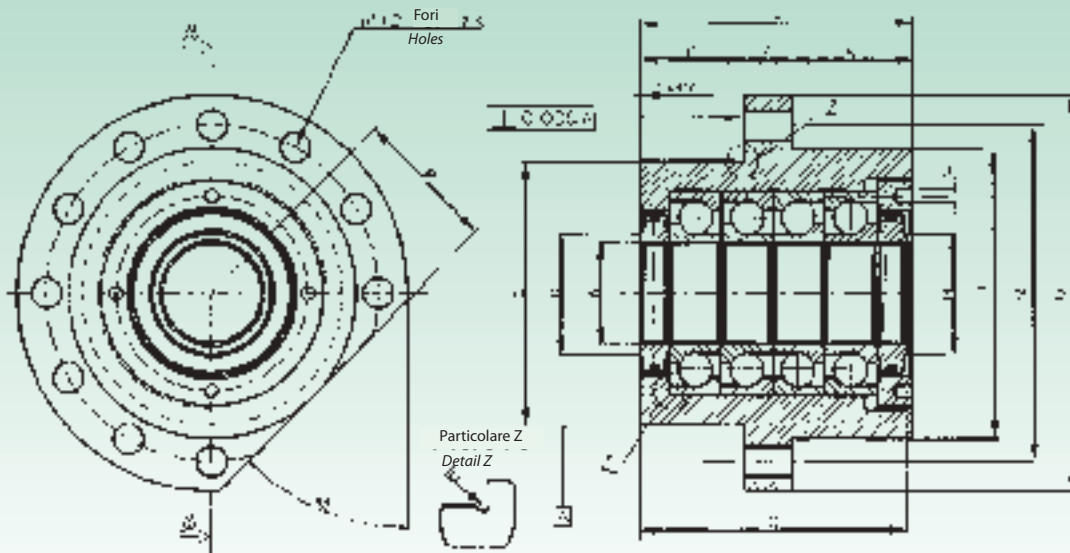

ALBERO Ø mm. SHAFT Ø mm.	Tipo Type	SUPPORTI ISB TIPO FD PER CUSCINETTI - DIMENSIONI SENZA TOLLERANZA: ± 0.13 mm. ISB UNITS TYPE FD, FOR BEARINGS - DIMENSIONS WITHOUT TOLERANCE: ± 0.13 mm.															
		A	B	C	D	E	F	G	H	I	K	M	N	P	Q	Rc	
17	ISB FD 017 (17-40-12)	17 16.996	25	60 59.987	90	32	13	44.260 43.240	47	64	6,6	76	2	32	4,3	0,5	
20	ISB FD 020 (20-47-14)	20 19.669	28	60 59.987	90	32	13	44.260 43.240	47	64	6,6	76	2	32	4,3	0,5	
25	ISB FD 025 (25-52-12)	25 24.996	35	80 79.987	120	32	15	50.260 49.240	52	88	9,2	102	5	44	4,3	0,5	
30	ISB FD 030 (30-62-12)	30 29.996	41	80 79.987	120	32	15	50.260 49.240	52	88	9,2	102	5	44	4,3	0,5	
35	ISB FD 035 (35-72-17)	35 34.995	46	90 89.987	130	32	15	50.260 49.240	52	98	9,2	113	5	49	4,3	0,5	
40	ISB FD 040 (40-80-18)	40 39.995	55	124 123.982	165	43,5	17	64.260 63.240	66	128	11,4	146	5,5	32	5,3	0,5	
45	ISB FD 045 (45-85-19)	45 44.995	66	124 123.982	165	43,5	17	64.260 63.240	66	128	11,4	146	5,5	44	5,3	0,5	
50	ISB FD 050 (50-90-20)	50 49.995	66	124 123.982	165	43,5	17	64.260 63.240	66	128	11,4	146	5,5	44	5,3	0,5	



ALBERO Ø mm. SHAFT Ø mm.	Tipo Type	SUPPORTI ISB TIPO FD PER CUSCINETTI - DIMENSIONI SENZA TOLLERANZA: ± 0.13 mm. ISB UNITS TYPE FD, FOR BEARINGS - DIMENSIONS WITHOUT TOLERANCE: ± 0.13 mm.														
		A	B	C	D	E	F	G	H	I	K	M	N	P	Q	Rc
17	ISB FQ 017 (17-40-12)	17 16.996	25	60 59.987	90	32	13	74.260 72.740	77	64	6,6	76	32	32	4,3	0,5
20	ISB FQ 020 (20-47-14)	20 19.669	28	60 59.987	90	32	13	74.260 72.740	77	64	6,6	76	32	32	4,3	0,5
25	ISB FQ 025 (25-52-15)	25 24.996	35	80 79.987	120	32	15	80.260 78.240	82	88	9,2	102	35	44	4,3	0,5
30	ISB FQ 030 (30-62-16)	30 29.996	41	80 79.987	120	32	15	80.260 78.740	83	88	9,2	102	36	44	4,3	0,5
35	ISB FQ 035 (35-72-17)	35 34.995	46	90 89.987	130	32	15	84.260 82.740	86	98	9,2	113	39	49	4,3	0,5
40	ISB FQ 040 (40-80-18)	40 39.995	55	124 123.982	165	43,5	17	104.260 102.740	106	128	11,4	146	45,5	64	5,3	0,5
45	ISB FQ 045 (45-85-19)	45 44.995	66	124 123.982	165	43,5	17	104.260 102.740	106	128	11,4	146	45,5	64	5,3	0,5
50	ISB FQ 050 (50-90-20)	50 49.995	66	124 123.982	165	43,5	17	104.260 102.740	106	128	11,4	146	45,5	64	5,3	0,5

Introduzione

Le forniture dei prodotti, presenti in questo documento, sono regolate dalle seguenti condizioni generali di vendita. Sarà necessario un preventivo accordo scritto con il Fornitore per ulteriori ed eventuali clausole e/o condizioni particolari

richieste dai Clienti. Sono da ritenersi inaccettabili, tutte le clausole e/o condizioni contrattuali in contrasto con quanto sotto riportato.

1) Offerte ed ordini

Le offerte mantengono una validità di 30 giorni dalla data di comunicazione al Cliente. Decorso questo termine senza avere ricevuto l'ordine, il Fornitore avrà la facoltà di accettare o non accettare l'ordinazione tardiva. Tutti gli ordini dovranno indicare sempre la tipologia del prodotto, la quantità e la data di consegna richiesta.

Il Fornitore si riserva il diritto di fornire eventualmente altri prodotti aventi le stesse caratteristiche merceologiche di quelli ordinati. Gli ordini sono da intendersi impegnativi per il Cliente, anche senza la forma scritta. Il Fornitore avrà il medesimo obbligo al momento dell'invio della conferma d'ordine (escluse le eccezioni ai punti due e cinque).

2) Prezzi

I prezzi validi di riferimento sono quelli indicati nell'offerta e/o nell'accettazione dell'ordine e sono riferiti solo a prodotti standard. I prezzi relativi a tipologie speciali di prodotto e/o non standard ovvero a richiesta specifica del Cliente, saranno concordati per ogni singolo ordine di volta in volta tra le parti. Il Fornitore si riserva il diritto, per esigenze produttive e/o d'approvvigionamento, di fornire una quantità di prodotto con variazione pari a $\pm 15\%$ rispetto alla quantità concordata con il Cliente. Nel corso delle diverse forniture qualora dovessero verificarsi degli aumenti causati da variazioni quali: aumento delle materie prime, del costo della mano d'opera del costo dei trasporti, delle imposte e dazi, ed anche altri aumenti che comportino aumenti del prodotto per il Fornitore, questo potrà a proprio insindacabile giudizio adeguare i prezzi, comunicando l'entità di tale aumento al Cliente. Le quotazioni dei prodotti, sono da intendersi franco sede del Fornitore, escluso imballo ed IVA.

3) Consegna

La consegna, è da intendersi terminata ed eseguita nel momento in cui i prodotti sono messi a disposizione del Cliente al banco, presso la sede del Fornitore o con la consegna al vettore/spedizioniere. Se il Cliente non ha dato precise istruzioni sulle modalità di spedizione dei prodotti o non ha provveduto in modo celere al loro ritiro, il Fornitore potrà conservarli presso i propri locali; a rischio e pericolo ed a spese del Cliente, senza alcuna responsabilità per la loro conservazione o spedirli con mezzi propri o corrieri di propria scelta.

4) Termini di consegna

I termini di consegna indicati dal Fornitore, sono indicativi e non hanno carattere essenziale e perentorio. La loro inosservanza non costituirà in alcun caso motivo di risoluzione del contratto e/o risarcimento d'alcun danno di qualsiasi natura. I termini saranno rispettati per quanto possibile, poiché la consegna dipende da soggetti terzi rispetto al Fornitore. Il Fornitore potrà risolvere il contratto e/o modificare i termini di consegna, senza che ciò possa costituire in alcun modo motivo di risarcimento e/o pagamento d'indennità per eventuali danni subiti dai Clienti, nei seguenti casi:

- I. Inadempienza dei pagamenti e/o pendenze debitorie da parte del Cliente.
- II. Difficoltà in fase d'approvvigionamento dei prodotti.
- III. Modifiche alle condizioni contrattuali dopo il ricevimento dell'ordine.
- IV. Eventi di causa e/o forza maggiore, non imputabili alla volontà del Fornitore, quali a titolo di esempio scioperi di vario genere, calamità naturali, epidemie, sommosse, tumulti, guerre, blocchi doganali che possono gravare sul Fornitore stesso o sulle sue fonti d'approvvigionamento.
- V. Inesattezze o ritardi da parte del Cliente nella conferma dell'ordine.

Per i fatti riportati ai punti I-III-V il Fornitore potrà chiedere il risarcimento dei danni al Cliente.

Introduction

The supply of the products covered by this document is governed by the following general conditions of sale. Any additional clauses and/or special conditions requested by Customers shall only be valid in case of prior written agreement with the Supplier. All contract clauses and/or conditions in conflict with the terms set out below shall be considered unacceptable.

1) Offers and orders

Offers are valid for 30 days from the date of communication to the Customer. If no order is received within this period, the Supplier shall have the option of accepting or rejecting late orders, at its own discretion. All orders must always state the type of product, the quantity and the delivery date required. The Supplier reserves the right to supply different products with the same characteristics as those ordered. Orders are binding on the Customer even if not in writing. Orders shall also be binding on the Supplier once the confirmation of order has been dispatched (with the exceptions in points two and five below).

2) Prices

The valid reference prices are those stated in the offer and/or the order acceptance, and refer to standard products only. The prices relating to special and/or nonstandard product types, or to specific requests from the Customer, shall be agreed between the parties for each order on a one-off basis. Depending on production and/or procurement requirements, the Supplier reserves the right to supply a quantity of product with variation of $\pm 15\%$ from the quantity agreed with the Customer. Over a series of shipments, if increases occur due to variations such as increases in raw material costs, in the cost of labour, freight costs, taxes and duties, or any other increases which lead to increases in the cost of the product for the Supplier, the latter may adjust the prices accordingly, at its own absolute discretion, informing the Customer of the amount of any such increase. Quotations for products are ex-works Supplier's factory, not including packaging or VAT.

3) Delivery

Delivery is considered to have taken place when the products are placed on the Customer's disposal on the counter on the Supplier's premises, or on consignment to the carrier/forwarding agent. If the Customer has not given clear instructions concerning the procedures for shipment of the products, or has not arranged for their prompt collection, the Supplier may store them on its own premises, at the Customer's risk and expense, without any responsibility for their conservation, or may ship them using its own vehicles or carriers of its choice.

4) Delivery terms

The delivery terms stated by the Supplier are guideline and not binding. In no case shall failure to meet them constitute grounds for termination of the contract and/or for compensation for any damage of any kind. Delivery terms shall be complied with as far as possible, since delivery depends on third parties over which the Supplier has no control. The Supplier may terminate the contract and/or modify the delivery terms, without this constituting grounds for compensation and/or payment of damages for any costs or losses incurred by the Customer, in the following cases:

- I. Failure to meet payment terms and/or outstanding debts on the part of the Customer.
- II. Difficulty in procurement of the products.
- III. Modifications of the contract conditions after receipt of the order.
- IV. Circumstances of force majeure, beyond the Supplier's control, such as, for example, strikes of various kinds, natural disasters, epidemics, uprisings, riots, wars or customs blockades which may affect the Supplier itself or its sources of supply.
- V. Inaccuracies or delays on the part of the Customer in confirming the order.

In the circumstances listed in points I-III-V, the Supplier may request compensation from the Customer.

5) Spedizioni

Le spedizioni sono sempre eseguite per conto dei Clienti, pertanto a loro rischio e pericolo, anche nei casi di trasporti "franco destino". Nel caso d'eventuali manomissioni o ammanchi imputabili espressamente al vettore/spedizioniere, sarà obbligo del Cliente stesso di presentare reclamo direttamente al vettore/ spedizioniere. Il Fornitore, potrà accettare reclami per eventuali differenze, qualitative e quantitative dei prodotti, solamente se comunicate da parte del Cliente, in forma scritta entro otto giorni dalla data di ricevimento dei prodotti, a pena di decadenza da ogni e qualsiasi reclamo. In mancanza d'istruzioni dettagliate da parte del Cliente, il Fornitore non sarà responsabile, sia per la scelta dei mezzi di trasporto, sia per le tariffe e applicate dai vettori/spedizionieri. Inoltre qualora non sussista accordo tra le parti, le spese di spedizione sono da intendersi a cura ed a carico del Cliente. Nei casi in cui anche solo una parte delle spese di trasporto sia a carico del Fornitore, quest'ultimo potrà servirsi dei mezzi più economici a propria insindacabile scelta. Gli ulteriori aggravii e oneri aggiuntivi nei costi di trasporto saranno ad esclusivo carico del Cliente. Per errori di consegna causati dal Cliente, con conseguente reso dei prodotti, il Fornitore avrà il diritto di addebitare al Cliente le spese di spedizione se dovute, ed il 15% del prezzo dei prodotti.

6) Pagamenti

Il Cliente non potrà sospendere ovvero ritardare i pagamenti della merce per nessun motivo e dovranno essere eseguiti al domicilio del Fornitore, come indicato nei documenti che accompagnano la spedizione dei prodotti. Non saranno considerati validi pagamenti effettuati in luoghi diversi, salvo che non siano stati concordati preventivamente con il Fornitore. Decorso i termini indicati, il Fornitore avrà diritto al pagamento, oltre alla somma capitale dovuta per il prezzo della merce, anche agli interessi di mora pari all'Euribor aumentato del 3%, avvalendosi del diritto d'agire anche giudizialmente nei confronti del Cliente moroso. Il Fornitore ha la facoltà di sospendere temporaneamente la fabbricazione o la fornitura dei prodotti ancora in ordine; inoltre potrà annullare il residuo dell'ordine stesso, comunicandolo al Cliente, che non avrà diritto ad indennizzi d'alcun genere. Il Fornitore avrà il diritto di ottenere il pagamento delle somme dovutegli per le consegne già eseguite. Per ogni contestazione inerente a prodotti in corso di fabbricazione, pronti per essere spediti o già in possesso del Cliente, quest'ultimo non è liberato dai propri obblighi e dovrà provvedere al pagamento, alla data stabilita, di quanto dovuto al Fornitore.

7) Garanzia

La garanzia s'estende per un anno dalla data di consegna dei prodotti; è limitata esclusivamente alla riparazione o alla sostituzione gratuita dei pezzi riconosciuti non conformi rispetto alle specifiche riportate sui cataloghi tecnici. La responsabilità della garanzia del Fornitore decade per tutti i prodotti che hanno subito manomissioni, sovraccarichi d'esercizio, lubrificazioni, riparazioni errate o errori in fase di montaggio, quindi per problemi causati da un utilizzo improprio del Cliente e pertanto non più restituibili al Fornitore. Il Cliente inoltre è tenuto ad avvertire il Fornitore per eventuali difetti, vizi o non conformità dei prodotti entro otto giorni dal ricevimento degli stessi (in forma scritta), pena la decadenza della garanzia. Non saranno accettati reclami trascorsi i termini sopra citati. I reclami non possono causare l'annullamento o la riduzione degli ordini da parte del Cliente, né la corresponsione d'indennizzi e/o risarcimenti da parte del Fornitore. Non si accettano ritorni di prodotti, se non preventivamente autorizzati. Non si accettano ritorni di forniture, per prodotti resi non integri o manomessi o espressamente costruiti, lavorati e/o modificati per il Cliente. Il materiale non conforme dovrà essere reso previa autorizzazione del Fornitore, esente da ogni spesa (franco destino). Sul documento di reso dovranno essere riportati gli estremi del DDT o fattura di vendita relativa (Data e n° - obbligatorio per legge). Il Fornitore non assume alcuna responsabilità per incidenti che possano avvenire nell'utilizzo dei propri prodotti.

5) Shipments

Shipments are always made on the Customer's behalf and therefore at its risk, even in case of delivery "freight prepaid". In case of tampering or missing items for which the carrier/forwarding agent is specifically to blame, the Customer shall be responsible for placing a claim directly with the carrier/forwarding agent. The Supplier will only be able to accept claims for any differences in the quality or quantity of the products if submitted by the Customer, in writing within eight days after the date of receipt of the products; otherwise, all claims shall become null and void. In the absence of detailed instructions from the Customer, the Supplier shall not be responsible for the choice of means of transport or for the rates charged by the carriers/forwarding agents. Moreover, in the absence of agreement between the parties, the shipment expenses shall be payable by the Customer. If even just a part of the freight costs is to be met by the Supplier, the latter shall be permitted to make use of the most economical means of transport, at its own absolute discretion. Any additional freight costs and/or charges shall be solely for the Customer's account. For errors in delivery caused by the Customer which result in return of the products, the Supplier shall be entitled to charge the Customer the shipment expenses, if due, plus 15% of the price of the products.

6) Payment

The Customer shall not be permitted to suspend or delay payments for goods for any reason, and payments must be made to the Supplier's domicile, as stated in the documents which accompany the shipment of the products. Payments made to other places shall not be considered valid unless agreed in advance with the Supplier. Once the specified payment terms have passed, the Supplier shall be entitled to payment, not only of the capital sum due for the price of the goods, but also of interest at the Euribor rate increased by 3%, and retains the right to take legal action against any Customer late with payments. The Supplier shall be entitled to temporarily suspend the manufacture or supply of any products still on order; it may also cancel the remainder of the order, informing the Customer, which shall not be entitled to compensation of any kind. The Supplier shall be entitled to obtain payment of the sums due to it for the deliveries already made. In case of any disputes concerning products being manufactured, ready for shipment or already in the Customer's possession, the latter shall not be released from its obligations and must pay the amounts due to the Supplier at the date set.

7) Warranty

The warranty is valid for one year from the date of delivery of the products; it is limited solely to the repair or replacement, free of charge, of pieces acknowledged not to comply with the specifications stated in the technical catalogues. The Supplier's warranty ceases to apply to all products which have been tampered with, operated with overloads, improperly lubricated or repaired, or incorrectly assembled; in other words, for all problems caused by improper use by the Customer, for which the Supplier is not responsible. The Customer is also obliged to inform the Supplier about any defects, faults or non-conformity of the products within eight days after the date of receipt of the same (in writing); otherwise, the warranty shall become null and void. No claims shall be accepted once the above terms have expired. Claims shall not constitute grounds for the cancellation or reduction of orders on the part of the Customer, or the payment of damages and/or compensation on the part of the Supplier. No returns of products are accepted unless authorised in advance. No returns are accepted of products which are not intact, have been tampered with, or have been specifically built, processed and/or modified for the Customer. Non-conforming material must be returned, further to the Supplier's authorisation, with all expenses paid (freight prepaid). The return document must contain the details of the original transport document or invoice (date and number - compulsory by law). The Supplier does not accept any responsibility for accidents occurring during the use of its products.

8) Prodotti speciali e/o a disegno

Il Fornitore qualora accetti commesse di prodotti speciali o su particolari specifici che tecniche del Cliente, dovrà sempre ricevere un disegno tecnico dettagliato prima di procedere alla produzione. Dopo aver accettato l'ordine e previa consegna del disegno tecnico, il Fornitore invierà al Cliente una campionatura del prodotto. Il Cliente, dopo averne preso visione, dovrà inviare conferma scritta al Fornitore per l'esecuzione dell'intera fornitura. Nel caso in cui il Cliente per motivi non imputabili al Fornitore rifiutasse in modo parziale o completo la fornitura, il Fornitore potrà avvalersi del diritto di addebitare le spese per l'esecuzione della campionatura, oltre al mancato guadagno e per gli eventuali danni subiti, trattandosi di prodotti non commercializzabili. Il Fornitore provvederà al ritiro ed alla sostituzione del materiale non conforme, nel caso in cui il Cliente dimostrasse palesemente che le caratteristiche del prodotto fornito non corrispondono a quelle dei campioni consegnati, senza alcuna responsabilità da parte del Fornitore e con rinuncia del Cliente ad ogni richiesta di risarcimento a qualsiasi titolo richiesto.

9) Validità e deroghe delle Condizioni Generali di Vendita

Ogni e qualsiasi deroga o modifica alle sopra indicate condizioni generali di vendita, dovrà essere convenuta in forma scritta tra le parti.

10) Domicilio del Cliente

Il domicilio del Cliente è da intendersi quello ove il Cliente ha la propria sede legale, salvo diversa comunicazione scritta. Il Fornitore pertanto indirizzerà tutte le comunicazioni e le spedizioni dei prodotti in quella sede.

11) Foro competente

Per ogni e qualsiasi controversia sarà competente il foro dove si trova la sede legale del Fornitore.

8) Special and/or custom-made products

If the Supplier accepts orders for special products or those made to the Customer's own technical specifications, it must always receive a detailed technical drawing before proceeding with production. After accepting the order and further to consignment of the technical drawing, the Supplier shall send the Customer a sample lot of the product. After viewing the sample lot, the Customer shall send the Supplier written confirmation for production of the entire ordered amount. If, due to circumstances beyond the Supplier's control, the Customer refuses delivery of all or part of the goods, the Supplier shall be entitled to reimbursement of the expenses for production of the sample lot, and for compensation for loss of earnings and for any damages incurred, since these products are not marketable. The Supplier shall collect and replace non-conforming material if the Customer clearly demonstrates that the characteristics of the product supplied differ from those of the samples consigned, without any liability on the part of the Supplier and with waiver on the part of the Customer of any request for compensation on any grounds.

9) Validity and waivers of the General Conditions of Sale

Any waivers or modifications of the aforesaid general conditions of sale must be agreed between the parties in writing.

10) Customer's Domicile

The Customer shall be domiciled in the place where it has its registered office, unless otherwise notified in writing. The Supplier shall therefore send all communications and shipments of products to the relevant address.

11) Legal jurisdiction

The law court of the Supplier's registered office shall have jurisdiction over all disputes of any kind.





I N D U S T R I E S



©Copyright  B

È vietata la riproduzione anche parziale del contenuto di questo catalogo tecnico. Non si possono accettare responsabilità per eventuali errori od omissioni. Le misure, i disegni e le immagini non sono impegnativi. Marchio registrato Italia-EU.

The reproduction, even partial, of the contained concerning this technical catalogue, is forbidden. Liability for possible errors and/or omissions are not accepted. The measurements, drawings and images are not demanding.™ Registered in Italy-EU.



I N D U S T R I E S
SUPPORTI AUTOALLINEANTI
SELF-ALIGNING BEARING UNITS

01.09.2019 ©Copyright 



679991006F51A18121700