

Falk™ Omnibox® Worm Gear Drives

The Right Quality, The Right Performance  
(English-Inch)

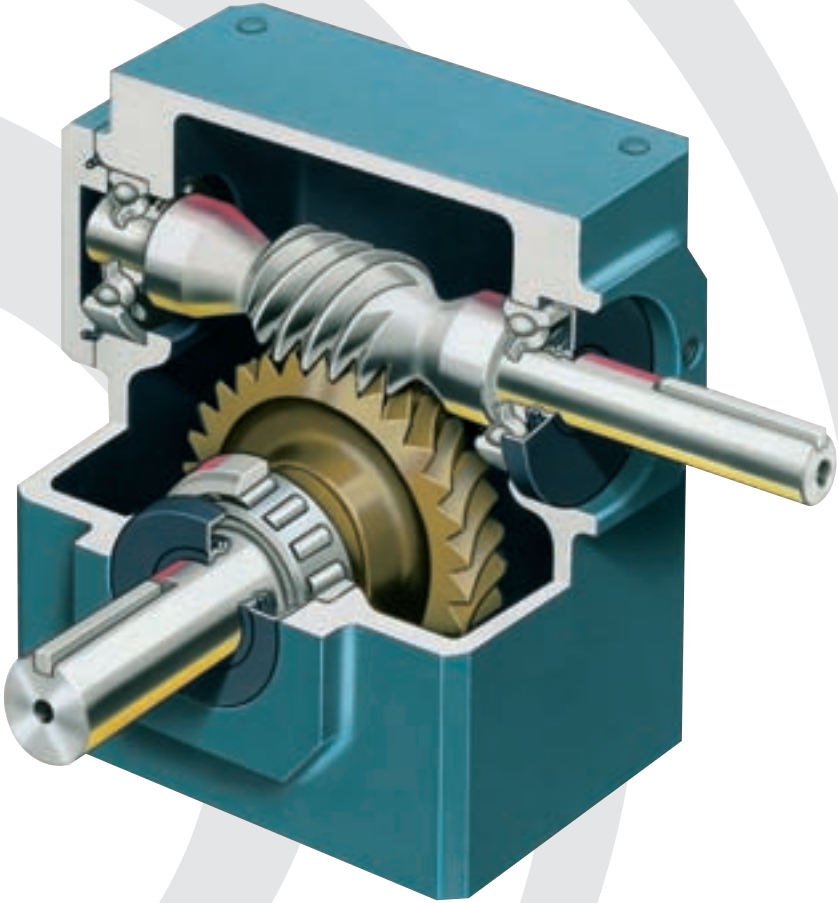

# FALK™ OMNIBOX®

## The High-Performance Choice for all Your Applications

When it comes to winning solutions to your right angle, small worm gear drive challenges, Omnibox has it all.

Omnibox incorporates our best durability and reliability features into one competitively priced product line.

Over 475,000 configurations mean there's one that's precisely right for virtually every application.

And Omnibox delivers all this quality and performance in a package that offers drop-in convenience for minimal downtime.

### Omnibox Truly is the Best of the Best

- Sizes: 1.33" through 10" centers
- Output speeds: .25 through 350 RPM
- Solid or hollow alloy-steel shafts
- Single or double ended outputs
- NEMA and IEC motor flanges
- Single reduction drives or double reduction drives in helical-worm or worm-worm configurations

### No Leaks

Omnibox is all about long life and low operating costs. Viton® Double Lip Seals, standard, deliver increased resistance to high temperature, abrasion and chemicals.

O-rings on input and output covers eliminate gaskets and silicone sealants that are prone to leaks. And the entire system is 100% run and leak tested.

Plus, a quill seal guard helps prevent input seal damage during motor installation. So Omnibox protects your investment right from the start.

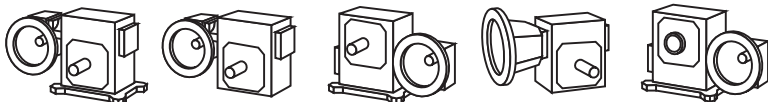
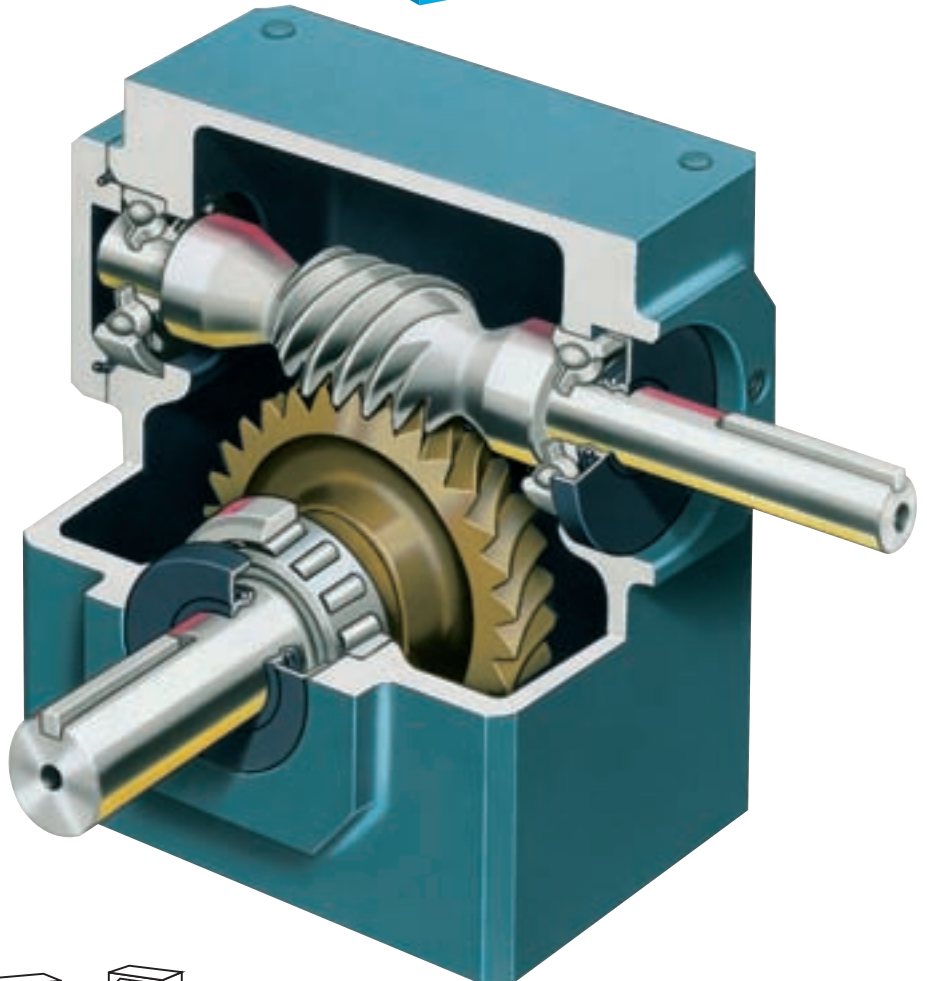
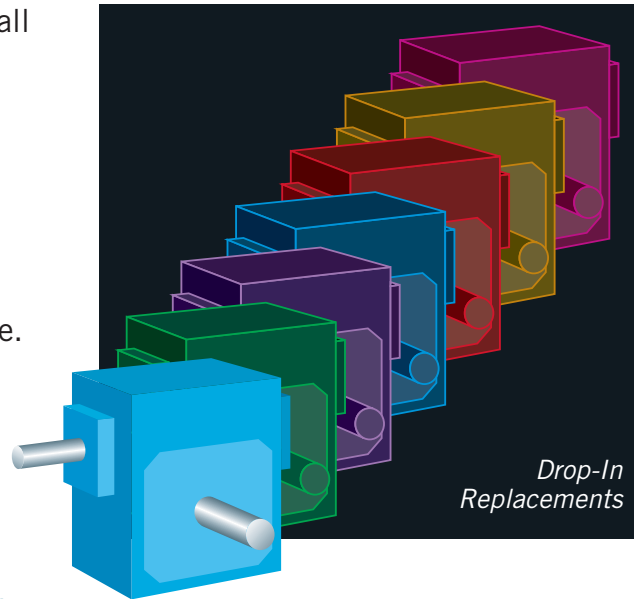

## Tough, Winning Performance

For top performance even in extreme work environments, Omnibox drives feature the strength and rigidity of cast iron housings. High-strength steel output shafts resist failure from starting and stopping torque, shock loads and fatigue, while low-speed, heavy-duty tapered roller bearings withstand high overhung and thrust loads.

## Quiet, Smooth Operation

The true measure of a champion is the ability to consistently deliver over time. Our non-compressible metal shims maintain factory bearing settings and gear alignment

throughout the life of the drive. The single cover output design ensures gear centering for maximum efficiency, with minimal noise levels.

In addition, chill-cast bronze gears help assure long, trouble-free life and quality operation. And hardened and precision ground worms feature high helix angles to provide the ultimate in efficiency and torque capacity.

## Special Application Drives

Our extensive product offering means Omnibox can meet your highly specialized drive needs, too. For example, where a sealed drive is essential, our Pressure

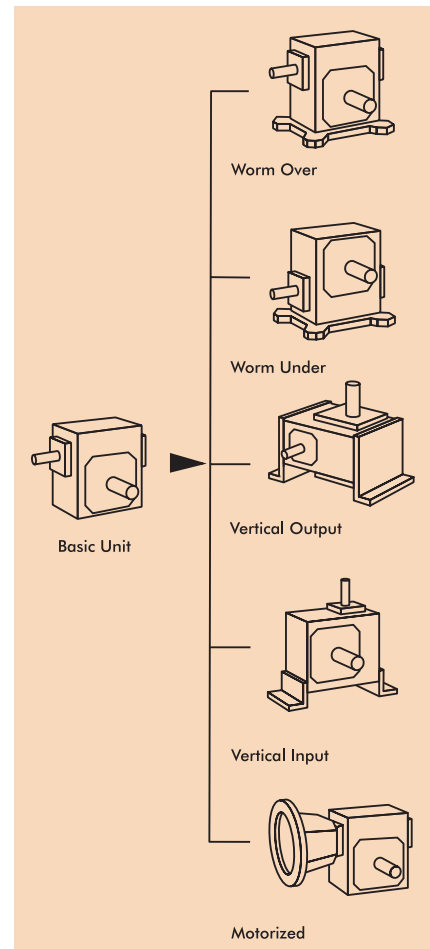

equalizing system assures long life with low maintenance. Stainless steel drives are available for harsh-duty environments.

And BISSC Certified drives accommodate the wash-down requirements of the food, chemical and pharmaceutical industries.

## Fast Answers; Fast Delivery

Local availability from Rexnord's extensive Distributor network and modular designs allow quick turnaround and delivery. Drop-in convenience helps further reduce your downtime. And our dedicated Small Drives Center assures prompt response to all your small drive service and support needs.

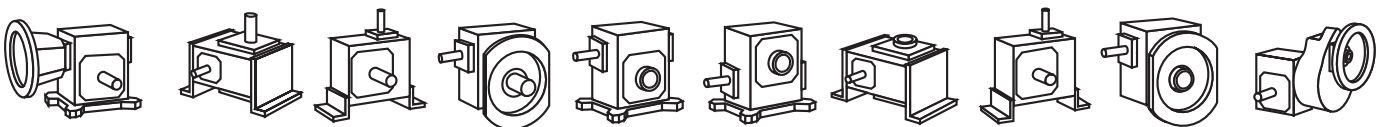

# Omnibox Selection Guide

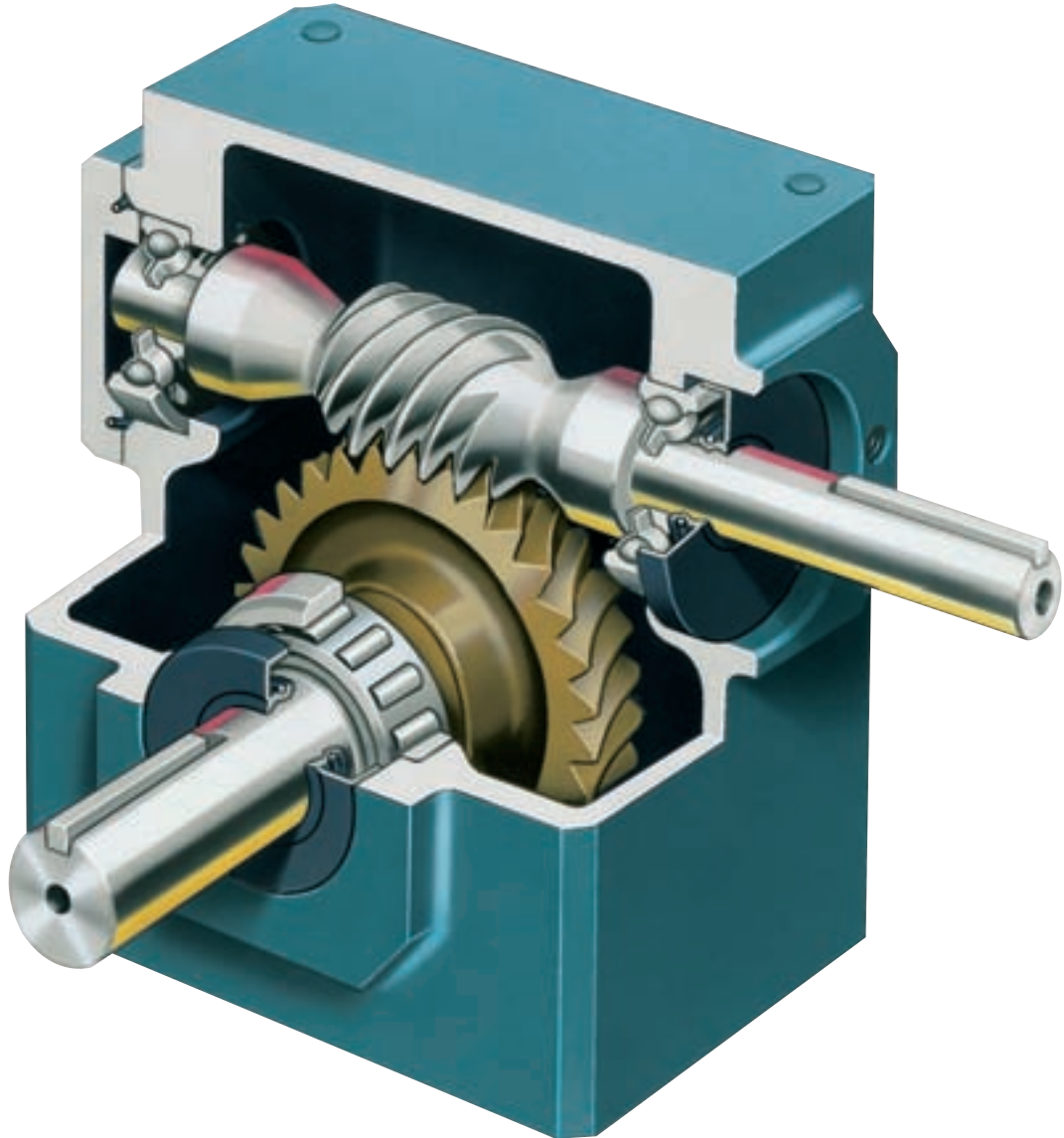

# Selection Guide 271-108, November 2000

## Table of Contents

### Omnibox General Information

Basic Information . . . . .	6
Conditions Affecting Selection . . . . .	7
How to Select and Order — Quick Selection Method . . . . .	8
Drive Nomenclature . . . . .	9
Service Factors . . . . .	10-11
Overhung Load and Thrust . . . . .	12-13
Selection Guide . . . . .	14-19
Exact Ratio & Ratio Combinations . . . . .	20-21

### Single Reduction

Quick Selection . . . . .	22-23
Horsepower & Torque Rating . . . . .	24-27
Dimensions . . . . .	28-51

### Double Reduction/Worm-Worm

Quick Selection . . . . .	52-53
Horsepower & Torque Rating . . . . .	54-57
Dimensions . . . . .	58-81

### Double and Triple Reduction/Helical-Worm

Horsepower & Torque Rating . . . . .	82-85
Dimensions . . . . .	86-117

### Overhead Conveyor Drive — WR

Horsepower & Torque Rating . . . . .	118-119
Dimensions . . . . .	120-129

### Helical and Worm Primaries

General Information . . . . .	130
Selection Procedure . . . . .	131
Helical Primary Horsepower & Torque Ratings . . . . .	132
Worm Primary Horsepower & Torque Ratings . . . . .	133
Helical Primary Dimensions . . . . .	134-135
Worm Primary Dimensions . . . . .	136-137

### Omnibox General Information

Availability & Compatibility of Accessories . . . . .	138-139
Additional Accessories . . . . .	140
Bolt Circle Dimensions . . . . .	141
Interchangeability Information . . . . .	142
Non-Preferred Mounting Positions . . . . .	143
Double Input Shafts . . . . .	144

## Reference Notes

### \* Refer to Page 143 for Omnibox Non-Preferred Mounting Positions.

- ‡ Refer to multiple chain, sprocket, and pinion mounted applications to Factory for Deflection Analysis.
- ▼ For Sizes 1700-11000, Primary Drive has hollow output shaft and Secondary input shaft is solid.
- ★ Drives are for horizontal operation unless specifically stated otherwise. Consult Factory for other mountings. Dimensions are for reference only and are subject to change without notice unless certified.
- Dimension "M" is the usable shaft extension length.
- ◆ Dimensions "O" & "OA" are the usable shaft extension lengths.
- Refer to Pages 138 and 139 for other bushing and L.S. shaft bores.
- \* Metric motor flanges are available in Types WBM, WOM, WUM, WXW, WJM, WLM, WBWM, WOWM, WUWM, WXWM, WJWM, WLWM, WRM, WRWM, & WPM only.
- ▲ For Size 1133, a second set of foundation holes are furnished, located as follows: F = 3.31", G = 1.66".
- ♣ BD = 5.88" on Sizes 1133 through 1206 quill-style WBHM, WBHQ, WOHM, WOHQ, WUHM, WUHQ, WXHM, WXHQ, WJHM, WJHQ, WLHM, & WLHQ drives.
- § Dimension "YA" is thickness of shims required under drive to permit helical head to clear foundation by .25 inches. Add "YA" to dimensions "D" & "V". Shims by purchaser.
- ♥ For Assemblies 3, 7, 11, 16, 19, 23, 27, 31, 43, & 47, dimension "YA" is the thickness of shims required under drive to permit helical head to clear the foundation by .25 inches. Add "YA" dimension to dimension "V". Shims by purchaser.
- ♠ Dimension "BD" for Size 1, Type HPF with Size 48C frame is 3.85"; Size 56C frame is 6.50".
- ⊛ Size 1, Type HPM with Size 48C frame: "BF" holes are rotated 45°.
- ♣ Must be Factory Assembled. Kit not available.

Copyright 1986, 2000. Rexnord Industries, LLC.  
All Rights Reserved. Litho in U.S.A. FALK, RAM, RENEW, REXNORD, STEELFLEX, ULTRAMAX, and OMNIBOX are registered trademarks. Viton is a registered trademark of DuPont Dow Elastomers.  
The contents of this selection guide are subject to change without notice or obligation. Information contained herein should be confirmed before placing orders.

---

# Basic Information

## Safety Notes

**Falk Gear Drives** The Falk and Rexnord name on the gear drive is the purchaser's assurance that the drive was engineered, rated and manufactured to sound design practices.

The power supplied to the geared drive must be equal to or less than the power for which the drive was selected using the appropriate service factor for the application. The customer must also assume the responsibility of isolating the geared drive from any vibratory or transient load induced by the driven equipment.

Install and operate Rexnord products in conformance with applicable local and national safety codes and per Rexnord installation manuals which are shipped with gear drives and are also available upon request. Suitable guards for rotating members may be purchased from Rexnord as optional accessories. Consult your local Rexnord Representative for complete details.

**People Conveying Equipment** Selection of Rexnord gear drives for applications whose primary purpose is the transportation of people is not approved. This includes such applications as freight or passenger elevators, escalators, man lift platforms, and ski tows and ski lifts.

If the primary purpose of the application is material conveyance and occasionally people are transported, the Rexnord warranty may remain in effect provided the design and load conditions are not exceeded and certification to the appropriate safety codes and load conditions has been obtained by the system designer or end user from the appropriate enforcement authorities.

## Gear Drive Ratings

All gear drive ratings in this selection guide allow 100% overload for starting loads and momentary overloads for electric motor driven applications operating ten hours per day under uniform conditions (unity service factor). For other conditions, compute an equivalent power by multiplying the actual power required for the application by the appropriate service factor.

**Gear Drive Identification** Tables in this selection guide identify gear drives by size, type and ratio. See Drive Identification Page 8.

**Horsepower & Torque** Drive mechanical horsepower and torque ratings are tabulated in the selection guide to permit selections for specific application requirements. NOTE: Drives may be selected using the Quick Selection tables under most circumstances. Refer to those tables starting on Page 23 for selection guidelines.

**Stored & Inactive Gear Drive** Each drive is protected with rust preventive that will protect parts against rust for a period of 6 months in an indoor dry shelter.

**Sizes 1133 through 1600** — If a drive is to be stored, or is inactive after installation beyond the above periods, drain oil from housing and spray all internal parts with a rust preventive oil that is soluble in lubricating oil or add "Motorstor" J vapor phase rust inhibitor at the rate of one ounce per cubic foot of internal drive space (or 5% of sump capacity) and rotate the shafts several times by hand. Before operating, drives which have been stored or inactive must be filled to the proper level with oil meeting the specifications given in Manual 278-109.

Periodically inspect stored or inactive gear drives and spray or add rust inhibitor every six months, or more often if necessary. Indoor dry storage is recommended.

Drives ordered for extended storage can be treated at the Factory with a special preservative and sealed to rust-proof parts for periods longer than those cited previously.

**Factory Warranty** Falk products generally carry a limited, 1.5 year warranty against defects in materials or workmanship; but, for an actual statement of the Factory Warranty, or a Falk/Rexnord Distributor for our Standard Conditions of Sale, refer to the Factory.

---

# Conditions Affecting Selection

## Non-Standard Application Procedures

The following conditions may affect the Omnibox gear drive selection procedure, drive size, and auxiliary equipment being furnished.

**Excessive Overloads** The maximum momentary or starting load must not exceed 200% of rated load (100% overload). Rated load is defined as gear drive rating with a service factor of 1.0. If the maximum starting or momentary load exceeds the above conditions, compute a second equivalent power rating by dividing the peak load by two. The gear drive selected must have capacity equal to, or in excess of, the larger equivalent power rating.

**Reversing Service** Applications involving either more than 20 reversals per ten hour period, or less than 20 reversals per ten hour period with peak torques greater than 200% of normal load must be referred to Factory.

**Brake Equipped Applications** When a gear drive is equipped with a “working” brake that is used to decelerate the motion of the system and the brake is located between the prime mover and the gear drive, select the drive based on the brake rating or the highest equivalent power rating, whichever is greater. If the brake is used for holding only and is applied after the motion of the system has come to rest, the brake rating must be less than 200% of the catalog rating, refer the application to Factory. Also refer to Factory all applications in which the brake is located on the output shaft of the gear drive.

**Oversized Prime Mover** Published service factors do not cover applications that require oversize prime movers for high energy or peak loads. Refer such applications to Factory for selection of suitable drives.

**Speed Variation** Gear drives offered in this Selection Guide are designed to operate with splash lubrication at all speeds for which they are catalogued, provided the appropriate amount of lubricant is present based on the drive mounting position. (Refer to Manual 278-109 for oil quantity associated with each gear drive mounting position). Variation of speed between cataloged speeds, or at speeds falling between cataloged speeds, is permissible.

Different oil levels are necessary for various drive sizes, speeds and ratios. Consequently, to operate an existing drive at different speeds from those shown on the nameplate, full application and nameplate information must be referred to Falk for review of the lubrication system.

**Lubrication of Sizes 1133 to 1600** These sizes are furnished filled with a quantity of oil. Quantity of oil furnished is based on the customer identified drive mounting position stated at the time of order. Standard drive mounting positions are shown on Pages 14-19 of this selection guide. Standard oil furnished with the gear drive is a petroleum based lubricant conforming to AGMA Viscosity Grade 7C, ISO Viscosity Grade 460, and no further lubrication of the gear drive is required upon start-up unless otherwise specified.

**Lubrication of Sizes 1700 to 11000** These sizes are furnished without oil. Customer oil fill is required. These sizes are furnished with oil fill plug, oil drain plug, and vent plug. Lubricant quantity lubricant specifications, location of plugs, and recommended oil change frequency are stated in the Installation & Maintenance Guide 278-109.

For Quadrive primaries, refer to Manual 378-101 for lubricant recommendations. Refer to Manual 278-109 for secondary lubricant recommendations.

**Effects of Solar Energy** If a drive operates in the sun at ambient temperatures over 100°F (38°C), then special measures must be taken to protect the drive from solar energy. This protection can consist of a canopy over the drive or reflective paint on the drive. If neither is possible, additional cooling may be required, such as shaft fans, electric fans, cooling tubes, or heat exchangers.

**Overhung Loads & Thrust Loads** The overhung load and thrust load ratings published in this selection guide are based on a service factor of unity and a combination of the most unfavorable conditions of rotation, speed, direction of applied load and drive loading. If the calculated load exceeds the published value, or if an overhung load and thrust load are applied simultaneously to a shaft, refer complete application information to Factory.

# How to Select and Order

## Quick Selection Method

1. Determine Service Factor — Pages 10 and 11.
2. Determine Required Input Horsepower — Calculate the equivalent hp by multiplying the motor hp by the Service Factor.
3. Determine Driver Output Speed and Ratio.
4. Select Drive Type and Size — Refer to Pages 14 through 19 and select the desired drive configuration. Then refer to Pages 22 through 27 (Single Reduction), Pages 52 through 57 (Double Reduction, Worm-Worm), or Pages 82 through 85 (Double Reduction, Helical Worm) and select the drive size. Locate the table containing required ratio, low speed shaft rpm and select the drive size with a mechanical rating equal to or exceeding the equivalent hp requirement.
5. Check Overhung Load — Refer to Tables on Page 13 that provide the overhung load capacities of the gear drives. If an overhung load is present (input or output), calculate the value of the load per instructions on Page 12. Sprockets or other power takeoff devices mounted on the input or output shaft of the gear drive should be sized and positioned so the overhung load capacities are not exceeded. If applied overhung loads exceed the capacity of the initial gear drive selected, a larger gear drive with adequate capacity must be selected.
6. Check External Thrust Load — Allowable thrust loads are provided on Page 13. If thrust and overhung loads are provided simultaneously, or if loads exceed allowable thrust capacities, consult Factory.
7. Check Gear Drive Dimensions — Pages 28 through 49 (Single Reduction), Pages 58 through 79 (Double Reduction, Worm-Worm), or Pages 86 through 115 (Double Reduction, Helical Worm).

## Example

Application: Belt conveyor, heavy duty, head shaft speed is approximately 58 rpm, gear drive is to be flange mounted with hollow input shaft.

Duty Cycle: 16 hours per day.

Driver: 2 hp electric motor, 1750 rpm.

Output: 3" pitch diameter sprocket with a 2:1 chain drive.  
Sprocket is mounted 1.5" from drive seal cage.

1. Service Factor from Page 10 is 1.50
2. Motor Horsepower is .5 hp
3. The head shaft speed must be multiplied by the chain drive ratio to obtain the gear drive output rpm (58 rpm x 2 = 116 rpm).
4. From Page 15, the desired configuration is a Type WOM. From Page 23, in the 1.50 Service Factor Table, the correct selection is a Size 1154, 15:1 ratio drive.
5. Overhung Load Check — The allowable overhung loads are listed in the table on Page 11. The output shaft allowable OHL is 517 lbs. The actual output shaft OHL must be calculated using the following formula:  
$$\frac{126,000 \times .5 \times .619 \times 1.00 \times 1.56}{3.00 \times .774 \times 116} = 226 \text{ lbs}$$

The actual OHL of 226 lbs is less than the allowable of 517 lbs and therefore is acceptable.
6. Check External Thrust Load Capacity on Page 13. For this example there is no external thrust.
7. Check Gear Drive Dimensions on Page 32.



# Drive Nomenclature

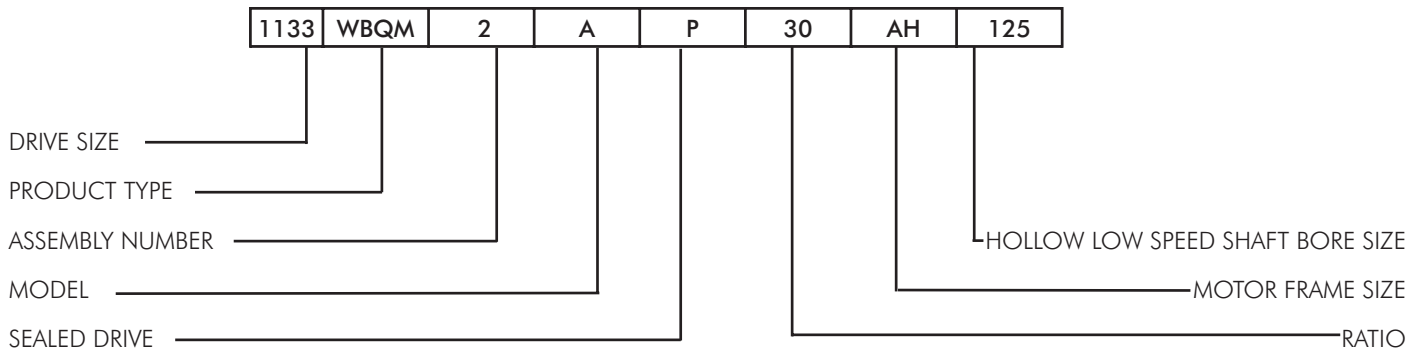

## Drive Size (Shaft Centers)

1133 = 1.33	1262 = 2.62	1525 = 5.25
1154 = 1.54	1300 = 3.00	1600 = 6.00
1175 = 1.75	1325 = 3.25	1700 = 7.00
1206 = 2.06	1326 = 3.26	1800 = 8.00
1238 = 2.38	1425 = 4.25	11000 = 10.00

## Product Type \*

Expressed 2 to 5 letters, including Primary Type, Output Shaft, and Motor Flange, as required.

- WB — Basic drive without Feet (Single Reduction)
- WU — Worm Under (Horizontal LSS)
- WO — Worm Over (Horizontal LSS)
- WX — Vertical Low Speed Shaft
- WJ — Vertical High Speed Shaft (Horizontal LSS)
- WL — Flange Mounted drive
- WR — Extended Output Shaft

## Primary/Type

- H — Helical drives (Double Reduction)
- W — Worm drives (Double Reduction)

## Output Shaft

- Q — Hollow Low Speed Shaft

## Motor Flange

- F — Flange Mounted Electric Motor with Coupling
- M — Flange Mounted Electric Motor without Coupling (Hollow Input Shaft)

## Assembly Number

See Individual Dimension Pages

## Model

- A, B, C, etc.
- S — Modified or Special

## Sealed Drive

- P — Sealed Drive with Pressure Compensation System & Synthetic Lube.
- — Standard Drive (Not Sealed)

## Ratio

Nominal Ratio Expressed 1 to 4 digits, as required

## Motor Frame Size

NEMA Frame Sizes

- AH — 48C
- AA — 56C
- AB — 140TC
- AC — 180TC
- AD — 210TC
- AE — 250TC

IEC Frame Sizes

- GA — 63D
- GB — 71D
- GD — 80D
- GF — 90D
- GH — 100LD
- GK — 112D
- GM — 132D

## Hollow Low Speed Shaft Bore Size

For Sizes 1133-1525, Output Shaft= "Q" Drives Only (Decimal Omitted)

(See Page 5 for footnotes.)

# Service Factors

## Service Factors

A gear drive is rated to a specific application by the use of Service Factor. Each application has its conditions and operating requirements. These have been analyzed and catalogued. Numerical values, based on field experience, have been assigned to these classifications for intermittent service of 3 to 10 hours per day and for service over 10 hours per day and also for the type of prime mover. . . electric motor or engine. Values for most applications are listed by Application on Page 11, Table 3 and by Industry at right, Table 2. Refer unlisted applications to Factory.

Since most industrial applications are electric motor driven, Service Factors are based on the use of electric motors. These factors can be easily converted to engine-drive factors as outlined in Table 1 below.

Service Factors are based on the assumption that the system is free of dynamic vibrations, as explained in the Basic Information section, and that maximum momentary or starting loads do not exceed 200% of the rated load. Refer applications subject to repetitive shocks and applications where exceedingly high energy load must be absorbed, as when stalling, to Factory for special considerations.

## Occasional & Intermittent Service or Engine Driven Applications

Engine driven applications and applications operating up to 3 hours per day, continuously or intermittently, require adjusted Service Factors. Determine normal Service Factor for the application from the 3 to 10 hours per day column in Tables 2 or 3. Next, in the first column of Table 1 below, find this same Service Factor in bold face type. Then, to the right, under the desired hours of service and prime mover, locate the converted Service Factor.

For example, from Table 3, the Service Factor is 1.25 for a uniformly loaded belt conveyor. From Table 1, for the same application the following are the Service Factors for various conditions.

1. Engine driven (multi-cylinder): 3 to 10 hours per day, use 1.50.
2. Engine driven (multi-cylinder): over 10 hours per day, use 1.75.
3. Motor driven (electric): up to 3 hours intermittently, use 1.00.

**Table 1 — Service Factor Conversions**

Table 2 or 3 3 to 10 Hour Service Factor	3 to 10 Hours per Day	Over 10 Hours per Day	Intermittent — Up to 3 Hours per Day †	
	Multi-Cyl. Engine ‡	Multi-Cyl. Engine ‡	Motor	Multi-Cyl. Engine ‡
<b>1.00</b>	1.25	1.50	1.00	1.00
<b>1.25</b>	1.50	1.75	1.00	1.25
<b>1.50</b>	1.75	2.00	1.25	1.50
<b>1.75</b>	2.00	2.25	1.50	1.75
<b>2.00</b>	2.25	2.50	1.75	2.00

† For applications operating one half hour or less per day and applications driven by single cylinder engines, refer to Factory.

‡ These service factors are based on the assumption that the system is free from serious critical and torsional vibrations and that maximum momentary or starting loads do not exceed 200% of the normal load.

★ Service Factors for paper mill applications are applied to the nameplate rating of the electric drive motor at the motor rated base speed and are consistent with those shown in TAPPI standards.

◆ Anti-friction bearings only.

● A service factor of 1.00 may be applied at base speed of a super calender operating over a speed range of part constant hp and part constant torque where the constant hp speed range is greater than 1.5 to 1. A service factor of 1.25 is applicable to super calenders operating at constant torque over the entire speed range or where the constant hp speed range is less than 1.5 to 1.

**Table 2 — Service Factors Listed by Industry**

(For electric motor, steam turbine or hydraulic motor drives . . . recommendations are MINIMUM and normal conditions are assumed.)

Industry	Service		Industry	3 to 10 Hour	Over 10 Hour
	3 to 10 Hour	Over 10 Hour			
<b>BOTTLING AND BREWING</b>			Embosser . . . . .	1.25	
Bottling Machinery . . . . .	1.00	1.25	Extruder . . . . .		1.50
Brew Kettles, Continuous Duty . . . . .	1.00	1.25	<b>Fourdrinier Rolls—</b>		
Can Filling machines . . . . .	1.00	1.25	<b>Lumpbreaker, Wire Turning,</b>		
Cookers—Continuous Duty . . . . .	1.00	1.25	<b>Dandy &amp; Return Rolls . . . . .</b>	1.25	
Mash Tubs—Continuous Duty . . . . .	1.00	1.25	Jordan . . . . .	1.50	
Scale Hoppers—Frequent Starts . . . . .	1.25	1.50	Kiln Drive . . . . .	1.50	
<b>CLAY WORKING INDUSTRY</b>			Mt. Hope & Paper Rolls . . . . .	1.25	
Brick Press . . . . .	1.75	2.00	Platier . . . . .	1.50	
Briquette Machines . . . . .	1.75	2.00	Presses (Felt & Suction) . . . . .	1.25	
Clay Working Machinery . . . . .	1.25	1.50	Pulper (Continuous) . . . . .	1.50	
Pug Mills . . . . .	1.25	1.50	Repulper (Heavy Shock) . . . . .	1.75	
			Reel (Surface Type) . . . . .	1.25	
			See Screens		
<b>DISTILLING</b>			Chip & Rotary . . . . .	1.50	
<b>DREDGES</b>			Vibrating . . . . .	1.75	
Cable Reels, Conveyors . . . . .	1.25	1.50	Size Press . . . . .	1.25	
Cutter Head, Jig Drives & Pumps . . . . .	1.75	2.00	Super Calenders ● . . . . .	1.25	
Maneuvering Winches . . . . .	1.25	1.50	Thickener & Washer		
Screen Drives . . . . .	1.50	1.75	AC Motor . . . . .	1.50	
Stackers, Utility Winches . . . . .	1.25	1.50	DC Motor . . . . .	1.25	
<b>FOOD INDUSTRY</b>			Vacuum Pumps . . . . .	1.50	
Beet Slicers . . . . .	1.25	1.50	Wind & Unwind Stand . . . . .	1.00	
Bottling, Can Filling Machine . . . . .	1.00	1.25	Winders (Surface Type) . . . . .	1.25	
Cereal Cookers . . . . .	1.00	1.25	◆ Yankee Dryers . . . . .	1.25	
Dough Mixers, Meat Grinders . . . . .	1.25	1.50	<b>PLASTIC INDUSTRY</b>		
<b>LUMBER INDUSTRY</b>			Batch Drop Mill, 2 smooth rolls . . . . .	1.50	1.50
Barkers—Spindle Feed . . . . .	1.25	1.50	Calenders . . . . .	1.50	1.50
Barkers—Main Drive . . . . .	1.75	1.75	Compounding Mills . . . . .	1.25	1.25
Carriage Drive . . . . .	Refer to Factory		Continuous Feed, Holding &		
<u>Conveyors</u>			Blend Mill . . . . .	1.25	1.25
Burner . . . . .	1.25	1.50	Extruders . . . . .	1.50	1.50
Main or Heavy Duty . . . . .	1.50	1.50	Variable Speed Drive . . . . .	1.50	1.50
Main Log . . . . .	1.75	2.00	Fixed Speed Drive . . . . .	1.50	1.50
Re-Saw Merry-Go-Round . . . . .	1.25	1.50	<u>Intensive Internal Mixers</u>		
Slab . . . . .	1.75	2.00	Batch Mixers . . . . .	1.50	1.50
Transfer . . . . .	1.25	1.50	Continuous Mixers . . . . .	1.50	1.50
Chains—Floor . . . . .	1.50	1.50	<b>RUBBER INDUSTRY</b>		
Chains—Green . . . . .	1.50	1.75	Batch Drop Mill, 2 smooth rolls . . . . .	1.50	1.50
Cut-Off Saws—Chain & Drag . . . . .	1.50	1.75	Calenders . . . . .	1.50	1.50
Debarking Drums . . . . .	1.75	2.00	Cracker, 2 corrugated rolls . . . . .	1.75	1.75
Feeds—Edger . . . . .	1.25	1.50	Cracker Warmer—2 roll,		
Feeds—Gang . . . . .	1.50	1.50	1 corrugated roll . . . . .	1.50	1.50
Feeds—Trimmer . . . . .	1.25	1.50	Extruders		
Log Deck . . . . .	1.50	1.50	Continuous Screw Operation . . . . .	1.50	1.50
Log Hauls—Incline, Well Type . . . . .	1.50	1.50	Intermittent Screw Operation . . . . .	1.50	1.50
Log Turning Devices . . . . .	1.50	1.50	Holding, Feed & Blend Mill—2 Roll	1.25	1.25
Planer Feed . . . . .	1.25	1.50	Intensive Internal Mixers		
Planer Tilting Hoists . . . . .	1.50	1.50	Batch Mixers . . . . .	1.50	1.50
Rolls—Live—Off Bearing—Roll Cases . . . . .	1.50	1.50	Continuous Mixers . . . . .	1.50	1.50
Sorting Table, Tipple Hoist . . . . .	1.25	1.50	Mixing Mill—2 smooth rolls		
Transfers—Chain & Craneway . . . . .	1.50	1.75	(if corrugated rolls are used, use		
Tray Drives . . . . .	1.25	1.50	Cracker Warmer service factors)	1.50	1.50
Veneer Lathe Drives . . . . .	Refer to Factory		Refiner—2 roll . . . . .	1.50	1.50
<b>OIL INDUSTRY</b>			<b>SEWAGE DISPOSAL</b>		
Chillers . . . . .	1.25	1.50	Bar Screens . . . . .	1.00	1.25
Oil Well Pumping . . . . .	Refer to Factory		Chemical Feeders . . . . .	1.00	1.25
Paraffin Filter Press . . . . .	1.25	1.50	Collectors . . . . .	1.00	1.25
Rotary Kilns . . . . .	1.25	1.50	Dewatering Screens . . . . .	1.25	1.50
<b>PAPER MILLS ★</b>			Scum Breakers . . . . .	1.25	1.50
Agitator (Mixer) . . . . .	1.50	1.50	Slow or Rapid Mixers . . . . .	1.25	1.50
Agitator for Pure Liquids . . . . .	1.25	1.25	Thickeners . . . . .	1.25	1.50
Barking Drums, Barkers—Mech. . . . .	1.75	1.75	Vacuum Filters . . . . .	1.25	1.50
Beater . . . . .	1.50	1.50	<b>SUGAR INDUSTRY</b>		
Breaker Stack . . . . .	1.25	1.25	Cane Knives, Crushers . . . . .	1.50	1.50
◆ Calender . . . . .	1.25	1.25	Mills (low speed end) . . . . .	1.50	1.50
Chipper . . . . .	1.75	1.75	<b>TEXTILE INDUSTRY</b>		
Chip Feeder . . . . .	1.50	1.50	Batchers, Calenders . . . . .	1.25	1.50
Coating Rolls . . . . .	1.25	1.25	Card Machines . . . . .	1.25	1.50
<u>Conveyors</u>			Dry Cans, Dryers . . . . .	1.25	1.50
Chip, Bark, Chemical . . . . .	1.25	1.25	Dyeing Machinery . . . . .	1.25	1.50
Log (incl. Slab) . . . . .	1.75	1.75	Knitting Machinery . . . . .	Refer to Factory	
Couch Rolls . . . . .	1.25	1.25	Looms, Mangles, Nappers, Pads . . . . .	1.25	1.50
Cutter . . . . .	2.00	2.00	Range Drives . . . . .	Refer to Factory	
Cylinder molds . . . . .	1.25	1.25	Slashers, Soapers, Spinners, Tenter		
◆ Dryers —			Frames, Washers, Winders . . . . .	1.25	1.50
Paper Mach. & Conveyor Type . . . . .	1.25	1.25	<b>WINDLASS</b>	Refer to Factory	

### Table 3 — Service Factors Listed by Application

(For electric motor, steam turbine or hydraulic motor drives . . . recommendations are MINIMUM and normal conditions are assumed.)

Application	Service		Application	Service		Application	Service		Application	Service	
	3 to 10 Hour	Over 10 Hour		3 to 10 Hour	Over 10 Hour		3 to 10 Hour	Over 10 Hour		3 to 10 Hour	Over 10 Hour
<b>AGITATORS</b>			<b>▲ CONVEYORS—Uniformly loaded or Fed:</b>			<b>▲ HOISTS</b>			<b>PUMPS</b>		
Pure Liquids . . . . .	1.00	1.25	Apron, Bucket, Assembly, Belt, Chain, Flight, Oven, Screw . . .	1.00	1.25	Heavy Duty . . . . .	1.75	2.00	Centrifugal . . . . .	1.00	1.25
Liquids & Solids . . . . .	1.25	1.50				Medium Duty . . . . .	1.25	1.50	Proportioning . . . . .	1.25	1.50
Liquids-Variable Density . . . . .	1.25	1.50	<b>▲ CONVEYORS—Heavy Duty, Not Uniformly Fed</b>			Skip Hoist . . . . .	1.25	1.50	Reciprocating		
<b>APRON CONVEYORS</b>			Apron, Assembly, Belt, Bucket, Chain, Flight, Oven, Screw . . .	1.25	1.50	<b>INDUCED DRAFT FANS</b>	1.25	1.50	Single Act., 3 or more Cyl. . . . .	1.25	1.50
Uniformly Loaded or Fed . . . . .	1.00	1.25	<b>CONVEYORS—Severe Duty</b>			See Mills, Rotary			Double Act., 2 or more Cyl. . . . .	1.25	1.50
Heavy Duty . . . . .	1.25	1.50	Live Roll . . . . .	Refer to Factory		<b>LAUNDRY WASHERS</b>	1.25	1.50	Single Act., 1 or 2 Cyl. . . . .	Refer to Factory	
<b>APRON FEEDERS</b>	1.25	1.50	Reciprocating Shaker . . . . .	1.50	1.75	<b>LAUNDRY TUMBLERS</b>	1.25	1.50	Double Acting, 1 Cyl. . . . .	Refer to Factory	
<b>ASSEMBLY CONVEYORS</b>			<b>COOKERS (Brewing &amp; Distilling), (food)</b>	1.00	1.25	<b>LINE SHAFTS</b>			Rotary: Gear, Lobe, Vane . . . . .	1.00	1.25
Uniformly Loaded or Fed . . . . .	1.00	1.25	<b>COOLING TOWER FANS</b>	Refer to Factory		Driving Processing Equipment . . . . .	1.25	1.50	<b>PUNCH PRESSES (Gear Driven)</b>	1.50	1.75
Heavy Duty . . . . .	1.25	1.50	<b>▲ CRANES</b>			Other Line Shafts, Light . . . . .	1.00	1.25	<b>RECIPROCATING</b>		
<b>BALL MILLS</b>	See Mills, Rotary		Dry Dock Cranes, Main Hoist, Bridge and Trolley Travel . . . . .	Refer to Factory		<b>LIVE ROLL CONVEYORS</b>	Refer to Factory		Conveyors & Feeders . . . . .	1.75	2.00
<b>BARGE HAUL PULLERS</b>	1.50	1.75	<b>CRUSHERS</b>			<b>LOBE BLOWERS OR COMPRESSORS</b>	1.25	1.50	<b>RECIPROCATING COMPRESSORS</b>		
<b>BARKING</b>			Ore or Stone . . . . .	1.50	1.75	<b>LOG HAULS (Lumber)</b>			Multi-Cylinder . . . . .	1.25	1.75
Drums (Coupling Connected) . . . . .	1.75		Sugar . . . . .	1.50	1.50	Incline-well Type . . . . .	1.50	1.50	Single Cylinder . . . . .	1.50	1.75
Mechanical . . . . .	1.75		<b>DEWATERING SCREENS (Sewage)</b>	1.25	1.50	<b>LOOMS (Textile)</b>	1.25	1.50	<b>ROD MILLS</b>	See Mills, Rotary	
<b>BAR SCREENS (Sewage)</b>	1.00	1.25	<b>DISC FEEDERS</b>	1.00	1.25	<b>LUMBER INDUSTRY</b>	See Table 3		<b>ROTARY</b>		
<b>BATCHERS (Textile)</b>	1.25	1.50	<b>DISTILLING</b>	See Table 3		<b>MACHINE TOOLS</b>			Pumps . . . . .	1.00	1.25
<b>BELT CONVEYORS</b>			<b>DOUBLE ACTING PUMPS</b>			Auxiliary Drives . . . . .	1.00	1.25	Screens (Sand or Gravel) . . . . .	1.25	1.50
Uniformly Loaded or Fed . . . . .	1.00	1.25	2 or more Cylinders . . . . .	1.25	1.50	Bending Rolls . . . . .	1.25	1.50	<b>RUBBER &amp; PLASTICS INDUSTRIES</b>	See Table 3	
Heavy Duty . . . . .	1.25	1.50	Single Cylinder . . . . .	Refer to Factory		Main Drives . . . . .	1.25	1.50	<b>SAND MULLERS</b>	1.25	1.50
<b>BELT FEEDERS</b>	1.25	1.50	<b>DOUGH MIXER (Food)</b>	1.25	1.50	Notching Press (Belted) . . . . .	Refer to Factory		<b>SCREENS</b>		
<b>BENDING ROLLS (Machine)</b>	1.25	1.50	<b>DRAW BENCH (Metal Mills)</b>	1.25	1.50	Plate Planers . . . . .	1.50	1.75	Air Washing . . . . .	1.00	1.25
<b>BLOWERS</b>			Carriage & Main Drive . . . . .	1.25	1.50	Punch Press (Geared) . . . . .	1.50	1.75	Rotary—Sand or Gravel . . . . .	1.25	1.50
Centrifugal . . . . .	1.00	1.25	<b>DREDGES</b>	See Table 3		Tapping machines . . . . .	1.50	1.75	Traveling Water Intake . . . . .	1.00	1.25
Lobe . . . . .	1.25	1.50	<b>DRY DOCK CRANES</b>	*		<b>MANGLE (Textile)</b>	1.25	1.50	<b>SCREW CONVEYORS</b>		
Vane . . . . .	1.00	1.25	<b>DRYERS &amp; COOLERS (Mills, Rotary)</b>	1.50		<b>MASH TUBS (Brewing &amp; Distilling)</b>	1.00	1.25	Uniform . . . . .	1.00	1.25
<b>BOTTLING MACHINERY</b>	1.00	1.25	<b>DYEING MACHINERY (Textile)</b>	1.25	1.50	<b>MEAT GRINDERS (Food)</b>	1.00	1.50	Heavy Duty or Feeder . . . . .	1.25	1.50
<b>BREWING</b>	See Table 3		<b>ELEVATORS</b>			<b>METAL MILLS</b>			<b>SCUM BREAKERS (Sewage)</b>	1.25	1.50
<b>BRICK PRESS (Clay Working)</b>	1.75	2.00	Bucket-Uniform Load . . . . .	1.00	1.25	Draw Bench Carriages & Main Drives . . . . .	1.25	1.50	<b>SEWAGE DISPOSAL</b>	See Table 3	
<b>BRIQUETTE MACHINES (Clay Working)</b>	1.75	2.00	Bucket-Heavy Duty . . . . .	1.25	1.50	Pinch, Dryer & Scrubber . . . . .			<b>SHAKER CONVEYORS</b>	1.50	1.75
<b>BUCKET</b>			Bucket-Continuous . . . . .	1.00	1.00	Rolls, Reversing . . . . .	Refer to Factory		<b>SHEETERS (Rubber)</b>	1.50	
Conveyors Uniform . . . . .	1.00	1.25	Centrifugal Discharge . . . . .	1.25	1.25	Slitters . . . . .	1.25	1.50	<b>SINGLE ACTING PUMP</b>		
Conveyors Heavy Duty . . . . .	1.25	1.50	▲ Escalators . . . . .	Not Approved		Table Conveyors, Non-Reversing Group Drives . . . . .	1.50	1.50	1 or 2 Cylinders . . . . .	Refer to Factory	
Elevators Continuous . . . . .	1.00	1.25	▲ Freight . . . . .	Not Approved		Non-Reversing Individual Drives . . . . .	2.00	2.00	3 or more Cylinders . . . . .	1.25	1.50
Elevators Uniform . . . . .	1.00	1.25	Gravity Discharge . . . . .	1.00	1.25	Reversing . . . . .	Refer to Factory		<b>▲ SKI TOWS &amp; LIFTS</b>	Not Approved	
Elevators Heavy Duty . . . . .	1.25	1.50	▲ Man Lifts, Passenger . . . . .	Not Approved		Wire Drawing & Flattening Machines . . . . .	1.25	1.50	<b>▲ SKIP HOIST</b>	1.25	1.50
<b>CALENDERS</b>			<b>EXTRUDERS (Plastic &amp; Rubber)</b>	See Table 3		Wire Winding Machines . . . . .	1.25	1.50	<b>SLAB PUSHERS</b>	1.25	1.50
Rubber and Plastic . . . . .	See Table 3		<b>FANS</b>			<b>MILLS, ROTARY</b>			<b>SLITTERS (Metal)</b>	1.25	1.50
Textile . . . . .	1.25	1.50	Centrifugal . . . . .	1.00	1.25	Ball and Rod Mills with Spur Ring Gear . . . . .	1.75		<b>SLUDGE COLLECTORS (Sewage)</b>	1.00	1.25
<b>CANE KNIVES</b>	1.50	1.50	Cooling Towers . . . . .	Refer to Factory		with Helical Ring Gear . . . . .	1.50		<b>SOAPERS (Textile)</b>	1.25	1.50
<b>CAN FILLING MACHINES</b>	1.00	1.25	Forced Draft . . . . .	1.25		Direct Connected . . . . .	2.00		<b>SPINNERS (Textile)</b>	1.25	1.50
<b>CARD MACHINES (Textile)</b>	1.25	1.50	Induced Draft . . . . .	1.25	1.50	Cement Kilns, Dryers & Coolers, Pebble, Plain & Wedge Bar Mills . . . . .	1.50	1.75	<b>STEERING GEARS</b>	Refer to Factory	
<b>CAR DUMPERS</b>	1.50	1.75	Large (Mine, etc.) . . . . .	1.25	1.50	Tumbling Barrels . . . . .	1.50		<b>STOKERS</b>	1.00	1.25
<b>CAR PULLERS</b>	1.25	1.50	Large Industrial . . . . .	1.25	1.50	<b>MIXER (Also see Agitators)</b>			<b>STONE CRUSHERS</b>	1.50	1.75
<b>CEMENT KILNS</b>	See Mills, Rotary		Light (Small Diameter) . . . . .	1.00	1.25	Concrete, Cont. & Int. . . . .	1.25	1.50	<b>SUGAR INDUSTRY</b>	See Table 3	
<b>CENTRIFUGAL</b>			<b>FEEDERS</b>			Constant Density . . . . .	1.00	1.50	<b>TABLE CONVEYORS (Non-Reversing)</b>		
Blowers, Compressors, Discharge Elevators, Fans or Pumps . . . . .	1.00	1.25	Apron, Belt . . . . .	1.25	1.50	Variable Density . . . . .	1.25	1.50	Group Drives . . . . .	1.25	1.50
<b>CHAIN CONVEYORS</b>			Disc . . . . .	1.00	1.25	<b>NAPPERS (Textile)</b>	1.25	1.50	Individual Drives . . . . .	1.50	1.75
Uniformly Loaded or Fed . . . . .	1.00	1.25	Reciprocating . . . . .	1.75	2.00	<b>OIL INDUSTRY</b>	See Table 3		Reversing . . . . .	Refer to Factory	
Heavy Duty . . . . .	1.25	1.50	Screw . . . . .	1.25	1.50	<b>ORE CRUSHERS</b>	1.50	2.00	<b>TENTER FRAMES (Textile)</b>	1.25	1.50
<b>CHEMICAL FEEDERS (Sewage)</b>	1.00	1.25	<b>FLIGHT CONVEYORS</b>			<b>OVEN CONVEYORS</b>			<b>TEXTILE INDUSTRY</b>	See Table 3	
<b>CLARIFIERS</b>	1.00	1.25	Uniform . . . . .	1.00	1.25	Uniform . . . . .	1.00	1.25	<b>THICKENERS (Sewage)</b>	1.25	1.50
<b>CLASSIFIERS</b>	1.25	1.50	Heavy . . . . .	1.25	1.50	Heavy Duty . . . . .	1.25	1.50	<b>TUMBLING BARRELS</b>	1.50	1.75
<b>CLAY WORKING</b>	See Table 3		<b>FOOD INDUSTRY</b>	See Table 3		<b>PAPER MILLS</b>	See Table 3		<b>VACUUM FILTERS (Sewage)</b>	1.25	1.50
<b>COLLECTORS (Sewage)</b>	1.00	1.25	<b>GENERATORS (Not Welding)</b>	1.00	1.25	<b>▲ PASSENGER ELEVATORS</b>	Not Approved		<b>VANE BLOWERS</b>	1.00	1.25
<b>COMPRESSORS</b>			<b>GRAVITY DISCHARGE ELEVATORS</b>	1.00	1.25	<b>PEBBLE MILLS</b>	1.50		<b>WINCHES (Dredges)</b>	1.25	1.50
Centrifugal . . . . .	1.00	1.25	<b>HAMMER MILLS</b>	1.50	1.75	<b>PLATE PLANERS</b>	1.50	1.75	<b>WINDERS (Textile)</b>	1.25	1.50
Lobe . . . . .	1.25	1.50				<b>PRINTING PRESSES</b>	Refer to Factory		<b>WINDLASS</b>	Refer to Factory	
<b>Reciprocating</b>						<b>PROPORTIONING PUMPS</b>	1.25	1.50	<b>WIRE</b>		
Multi-Cylinder . . . . .	1.25	1.50				<b>PUG MILLS (Clay)</b>	1.25	1.50	Drawing Machines . . . . .	1.25	1.50
Single-Cylinder . . . . .	1.50	1.75				<b>PULLERS (Barge Haul)</b>	1.50	1.75	Winding Machines . . . . .	1.25	1.50
<b>CONCRETE MIXERS</b>											
Continuous . . . . .	1.25	1.50									
Intermittent . . . . .	1.25	1.50									

▲ Selection of Rexnord products for applications whose primary purpose is the transportation of people is not approved. This includes such applications as freight or passenger elevators, escalators, man lifts, work lift platforms and ski tows and ski lifts. If the primary purpose of the application is material conveyance and occasionally people are transported, the Factory warranty may remain in effect provided the design load conditions are not exceeded and certification to the appropriate safety codes and load conditions has been obtained by the system designer or end user from the appropriate enforcement authorities.

■ Contact Rexnord for proper selection of a Falk RAM mixer drive.

# Overhung Load and Thrust Loads

**Overhung Load** — Overhung load is imposed upon a shaft when a pinion, sprocket, or sheave is used as a power take-off. The magnitude of the load varies with the type of take-off and its proximity to the shaft bearing. Calculate the load (including minimum required service factor) and check the result against the tabulated overhung load rating. The overhung load formula below considers the transmitted horsepower without service factor. This is appropriate for applications where starting loads, momentary overloads, and brake capacities do not exceed 200% of drive rating (100% overload). For other conditions, compute the equivalent power by multiplying the transmitted power by the appropriate service factor.

## Overhung Load Formulas:

$$\text{Output OHL} = \frac{126,000 \times \text{motor hp} \times \text{output hp rating} \times F_c \times L_f}{\text{pitch diameter} \times \text{input hp rating} \times \text{output rpm}}$$

$$\text{Input OHL} = \frac{126,000 \times \text{motor hp} \times F_c \times L_f}{\text{pitch diameter} \times \text{input rpm}}$$

Where:

Output hp Rating = from Pages 24 through 27

Input hp Rating = from Pages 22 through 27 (Single Reduction), Pages 52 through 57 (Double Reduction, Worm-Worm), or Pages 82 through 85 (Double Reduction, Helical Worm)

$F_c$  = load connection factor

$L_f$  = load location factor (The input shaft OHL is assumed to be applied at one shaft diameter from the seal cage, ( $L_f=1.0$ ) If the load is applied at a distance greater than one shaft diameter from the seal cage, refer the application to Falk)

The calculated overhung load must be less than or equal to the capacity shown on Page 13.

**Load Location Factor ( $L_f$ )** — The output shaft load location factors are shown below.

## $L_f$ - Load Location Factors for Output Shafts

Distance in inches H	DRIVE SIZE													
	1133	1154	1175	1206	1238	1262	1300	1325	1425	1525	1600	1700	1800	11000
.250	.89	.89												
.375	.93	.93												
.500	.96	.96	.92	.90	...	.89								
.625	1.00	1.00	.94	.93	.90	.91								
.750	1.08	1.08	.97	.95	.91	.93	.92	.89	.86					
.875	1.16	1.16	1.00	.97	.94	.95	.94	.91	.88	.88				
1.000	1.23	1.23	1.06	1.00	.97	.98	.96	.93	.91	.89	.69	.68	.63	
1.125	1.31	1.31	1.13	1.07	1.00	1.00	.98	.95	.92	.91	.89	.72	.71	.65
1.250	1.39	1.39	1.20	1.14	1.03	1.03	1.00	.98	.93	.92	.90	.75	.74	.67
1.375	1.48	1.48	1.28	1.21	1.09	1.08	1.06	1.00	.94	.93	.92	.76	.76	.69
1.500	1.56	1.56	1.35	1.27	1.14	1.12	1.10	1.03	.96	.94	.93	.79	.77	.71
1.625	1.64	1.64	1.42	1.33	1.21	1.16	1.16	1.06	.97	.96	.94	.81	.79	.72
1.750	1.72	1.72	1.49	1.39	1.28	1.22	1.21	1.10	.98	.97	.95	.82	.80	.73
1.875	1.79	1.82	1.56	1.45	1.35	1.27	1.26	1.12	1.00	.99	.96	.84	.82	.75
2.000	...	...	...	1.52	1.45	1.33	1.31	1.16	1.04	1.00	.97	.87	.84	.77
2.250	...	...	...	...	1.64	1.47	1.42	1.25	1.11	1.06	1.00	.91	.88	.80
2.500	...	...	...	...	...	1.64	1.52	1.33	1.18	1.12	1.09	.96	.92	.84
2.750	...	...	...	...	...	...	1.62	1.45	1.25	1.19	1.18	1.00	.96	.87
3.000	...	...	...	...	...	...	1.72	1.59	1.33	1.25	1.27	1.04	1.00	.90
3.250	...	...	...	...	...	...	1.83	1.72	1.41	1.32	1.35	1.08	1.04	.93
3.500	...	...	...	...	...	...	...	...	1.47	1.39	1.43	1.13	1.08	.97
3.750	...	...	...	...	...	...	...	...	1.54	1.45	1.52	1.18	1.12	1.00
4.000	...	...	...	...	...	...	...	...	...	1.52	1.61	1.23	1.16	1.03
4.250	...	...	...	...	...	...	...	...	...	...	1.69	1.28	1.20	1.06
4.500	...	...	...	...	...	...	...	...	...	...	1.79	1.32	1.24	1.10
4.750	...	...	...	...	...	...	...	...	...	...	1.89	1.36	1.28	1.13
5.000	...	...	...	...	...	...	...	...	...	...	1.96	1.40	1.32	1.16
5.750	...	...	...	...	...	...	...	...	...	...	...	...	...	1.26

† Distance is in inches from the L.S. Seal Cage. Interpolate for Load Location Factors at intermediate distances. For example, the load location factor is 1.56 for Size 1262 when distance is 2.375 inches. Consult Falk for distances greater than those shown.

## Load Connection Factor ( $F_c$ )

Type of Connection	Factor
Sprocket or Timing Belt	1.00
Machined Pinion & Gear	1.25
V-Belt	1.50
Flat Belt	2.50
Synchronous (Timing) Belts	1.30

† Refer all multiple chain, sprocket, and pinion mounted applications to Falk for Deflection Analysis.

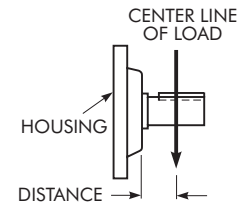

**Locate the centerline of the load** as close to the drive housing as practical to minimize the overhung load and increase the bearing life. The overhung load formula employs the transmitted horsepower, without service factor, providing the overloads starting loads and brake capacities do not exceed the amounts listed in basic information on Page 6.

### Example:

Gear Drive Size = 1325WB2A30, exact ratio of 30.0

Input hp rating = 3.003 hp

Output hp rating = 2.454 hp

Motor = 3.0 hp at 1750 rpm

Low Speed shaft rpm =  $1750 \div 30.0 = 58.3$  rpm

4" diameter sprocket mounted on low speed shaft. Centerline of sprocket overhung load is positioned at 1.125 inches.

Calculate the overhung load as follows:

$$\text{OHL} = \frac{126,000 \times 3.0 \times 2.454 \times 1.00 \times .95}{4 \times 58.3 \times 3.003} = 1258 \text{ lbs}$$

Allowable OHL on Page 13 is 1536 lbs and is satisfactory for this selection.

**Consult Factory for Higher Overhung Load Ratings** — In many cases, overhung load capacity in excess of that published is available. Published ratings are based on a combination of the most unfavorable conditions of rotation, speed, direction of applied load and drive loading. If the actual load should exceed the published capacity, refer full details to Factory.

### Thrust Loads

Output shaft external thrust capacities are shown below. The applied external thrust must be less than or equal to the published capacity. The published thrust capacity is for applications with a pure thrust load only. Combined overhung load and thrust applications should be referred to the Factory.

# Engineering Data

The following overhung load values are based on load located at one shaft diameter from seal cage. Published ratings are based on a combination of the most unfavorable conditions of loading. For higher ratings, refer full data to Factory.

## Single Reduction L.S. Shaft Overhung Load — Pounds

Nominal Ratio	SPEED (rpm)		DRIVE SIZE													
	Input	Approx. Output	1133	1154	1175	1206	1238	1262	1300	1325	1425	1525	1600	1700	1800	11000
5	1750	350	419	517	473	494	1107	1107	1518	1536	2204	2384	3538	6209	7761	11029
	1170	234									2265	2591	3900			
	870	174									2265	2750	3951			
	100	20									2265	2752	3951			
7.5	1750	233	419	517	473	494	1107	1107	1518	1536	2265	2724	3951	6209	7761	11029
	1170	156									2752	2752	2752			
	870	116														
	100	13														
All Other Ratios			419	517	473	494	1107	1107	1518	1536	2265	2752	3951	6209	7761	11029

## Single Reduction H.S. Shaft Overhung Load — Pounds

DRIVE SIZE	1133	1154	1175	1206	1238	1262	1300	1325	1425	1525	1600	1700	1800	11000
H.S. Shaft OHL	75	75	75	75	125	125	150	150	175	300	450	450	450	500

## Single Reduction L.S. Shaft Thrust Load Capacity — Pounds

Nominal Ratio	DRIVE SIZE													
	1133	1154	1175	1206	1238	1262	1300	1325	1425	1525	1600	1700	1800	11000
5	827	794	793	735	1451	1420	1729	1605	1445	1675	3633	4009	4777	6808
7.5	948	949	868	811	1659	1609	1944	1869	1640	2021	3990	4009	4777	6808
10	1070	1056	976	898	1820	1762	2147	2026	1788	2449	3990	4009	4777	6808
15	1144	1144	1144	1099	2091	2069	2459	2490	2319	3033	3990	4009	4777	6808
All Other Ratios	1144	1144	1144	1144	2091	2091	2574	2574	2533	3412	3990	4009	4777	6808

## Double Reduction (Worm-Worm) L.S. Shaft & H.S. Shaft Overhung Load & Thrust Load Capacity — Pounds

DRIVE SIZE	1133	1154	1175	1206	1238	1262	1300	1325	1425	1525	1600	1700	1800	11000
L.S. Shaft OHL (all ratios)	419	517	473	494	1107	1107	1518	1536	2265	2752	3951	6209	7761	11028
H.S. Shaft OHL (all ratios)	75	75	75	75	75	75	75	75	75	125	150	150	175	300
L.S. Shaft Thrust	1144	1144	1144	1144	2091	2091	2574	2574	2533	3412	3990	4009	4777	6808

## Double Reduction & Triple (Helical Worm) Overhung Load & Thrust Load Capacity — Pounds

DRIVE SIZE	1133	1154	1175	1206	1237	1262	1300	1325	1425	1525	1600	1700	1800	11000
L.S. Shaft OHL	419	517	473	494	1107	1039	1518	1464	2265	2752	3723	6209	7761	11028
H.S. Shaft OHL	75	75	75	75	75	75	75	75	150	150	150	175	300	450
LS Shaft Thrust	1144	1144	1144	1144	2091	2091	2574	2574	2533	3412	3990	4009	477	6808

# Selection Guide \*

Drives with Motorized  
Hollow Input Shaft and  
Solid Output Shaft

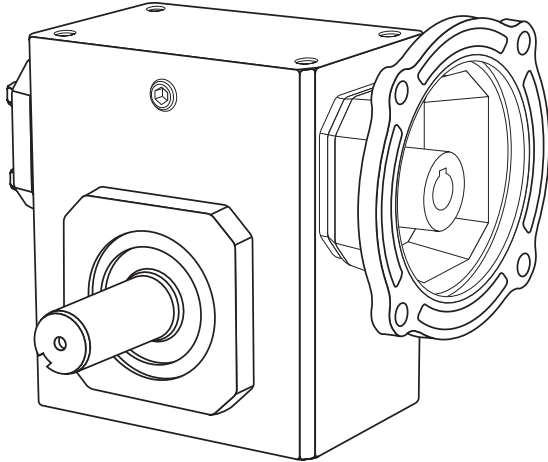

## Single Reduction

Selections — Pages 22 through 27  
Dimensions — Pages 28 through 51

---

## Double Reduction Worm-Worm

Selections — Pages 52 through 57  
Dimensions — Pages 58 through 81

---

## Double Reduction Helical-Worm

Selections — Pages 82 through 85  
Dimensions — Pages 86 through 117

---

Drives with Motorized  
Hollow Input Shaft and  
Hollow Output Shaft

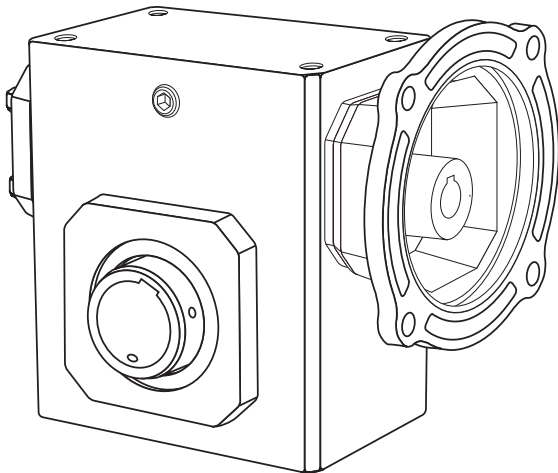

## Single Reduction

Selections — Pages 22 through 27  
Dimensions — Pages 28 through 51

---

## Double Reduction Worm-Worm

Selections — Pages 52 through 57  
Dimensions — Pages 58 through 81

---

## Double Reduction Helical-Worm

Selections — Pages 82 through 85  
Dimensions — Pages 86 through 117

---

(See Page 5 for footnotes.)

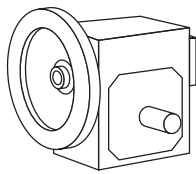

**WBM**

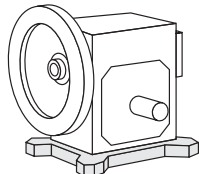

**WOM**

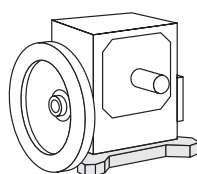

**WUM**

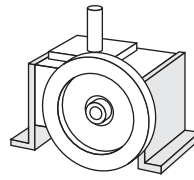

**WXM**

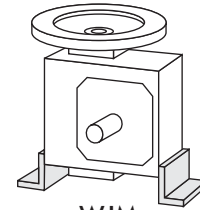

**WJM**

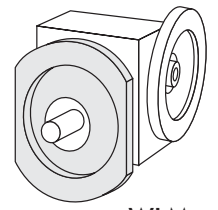

**WLM**

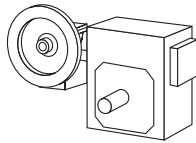

**WBWM**

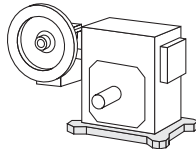

**WOWM**

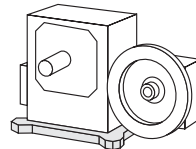

**WUWM**

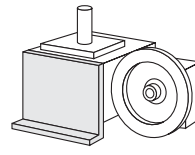

**WXWM**

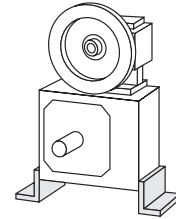

**WJWM**

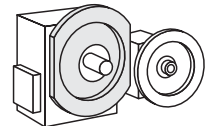

**WLWM**

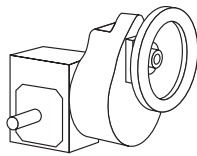

**WBHM**

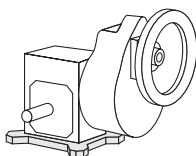

**WOHM**

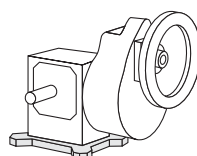

**WUHM**

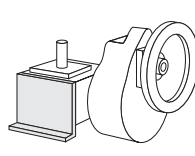

**WXHM**

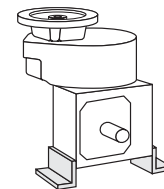

**WJHM**

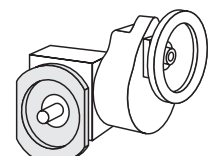

**WLHM**

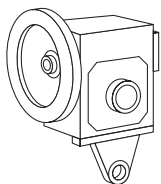

**WBQM**

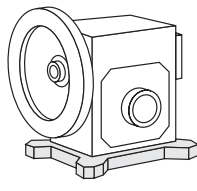

**WOQM**

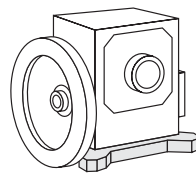

**WUQM**

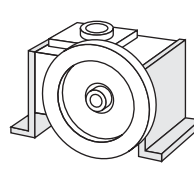

**WXQM**

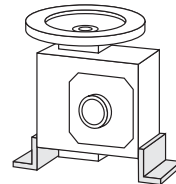

**WJQM**

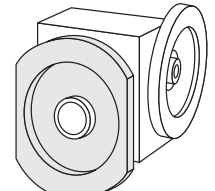

**WLQM**

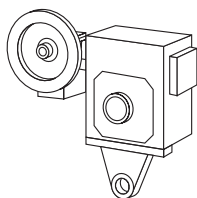

**WBWQM**

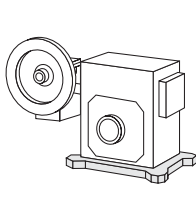

**WOWQM**

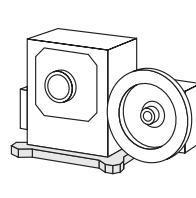

**WUWQM**

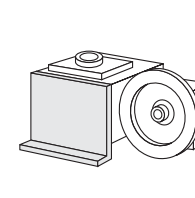

**WXWQM**

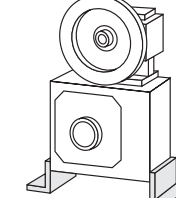

**WJWQM**

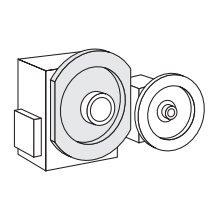

**WLWQM**

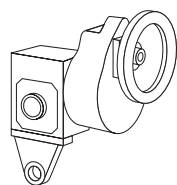

**WBHQM**

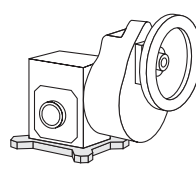

**WOHQM**

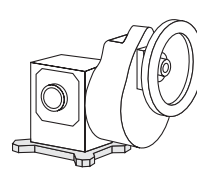

**WUHQM**

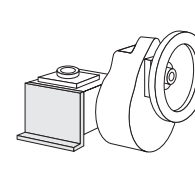

**WXHQM**

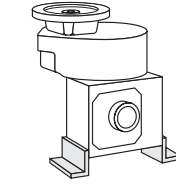

**WJHQM**

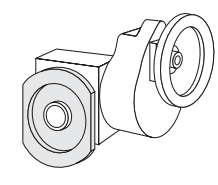

**WLHQM**

---

# Selection Guide \*

Drivers with Solid  
Input Shaft and  
Solid Output Shaft

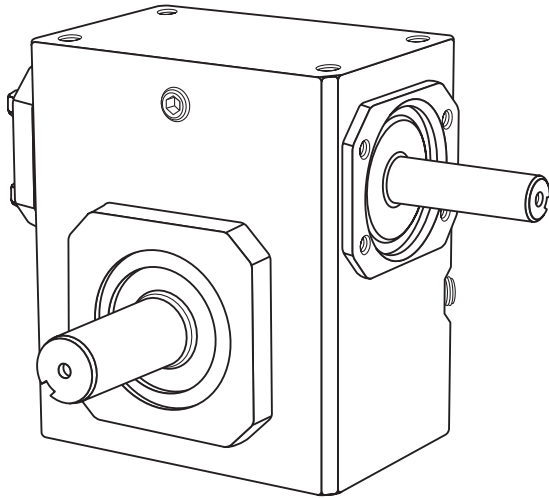

## Single Reduction

Selections — Pages 22 through 27  
Dimensions — Pages 28 through 51

---

## Double Reduction Worm-Worm

Selections — Pages 52 through 57  
Dimensions — Pages 58 through 81

---

## Double Reduction Helical-Worm

Selections — Pages 82 through 85  
Dimensions — Pages 86 through 117

---

---

Drivers with Solid  
Input Shaft and  
Hollow Output Shaft

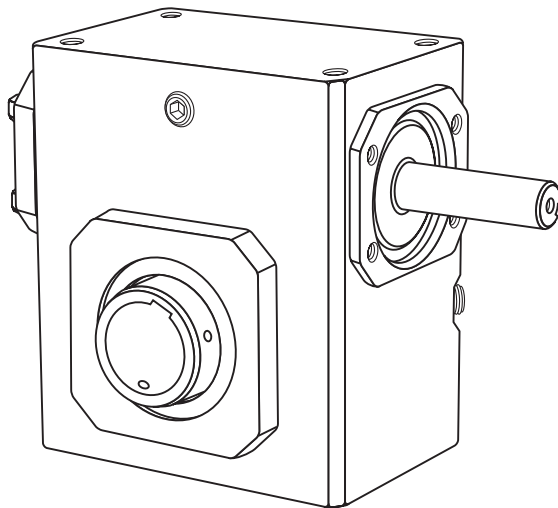

## Single Reduction

Selections — Pages 22 through 27  
Dimensions — Pages 28 through 51

---

## Double Reduction Worm-Worm

Selections — Pages 52 through 57  
Dimensions — Pages 58 through 81

---

## Double Reduction Helical-Worm

Selections — Pages 82 through 85  
Dimensions — Pages 86 through 117

---

(See Page 5 for footnotes.)



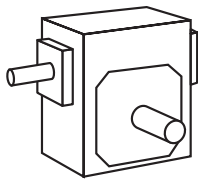

WB

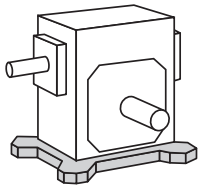

WO

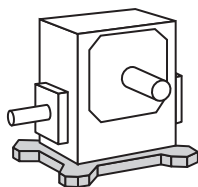

WU

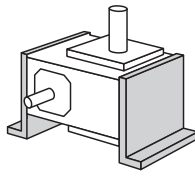

WX

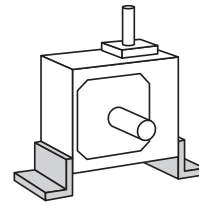

WJ

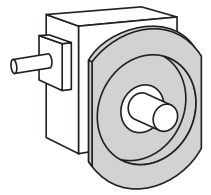

WL

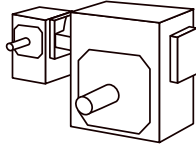

WBW

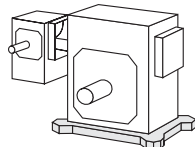

WOW

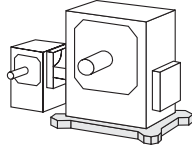

WUW

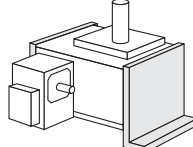

WXW

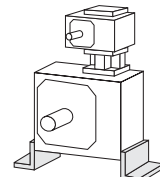

WJW

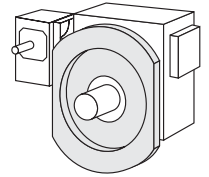

WLW

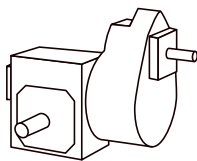

WBH

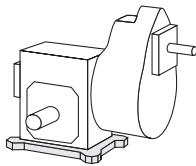

WOH

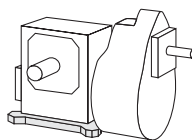

WUH

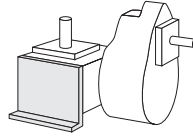

WXH

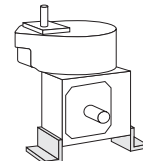

WJH

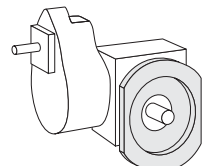

WLH

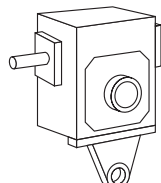

WBQ

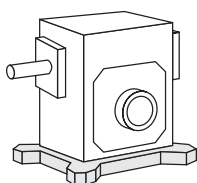

WOQ

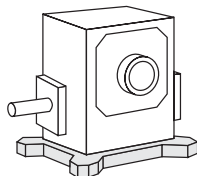

WUQ

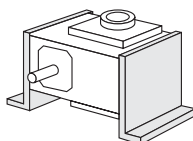

WXQ

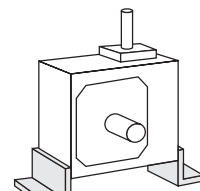

WJQ

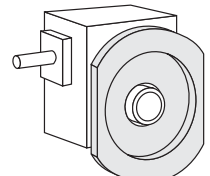

WLQ

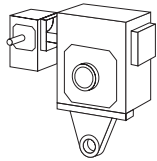

WBWQ

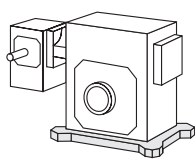

WOWQ

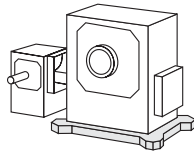

WUWQ

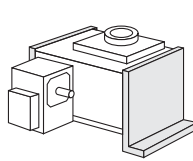

WXWQ

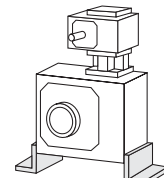

WJWQ

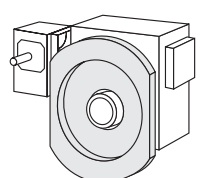

WLWQ

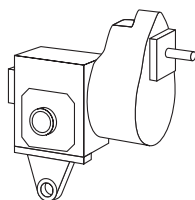

WBHQ

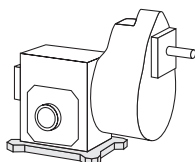

WOHQ

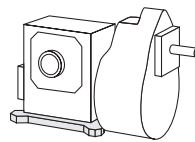

WUHQ

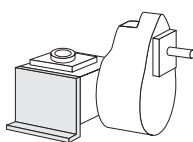

WXHQ

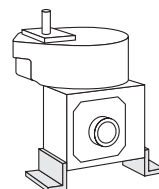

WJHQ

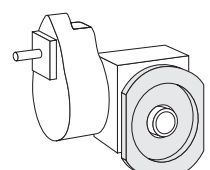

WLHQ

# Selection Guide \*

Drivers with Motorized  
Solid Input Shaft and  
Solid Output Shaft

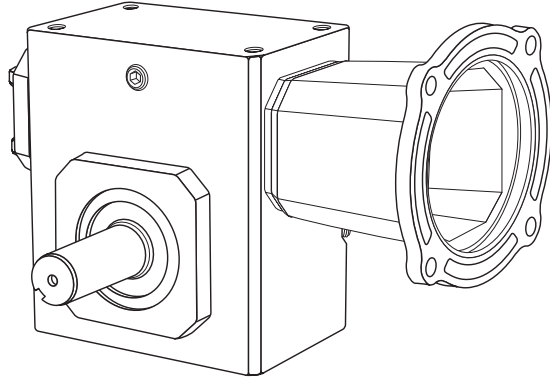

## Single Reduction

Selections — Pages 22 through 27

Dimensions — Pages 28 through 51

---

## Double Reduction Worm-Worm

Selections — Pages 52 through 57

Dimensions — Pages 58 through 81

---

Drivers with Motorized  
Solid Input Shaft and  
Hollow Output Shaft

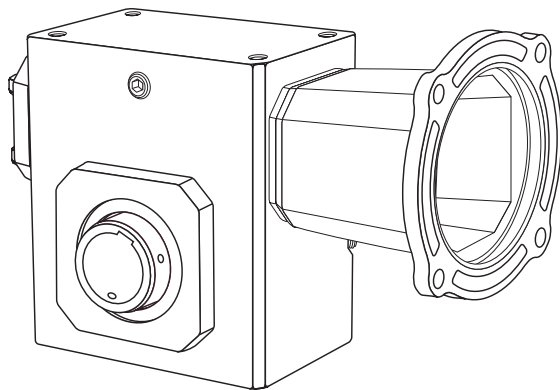

## Single Reduction

Selections — Pages 22 through 27

Dimensions — Pages 28 through 51

---

## Double Reduction Worm-Worm

Selections — Pages 52 through 57

Dimensions — Pages 58 through 81

---

(See Page 5 for footnotes.)

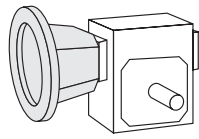

**WBF**

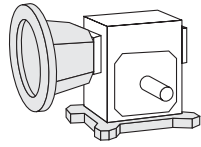

**WOF**

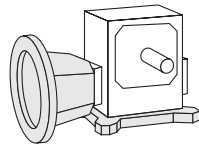

**WUF**

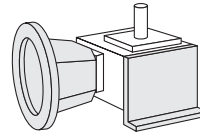

**WXF**

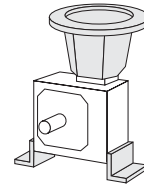

**WJF**

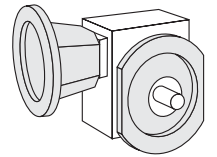

**WLF**

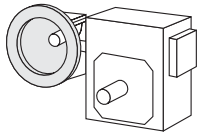

**WBWF**

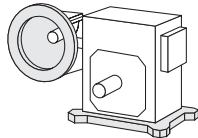

**WOWF**

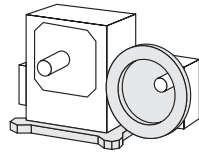

**WUWF**

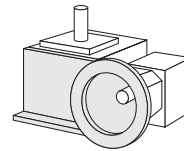

**WXWF**

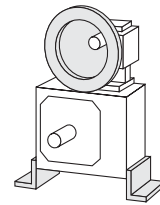

**WJWF**

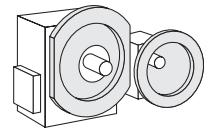

**WLWF**

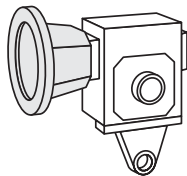

**WBQF**

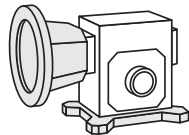

**WOQF**

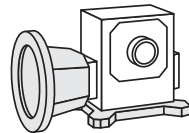

**WUQF**

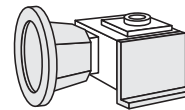

**WXQF**

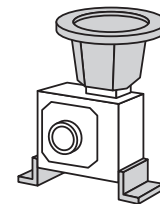

**WJQF**

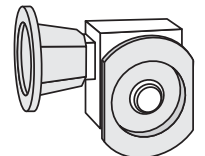

**WLQF**

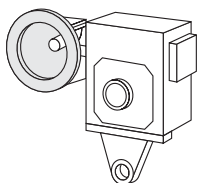

**WBWQF**

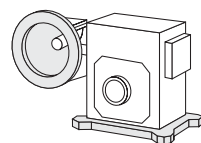

**WOWQF**

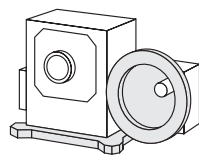

**WUWQF**

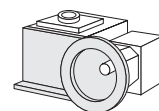

**WXWQF**

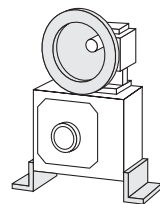

**WJWQF**

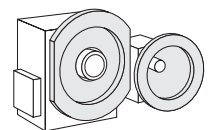

**WLWQF**

# Exact Ratios & Ratio Combinations

## Single Reduction

Nominal Total Ratio	DRIVE SIZE													
	1133	1154	1175	1206	1238	1262	1300	1325	1425	1525	1600	1700	1800	11000
5	5.0	5.0	5.0	5.0	5.0	5.17	5.0	5.17	5.17	5.13	5.0	5.13	5.13	5.13
7.5	7.5	7.5	7.5	7.5	7.5	7.5	7.5	7.5	7.5	7.5	7.5	7.4	7.4	7.33
10	10.0	10.0	10.0	10.0	10.0	10.0	10.0	10.0	10.0	10.0	10.0	9.75	9.75	9.75
15	15.0	15.0	15.0	15.0	15.0	15.0	15.0	15.0	15.0	15.0	15.0	14.67	14.67	14.67
20	20.0	20.0	20.0	20.0	20.0	20.0	20.0	20.0	20.0	20.0	20.0	20.5	20.5	20.5
25	25.0	25.0	25.0	25.0	25.0	25.0	25.0	25.0	25.0	25.0	25.0	24.5	24.5	24.5
30	30.0	30.0	30.0	30.0	30.0	30.0	30.0	30.0	30.0	30.0	30.0	29.5	29.5	29.5
40	40.0	40.0	40.0	40.0	40.0	40.0	40.0	40.0	40.0	40.0	40.0	40.0	40.0	40.0
50	50.0	50.0	50.0	50.0	50.0	50.0	50.0	50.0	50.0	50.0	50.0	50.0	50.0	50.0
60	60.0	60.0	60.0	60.0	60.0	60.0	60.0	60.0	60.0	60.0	60.0	60.0	60.0	60.0
70	...	...	...	...	...	...	...	...	...	...	...	70.0	70.0	70.0

## Double Reduction (Worm-Worm)

Nominal Total Ratio	DRIVE SIZE																	
	1133		1154		1175		1206		1238		1262		1300		1325		1425	
	Primary	Secondary	Primary	Secondary	Primary	Secondary	Primary	Secondary	Primary	Secondary	Primary	Secondary	Primary	Secondary	Primary	Secondary	Primary	Secondary
	1133	1133	1133	1154	1133	1175	1133	1206	1133	1238	1133	1262	1154	1300	1154	1325	1206	1425
75	5	15	5	15	5	15	5	15	5	15	5	15	5	15	5	15	5	15
100	5	20	5	20	5	20	5	20	5	20	5	20	5	20	5	20	5	20
150	10	15	7.5	20	10	15	10	15	10	15	7.5	20	10	15	5	30	7.5	20
200	10	20	10	20	10	20	10	20	10	20	10	20	10	20	10	20	10	20
250	10	25	10	25	10	25	10	25	10	25	10	25	10	25	10	25	10	25
300	10	30	15	20	10	30	15	20	15	20	15	20	20	15	10	30	15	20
400	20	20	20	20	20	20	20	20	20	20	20	20	20	20	20	20	20	20
500	20	25	25	20	25	20	25	20	25	20	25	20	20	25	25	20	25	20
600	20	30	30	20	20	30	30	20	20	30	30	20	20	30	20	30	30	20
750	30	25	30	25	25	30	25	30	25	30	30	25	30	25	30	25	30	25
900	30	30	30	30	30	30	30	30	30	30	30	30	30	30	30	30	30	30
1000	40	25	50	20	50	20	50	20	50	20	50	20	40	25	40	25	40	25
1200	40	30	60	20	40	30	40	30	40	30	60	20	40	30	40	30	40	30
1500	60	25	60	25	50	30	50	30	50	30	60	25	60	25	50	30	50	30
1800	60	30	60	30	60	30	60	30	60	30	60	30	60	30	60	30	60	30
2400	60	40	60	40	60	40	60	40	60	40	60	40	60	40	60	40	60	40
3000	60	50	60	50	60	50	60	50	60	50	60	50	60	50	60	50	60	50
3600	60	60	60	60	60	60	60	60	60	60	60	60	60	60	60	60	60	60

## Double Reduction (Worm-Worm) continued

Nominal Total Ratio	DRIVE SIZE									
	1525		1600		1700		1800		11000	
	Primary	Secondary	Primary	Secondary	Primary	Secondary	Primary	Secondary	Primary	Secondary
	1262	1525	1325	1600	1325	1700	1425	1800	1525	11000
75	5.17	15	5.17	15	5.17	14.67	5.17	14.67	5.13	14.67
100	5.17	20	5.17	20	5.17	20.5	5.17	20.5	5.13	20.5
150	7.5	20	10	15	7.5	20.5	7.5	20.5	10	14.67
200	10	20	10	20	10	20.5	10	20.5	10	20.5
250	10	25	10	25	10	24.5	10	24.5	10	24.5
300	15	20	20	15	15	20.5	15	20.5	20	14.67
400	20	20	20	20	20	20.5	20	20.5	20	20.5
500	25	20	25	20	25	20.5	20	24.5	25	20.5
600	30	20	30	20	30	20.5	30	20.5	30	20.5
750	30	25	30	25	30	24.5	30	24.5	15	50
900	30	30	60	15	30	29.5	30	29.5	60	14.67
1000	40	25	50	20	50	20.5	40	24.5	50	20.5
1200	40	30	60	20	60	20.5	40	29.5	60	20.5
1500	60	25	60	25	60	24.5	60	24.5	60	24.5
1800	60	30	60	30	60	29.5	60	29.5	60	29.5
2400	60	40	60	40	60	40	60	40	60	40
3000	60	50	60	50	60	50	60	50	60	50
3600	60	60	60	60	60	60	60	60	60	60

## Double Reduction (Helical-Worm)

Nominal Total Ratio	DRIVE SIZE																					
	1133		1154		1175		1206		1238		1262		1300		1325		1425		1525		1600	
	Pri- mary	Sec- ondary	Pri- mary	Sec- ondary	Pri- mary	Sec- ondary	Pri- mary	Sec- ondary	Pri- mary	Sec- ondary	Pri- mary	Sec- ondary	Pri- mary	Sec- ondary	Pri- mary	Sec- ondary	Pri- mary	Sec- ondary	Pri- mary	Sec- ondary	Pri- mary	Sec- ondary
	1	1133	1	1154	1	1175	1	1206	2	1238	2	1262	2	1300	2	1325	3	1425	3	1525	3	1600
10	2	5	2	5	2	5	2	5	2	5	2	5.17	2	5	2	5.17	2	5.17	2	5.13	2	5
15	2	7.5	2	7.5	2	7.5	2	7.5	2	7.5	2	7.5	2	7.5	2	7.5	2	7.5	2	7.5	2	7.5
20	2	10	2	10	2	10	2	10	2	10	2	10	2	10	2	10	2	10	2	10	2	10
25	5	5	5	5	5	5	5	5	5	5	5	5.17	5	5	5	5.17	5	5.17	5	5.13	5	5
30	2	15	2	15	2	15	3	10	3	10	3	10	3	10	3	10	3	10	2	15	2	15
40	4	10	4	10	4	10	4	10	4	10	4	10	4	10	4	10	4	10	2	20	2	20
45	3	15	3	15	3	15	3	15	3	15	3	15	3	15	3	15	3	15	3	15	3	15
50	5	10	5	10	5	10	5	10	5	10	5	10	5	10	5	10	5	10	2	25	2	25
60	4	15	4	15	4	15	4	15	4	15	3	20	4	15	4	15	4	15	4	15	3	20
75	5	15	5	15	5	15	5	15	5	15	5	15	5	15	5	15	5	15	5	15	3	25
80	4	20	4	20	4	20	4	20	4	20	4	20	4	20	4	20	4	20	4	20	4	20
100	4	25	5	20	5	20	5	20	5	20	5	20	5	20	5	20	5	20	5	20	4	25
125	5	25	5	25	5	25	5	25	5	25	5	25	5	25	5	25	5	25	5	25	5	25
150	5	30	5	30	5	30	5	30	5	30	5	30	5	30	5	30	5	30	5	30	5	30
200	5	40	5	40	5	40	5	40	5	40	5	40	5	40	5	40	5	40	5	40	5	40
250	5	50	5	50	5	50	5	50	5	50	5	50	5	50	5	50	5	50	5	50	5	50
300	5	60	5	60	5	60	5	60	5	60	5	60	5	60	5	60	5	60	5	60	5	60

## Double & Triple Reduction (Helical -Worm)▼

Nominal Total Ratio	DRIVE SIZE					
	1700		1800		11000	
	Primary 4115	Secondary 700	Primary 4203	Secondary 800	Primary 4207	Secondary 1000
25	5.053	5.13	4.923	5.13	5.077	5.13
37.5	5.053	7.40	4.923	7.40	5.077	7.33
50	5.053	9.75	4.923	9.75	5.077	9.75
75	5.053	14.67	4.923	14.67	5.077	14.67
100	5.053	20.5	4.923	20.5	5.077	20.5
125	5.053	24.5	4.923	24.5	5.077	24.5
138	9.357	14.67	8.908	14.67	9.492	14.67
150	5.053	29.5	4.923	29.5	5.077	29.5
185	9.357	20.5	8.908	20.5	9.492	20.5
200	5.053	40.0	4.923	40	5.077	40
210	13.95	14.67	14.03	14.67	14.47	14.67
250	24.87	9.75	26.15	9.75	24.99	9.75
280	13.95	20.5	14.03	20.5	14.47	20.5
300	5.053	60	4.923	60	5.077	60
350	13.95	24.5	14.03	24.5	14.47	24.5
375	24.87	14.67	26.15	14.67	24.99	14.67
420	13.95	29.5	14.03	29.5	14.47	29.5
500	24.87	20.5	26.15	20.5	24.99	20.5
560	13.95	40	14.03	40	14.47	40
625	24.87	24.5	26.15	24.5	24.99	24.5
700	13.95	50	14.03	50	14.47	50
750	24.87	29.5	26.15	29.5	24.99	29.5
840	13.95	60	14.03	60	14.47	60
1000	24.87	40	26.15	40	24.99	40
1250	24.87	50	26.15	50	24.99	50
1500	24.87	60	26.15	60	24.99	60
1750	24.87	70	26.15	70	24.99	70

(See Page 5 for footnotes.)

# Quick Selection Tables/Single Reduction

## 1.00 Service Factor

Ratio	Output rpm	Motor Horsepower @ 1750 rpm																				
		1/6	3	α	2	:	1	12	2	3	5	72	10	15	20	25	30	40	50	60	75	100
<b>5</b>	<b>350</b>	1133	1133	1133	1133	1133	1133	1154	1206	1238	1300	1325	1425	1425	1525	1525	1600	1700	1700	1800	11000	11000
<b>7.5</b>	<b>233</b>	1133	1133	1133	1133	1133	1154	1175	1206	1238	1300	1325	1425	1425	1525	1525	1600	1700	1700	1800	11000	11000
<b>10</b>	<b>175</b>	1133	1133	1133	1133	1133	1154	1206	1206	1238	1300	1425	1425	1525	1525	1700	1700	1700	1800	11000	11000	
<b>15</b>	<b>117</b>	1133	1133	1133	1133	1154	1175	1206	1238	1262	1325	1425	1425	1525	1600	1700	1700	1800	11000	11000		
<b>20</b>	<b>88</b>	1133	1133	1133	1154	1175	1206	1238	1262	1300	1425	1425	1525	1700	1700	1800	11000	11000				
<b>25</b>	<b>70</b>	1133	1133	1133	1154	1206	1206	1238	1262	1325	1425	1525	1600	1700	1800	11000	11000					
<b>30</b>	<b>58</b>	1133	1133	1133	1175	1206	1238	1262	1300	1325	1425	1525	1600	1800	11000	11000						
<b>40</b>	<b>44</b>	1133	1133	1154	1206	1238	1238	1300	1325	1425	1525	1600	1700	11000	11000							
<b>50</b>	<b>35</b>	1133	1154	1154	1206	1238	1262	1300	1425	1425	1525	1700	1800	11000								
<b>60</b>	<b>29</b>	1133	1154	1175	1206	1262	1300	1325	1425	1525	1600	1800	11000									
<b>70</b>	<b>25</b>	...	...	...	...	...	...	...	...	...	1700	1800	11000									

## 1.25 Service Factor

Ratio	Output rpm	Motor Horsepower @ 1750 rpm																				
		1/6	3	α	2	:	1	12	2	3	5	72	10	15	20	25	30	40	50	60	75	
<b>5</b>	<b>350</b>	1133	1133	1133	1133	1133	1154	1206	1206	1238	1300	1325	1425	1525	1525	1600	1700	1700	1700	1800	11000	11000
<b>7.5</b>	<b>233</b>	1133	1133	1133	1133	1133	1154	1154	1206	1238	1262	1300	1425	1425	1525	1600	1700	1700	1800	11000	11000	
<b>10</b>	<b>175</b>	1133	1133	1133	1133	1133	1154	1175	1206	1238	1262	1325	1425	1425	1525	1700	1700	1800	11000	11000		
<b>15</b>	<b>117</b>	1133	1133	1133	1154	1175	1206	1238	1262	1300	1425	1425	1525	1525	1700	1700	1800	11000	11000			
<b>20</b>	<b>88</b>	1133	1133	1133	1154	1206	1206	1238	1300	1325	1425	1525	1600	1700	1800	11000	11000					
<b>25</b>	<b>70</b>	1133	1133	1154	1175	1206	1238	1262	1300	1425	1425	1525	1700	1800	11000	11000						
<b>30</b>	<b>58</b>	1133	1133	1154	1206	1238	1238	1300	1325	1425	1525	1600	1700	11000	11000							
<b>40</b>	<b>44</b>	1133	1154	1175	1206	1238	1262	1300	1425	1425	1525	1700	1800	11000								
<b>50</b>	<b>35</b>	1133	1154	1206	1238	1262	1300	1325	1425	1525	1600	1800	11000									
<b>60</b>	<b>29</b>	1154	1175	1206	1238	1300	1300	1425	1425	1525	1700	1800	11000									
<b>70</b>	<b>25</b>	...	...	...	...	...	...	...	...	...	1700	1800	11000									

# Quick Selection Tables/Single Reduction

## 1.50 Service Factors

Ratio	Output rpm	Motor Horsepower @1750 rpm																		
		1/6	3	α	2	:	1	12	2	3	5	72	10	15	20	25	30	40	50	60
5	350	1133	1133	1133	1133	1154	1154	1206	1238	1262	1325	1425	1425	1525	1600	1700	1700	1800	11000	11000
7.5	233	1133	1133	1133	1133	1154	1175	1206	1238	1300	1325	1425	1425	1525	1600	1700	1800	11000	11000	
10	175	1133	1133	1333	1133	1175	1206	1238	1238	1300	1425	1425	1525	1600	1700	1800	1800	11000		
15	117	1133	1133	1133	1154	1206	1206	1238	1262	1325	1425	1525	1600	1700	1800	11000	11000			
20	88	1133	1133	1154	1175	1206	1238	1262	1300	1425	1425	1525	1700	1800	11000	11000				
25	70	1133	1133	1154	1206	1238	1238	1300	1325	1425	1525	1600	1700	1800	11000					
30	58	1133	1154	1175	1206	1238	1262	1300	1325	1425	1525	1700	1800	1800	11000					
40	44	1133	1154	1206	1238	1262	1300	1325	1425	1525	1600	1700	11000	11000						
50	35	1154	1175	1206	1238	1300	1300	1425	1425	1525	1700	1800	11000							
60	29	1154	1206	1206	1262	1300	1325	1425	1525	1600	1800	11000								
70	21.9	...	...	...	...	...	...	...	...	1700	1800	11000								

## 1.75 Service Factors

Ratio	Output rpm	Motor Horsepower @1750 rpm																		
		1/6	3	α	2	:	1	12	2	3	5	72	10	15	20	25	30	40	50	60
5	350	1133	1133	1133	1133	1154	1175	1238	1238	1300	1325	1425	1525	1525	1600	1700	1800	11000	11000	11000
7.5	233	1133	1133	1133	1133	1175	1206	1238	1238	1300	1425	1425	1525	1600	1700	1800	1800	11000	11000	
10	175	1133	1133	1333	1154	1175	1206	1238	1262	1300	1425	1425	1525	1700	1700	1800	11000			
15	117	1133	1133	1154	1175	1206	1238	1262	1300	1325	1425	1525	1600	1700	1800	11000	11000			
20	88	1133	1133	1154	1206	1238	1238	1300	1325	1425	1525	1600	1700	1800	11000					
25	70	1133	1154	1175	1206	1238	1262	1300	1325	1425	1525	1700	1700	11000	11000					
30	58	1133	1154	1175	1206	1238	1300	1325	1425	1425	1600	1700	1800	11000						
40	44	1154	1175	1206	1238	1262	1300	1425	1425	1525	1700	1800	11000							
50	35	1154	1206	1206	1262	1300	1325	1425	1425	1525	1700	11000	11000							
60	29	1154	1206	1238	1262	1300	1425	1425	1525	1600	1800	11000								
70	25	...	...	...	...	...	...	...	...	1700	11000									

# Horsepower and Torque Ratings/Single Reduction

Nominal Ratio	SPEED (rpm)		SIZE 1133			SIZE 1154			SIZE 1175			SIZE 1206			SIZE 1238		
	Input	Approx. Output	Horsepower		Output Torque (lb-in)	Horsepower		Output Torque (lb-in)	Horsepower		Output Torque (lb-in)	Horsepower		Output Torque (lb-in)	Horsepower		Output Torque (lb-in)
			Input	Output		Input	Output		Input	Output		Input	Output				
5	1750	350	1.058	0.956	172	1.615	1.464	263	1.771	1.622	292	2.510	2.323	418	3.889	3.628	653
	1170	234	0.826	0.735	198	1.317	1.174	316	1.392	1.257	339	2.104	1.922	517	3.340	3.078	829
	870	174	0.668	0.587	213	1.091	0.960	347	1.153	1.030	373	1.766	1.596	578	2.839	2.589	937
	100	20	0.101	0.081	256	0.176	0.141	443	0.186	0.152	478	0.293	0.243	766	0.486	0.408	1286
7.5	1750	233	0.906	0.809	219	1.286	1.132	306	1.667	1.516	409	2.389	2.191	592	3.605	3.323	899
	1170	156	0.662	0.581	235	1.007	0.867	350	1.306	1.169	472	1.918	1.733	700	2.872	2.609	1053
	870	116	0.528	0.457	248	0.834	0.706	383	1.058	0.936	508	1.575	1.406	763	2.396	2.151	1168
	100	13	0.077	0.061	288	0.137	0.102	484	0.160	0.130	614	0.247	0.202	954	0.393	0.322	1523
10	1750	175	0.762	0.659	237	1.021	0.869	313	1.368	1.227	442	2.092	1.896	682	3.083	2.809	1011
	1170	117	0.563	0.476	257	0.833	0.690	372	1.053	0.928	500	1.642	1.463	788	2.487	2.229	1200
	870	87	0.452	0.376	272	0.692	0.561	406	0.846	0.736	533	1.332	1.172	848	2.048	1.811	1311
	100	10	0.068	0.050	318	0.116	0.081	511	0.126	0.100	628	0.203	0.163	1026	0.325	0.261	1646
15	1750	117	0.551	0.452	244	0.774	0.619	334	1.026	0.876	473	1.561	1.366	738	2.303	2.028	1095
	1170	78	0.425	0.339	274	0.637	0.490	396	0.803	0.669	540	1.225	1.048	846	1.857	1.598	1291
	870	58	0.343	0.267	290	0.533	0.398	433	0.653	0.532	578	0.995	0.837	909	1.530	1.294	1406
	100	6.7	0.053	0.036	338	0.093	0.057	542	0.102	0.073	690	0.154	0.115	1090	0.247	0.185	1749
20	1750	88	0.437	0.344	248	0.639	0.484	349	0.814	0.677	487	1.293	1.092	782	1.901	1.619	1160
	1170	59	0.336	0.256	275	0.526	0.382	411	0.630	0.508	547	0.978	0.803	865	1.476	1.222	1316
	870	44	0.271	0.201	291	0.441	0.309	447	0.508	0.402	581	0.797	0.641	928	1.218	0.987	1430
	100	5	0.042	0.027	335	0.079	0.044	556	0.078	0.054	679	0.126	0.088	1110	0.200	0.170	1768
25	1750	70	0.375	0.279	251	0.544	0.392	353	0.665	0.537	483	1.005	0.829	746	1.510	1.249	1124
	1170	47	0.293	0.208	280	0.449	0.308	414	0.512	0.400	539	0.784	0.627	844	1.215	0.973	1310
	870	35	0.239	0.164	297	0.377	0.248	450	0.413	0.315	570	0.636	0.497	899	1.003	0.783	1418
	100	4	0.039	0.022	345	0.069	0.035	556	0.064	0.042	659	0.100	0.067	1059	0.166	0.110	1738
30	1750	58	0.341	0.241	262	0.472	0.317	343	0.597	0.451	487	0.896	0.706	763	1.319	1.049	1133
	1170	39	0.258	0.174	281	0.397	0.251	406	0.475	0.343	555	0.711	0.540	872	1.076	0.824	1330
	870	29	0.211	0.128	301	0.338	0.204	443	0.390	0.273	593	0.583	0.430	934	0.896	0.665	1445
	100	3.3	0.035	0.018	345	0.065	0.029	555	0.065	0.037	705	0.096	0.059	1115	0.155	0.095	1789
40	1750	44	0.260	0.171	247	0.391	0.241	347	0.469	0.338	486	0.710	0.524	755	1.040	0.778	1121
	1170	29	0.204	0.127	274	0.330	0.190	408	0.369	0.253	545	0.568	0.400	862	0.854	0.609	1312
	870	22	0.167	0.100	289	0.282	0.153	444	0.302	0.200	579	0.469	0.319	924	0.714	0.492	1424
	100	2.5	0.028	0.013	332	0.056	0.022	552	0.050	0.027	674	0.080	0.044	1102	0.127	0.070	1756
50	1750	35	0.211	0.131	237	0.331	0.188	339	0.377	0.258	465	0.586	0.415	748	0.847	0.602	1084
	1170	23	0.165	0.097	261	0.281	0.148	398	0.296	0.192	518	0.448	0.302	812	0.695	0.468	1261
	870	17	0.135	0.076	274	0.241	0.119	432	0.242	0.151	548	0.368	0.239	864	0.582	0.377	1364
	100	2	0.023	0.010	312	0.048	0.017	533	0.040	0.020	632	0.062	0.032	1016	0.105	0.053	1667
60	1750	29	0.181	0.104	226	0.294	0.156	339	0.330	0.212	461	0.511	0.335	728	0.674	0.466	1007
	1170	20	0.144	0.077	249	0.242	0.117	378	0.251	0.152	492	0.399	0.246	795	0.545	0.357	1152
	870	15	0.118	0.060	263	0.208	0.094	410	0.206	0.120	520	0.333	0.196	851	0.453	0.284	1235
	100	1.7	0.021	0.008	300	0.043	0.013	505	0.035	0.016	600	0.060	0.027	1015	0.080	0.039	1477



# Horsepower and Torque Ratings/Single Reduction

Nominal Ratio	SPEED (rpm)		SIZE 1262			SIZE 1300			SIZE 1325			SIZE 1425		
	Input	Approx. Output	Horsepower		Output Torque (lb-in)	Horsepower		Output Torque (lb-in)	Horsepower		Output Torque (lb-in)	Horsepower		Output Torque (lb-in)
			Input	Output		Input	Output		Input	Output		Input	Output	
5	1750	350	4.804	4.496	836	6.683	6.285	1131	9.500	8.955	1612	15.548	14.745	2742
	1170	234	4.052	3.747	1042	5.645	5.249	1413	7.694	7.172	1995	13.208	12.406	3451
	870	174	3.473	3.180	1190	4.948	4.556	1650	6.799	6.278	2349	11.627	10.827	4051
	100	20	0.608	0.513	1669	0.918	0.779	2454	1.289	1.097	3571	2.520	2.164	7043
7.5	1750	233	4.266	3.954	1068	6.291	5.849	1582	7.844	7.317	1976	14.063	13.237	3574
	1170	156	3.583	3.275	1322	5.210	4.779	1930	6.642	6.114	2469	11.740	10.923	4411
	870	116	3.010	2.720	1477	4.435	4.023	2185	5.755	5.239	2845	10.551	9.720	5279
	100	13	0.501	0.415	1962	0.765	0.636	3003	1.136	0.949	4075	2.098	1.772	8371
10	1750	175	3.903	3.575	1287	5.450	5.005	1802	7.034	6.507	2343	13.413	12.517	4508
	1170	117	3.198	2.882	1552	4.586	4.144	2232	5.974	5.446	2932	10.918	10.052	5413
	870	87	2.654	2.361	1710	3.859	3.442	2493	5.050	4.548	3293	9.573	8.715	6311
	100	10	0.430	0.348	2193	0.649	0.526	3312	0.857	0.704	4437	1.791	1.485	9358
15	1750	117	3.038	2.723	1467	4.207	3.751	2026	5.277	4.724	2551	9.673	8.769	4724
	1170	78	2.321	2.041	1648	3.507	3.062	2473	4.531	3.971	3207	7.916	7.042	5688
	870	58	1.896	1.643	1784	2.941	2.524	2742	3.858	3.324	3611	6.978	6.110	6637
	100	6.7	0.296	0.231	2187	0.498	0.378	3573	0.682	0.518	4895	1.354	1.044	9862
20	1750	88	2.371	2.051	1477	3.233	2.799	2015	4.188	3.658	2633	7.588	6.722	4840
	1170	59	1.913	1.613	1737	2.717	2.291	2467	3.547	3.020	3253	6.491	5.618	6050
	870	44	1.578	1.305	1890	2.291	1.891	2739	3.002	2.505	3628	5.686	4.828	6992
	100	5	0.258	0.186	2345	0.400	0.284	3584	0.528	0.381	4802	1.100	0.804	10136
25	1750	70	2.023	1.707	1537	2.768	2.332	2099	3.604	3.071	2765	6.242	5.413	4872
	1170	47	1.561	1.279	1722	2.319	1.895	2551	2.914	2.413	3248	5.352	4.518	6082
	870	39	1.286	1.030	1864	1.955	1.558	2821	2.460	1.990	3603	4.664	3.851	6972
	100	4	0.210	0.145	2286	0.345	0.232	3653	0.434	0.298	4701	0.899	0.628	9898
30	1750	58	1.654	1.362	1471	2.382	1.949	2105	3.003	2.454	2651	5.435	4.545	4939
	1170	39	1.325	1.055	1705	2.004	1.582	2556	2.604	2.052	3315	4.516	3.652	5899
	870	29	1.090	0.847	1840	1.694	1.301	2826	2.238	1.713	3721	4.013	3.157	6857
	100	3.3	0.179	0.118	2238	0.305	0.193	3656	0.425	0.265	5007	0.837	0.534	10092
40	1750	44	1.335	1.027	1479	1.895	1.458	2089	2.348	1.834	2641	4.204	3.366	4847
	1170	29	1.094	0.805	1735	1.557	1.144	2464	2.019	1.509	3251	3.659	2.813	6059
	870	22	0.913	0.650	1884	1.330	0.943	2731	1.729	1.250	3620	3.243	2.412	6986
	100	2.5	0.161	0.092	2328	0.252	0.141	3559	0.330	0.189	4769	0.684	0.399	10067
50	1750	35	1.076	0.792	1426	1.535	1.125	2026	1.907	1.426	2568	3.528	2.718	4894
	1170	23	0.880	0.616	1659	1.312	0.912	2456	1.634	1.163	3130	2.966	2.180	5870
	870	17	0.734	0.495	1794	1.122	0.749	2714	1.399	0.958	3467	2.620	1.855	6717
	100	2	0.130	0.070	2193	0.217	0.111	3505	0.270	0.143	4510	0.555	0.302	9497
60	1750	29	0.883	0.623	1345	1.330	0.927	2013	1.573	1.128	2437	2.696	2.001	4322
	1170	20	0.722	0.482	1556	1.100	0.722	2332	1.346	0.913	2951	2.441	1.719	5555
	870	15	0.603	0.386	1678	0.946	0.593	2576	1.153	0.750	3258	2.155	1.456	6326
	100	1.7	0.108	0.054	2036	0.188	0.088	3327	0.225	0.111	4201	0.460	0.234	8828

# Horsepower and Torque Ratings/Single Reduction

Nominal Ratio	SPEED (rpm)		SIZE 1525			SIZE 1600		
	Input	Approx. Output	Horsepower		Output Torque (lb-in)	Horsepower		Output Torque (lb-in)
			Input	Output		Input	Output	
5	1750	350	28.166	26.846	4953	35.041	33.486	6028
	1170	234	23.897	22.587	6233	29.701	28.174	7585
	870	174	21.207	19.891	7382	26.340	24.812	8984
	100	20	5.487	4.773	14009	6.701	5.845	18412
7.5	1750	233	24.006	22.687	6125	30.566	28.965	7835
	1170	156	20.409	19.088	7709	24.963	23.433	9493
	870	116	17.876	16.563	8995	21.421	19.932	10825
	100	13	4.077	3.455	16323	5.314	4.527	21388
10	1750	175	20.178	18.800	6795	23.992	22.443	8080
	1170	117	16.541	15.210	8190	20.429	18.883	10168
	870	87	14.554	13.227	9578	17.677	16.161	11703
	100	10	3.341	2.721	17142	4.372	3.590	22615
15	1750	117	14.338	12.984	7012	17.622	16.045	8664
	1170	78	12.290	10.925	8824	15.081	13.500	10904
	870	58	10.887	9.520	10341	13.155	11.597	12597
	100	6.7	2.556	1.929	18228	3.330	2.538	23987
20	1750	88	11.321	9.964	7174	13.957	12.378	8912
	1170	59	9.754	8.383	9028	12.001	10.414	11215
	870	44	8.684	7.310	10587	10.536	8.966	12985
	100	5	2.100	1.473	18561	2.734	1.944	24498
25	1750	70	9.375	8.024	7221	11.540	9.968	8971
	1170	47	8.117	6.751	9088	9.968	8.387	11290
	870	35	7.259	5.888	10660	8.791	7.225	13080
	100	4	1.808	1.184	18641	2.348	1.562	24605
30	1750	58	8.043	6.699	7235	10.235	8.610	9356
	1170	39	6.997	5.636	9104	8.538	6.966	11252
	870	29	6.282	4.917	10681	7.556	5.999	13032
	100	3.3	1.608	0.987	18653	2.083	1.299	24551
40	1750	44	6.292	4.971	7159	7.712	6.176	8894
	1170	29	5.520	4.183	9009	6.744	5.197	11193
	870	22	4.993	3.649	10571	6.015	4.480	12977
	100	2.5	1.342	0.732	18434	1.735	0.966	24333
50	1750	35	5.344	4.016	7231	6.282	4.797	8635
	1170	23	4.543	3.248	8746	5.533	4.036	10866
	870	17	4.135	2.834	10263	4.966	3.480	12601
	100	2	1.159	0.568	17886	1.494	0.750	23609
60	1750	29	4.265	3.055	6598	5.388	3.927	8534
	1170	20	3.797	2.570	8304	4.594	3.177	10263
	870	15	3.475	2.243	9744	4.143	2.738	11894
	100	1.7	1.009	0.449	16976	1.298	0.591	22346

# Horsepower and Torque Ratings/Single Reduction

Nominal Ratio	SPEED (rpm)		SIZE 1700			SIZE 1800			SIZE 11000		
	Input	Approx. Output	Horsepower		Output Torque (lb-in)	Horsepower		Output Torque (lb-in)	Horsepower		Output Torque (lb-in)
			Input	Output		Input	Output		Input	Output	
5	1750	350	51.170	49.115	9062	66.875	64.312	11866	108.837	104.952	18899
	1170	234	43.353	41.324	11404	56.618	54.111	14932	88.498	84.908	23431
	870	174	38.427	36.392	13506	50.159	47.652	17685	78.334	74.774	27750
	100	20	9.250	8.181	26416	13.930	12.417	36447	22.115	19.802	63935
7.5	1750	233	41.546	39.684	10572	54.370	52.053	13867	87.787	84.353	22817
	1170	156	35.247	33.389	13304	46.092	43.796	17451	71.469	68.243	26947
	870	116	30.763	28.923	15499	40.874	38.569	20668	63.321	60.098	31914
	100	13	6.968	6.089	28388	9.723	8.536	39793	16.549	14.659	67727
10	1750	175	35.744	33.884	11893	45.052	42.807	15417	67.117	64.006	22466
	1170	117	30.368	28.509	14967	36.771	34.631	18181	56.888	53.853	28273
	870	87	26.470	24.631	17391	32.648	30.498	21532	50.458	47.425	33484
	100	10	6.153	5.256	32282	7.960	6.831	41958	13.678	11.837	72712
15	1750	117	27.017	25.266	13609	35.175	33.023	17789	52.789	49.825	26308
	1170	78	22.136	20.441	16143	28.791	26.716	21099	44.862	41.921	33107
	870	58	19.580	17.881	18991	25.297	23.230	24672	39.876	36.918	39209
	100	6.7	4.157	3.436	31744	5.747	4.820	44195	9.949	8.365	77295
20	1750	88	19.916	18.199	13431	26.966	24.767	17738	40.433	37.394	27597
	1170	59	17.045	15.312	16903	22.162	20.037	22118	34.481	31.462	34730
	870	44	15.130	13.392	19880	19.506	17.390	25815	30.748	27.707	41131
	100	5	3.345	2.595	33520	4.630	3.623	46792	8.011	6.350	82011
25	1750	70	17.587	15.874	14292	22.814	20.727	18661	35.567	32.566	29321
	1170	47	14.060	12.444	16417	18.791	16.769	22122	29.224	26.346	34756
	870	35	12.906	11.234	19931	16.649	14.624	25946	26.104	23.201	41163
	100	4	2.821	2.124	32790	3.862	2.943	45421	6.703	5.175	79871
30	1750	58	14.112	12.576	13356	17.925	16.164	17166	28.529	25.831	27433
	1170	39	11.909	10.382	16491	14.993	13.257	21058	24.435	21.734	34523
	870	29	10.791	9.234	19725	13.674	11.890	25398	21.272	18.617	39769
	100	3.3	2.295	1.681	31233	2.936	2.211	41088	5.490	4.122	76598
40	1750	44	11.315	9.677	13861	14.079	12.158	17507	22.691	19.840	28419
	1170	29	9.178	7.622	16416	12.170	10.229	22032	18.795	16.051	34571
	870	22	8.450	6.845	19828	10.881	8.933	25875	16.908	14.135	40943
	100	2.5	1.935	1.278	32194	2.644	1.773	44687	4.539	3.105	78246
50	1750	35	9.090	7.517	13537	11.317	9.460	17028	18.175	15.428	27782
	1170	23	7.426	5.930	15966	9.838	7.959	21429	15.128	12.482	33605
	870	17	6.857	5.317	19250	8.837	6.951	25166	13.204	10.618	38444
	100	2	1.615	0.988	31109	2.224	1.380	43469	3.793	2.411	75935
60	1750	29	7.003	5.657	12220	9.410	7.695	16723	13.983	11.624	25107
	1170	20	6.033	4.687	15143	7.629	6.014	19430	12.152	9.780	31597
	870	15	5.513	4.146	18014	7.126	5.446	23663	10.762	8.416	36566
	100	1.7	1.273	0.744	28131	1.748	1.038	39244	3.013	1.829	69119
70	1750	25	5.740	4.484	11300	7.665	6.084	15338	11.431	9.220	23235
	1170	16.7	4.963	3.709	13979	6.242	4.755	17921	9.979	7.758	29240
	870	12.4	4.567	3.290	16676	5.854	4.306	21829	8.845	6.655	33736
	100	1.4	1.094	0.595	26222	1.476	0.821	36215	2.589	1.464	64584

# Single Reduction/Basic Drive

Type  
**WBM**

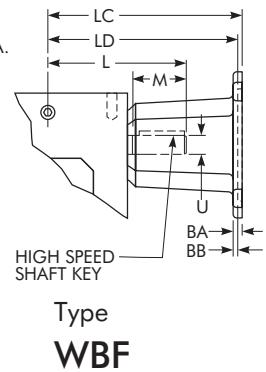
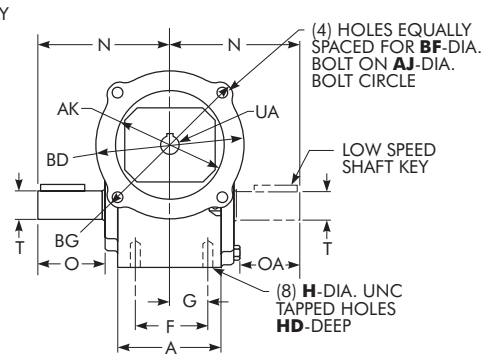
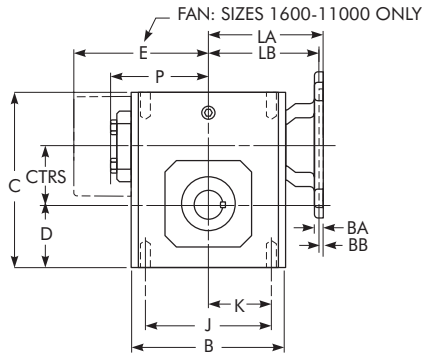

Type  
**WB**

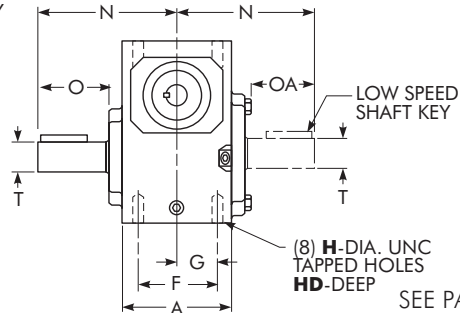
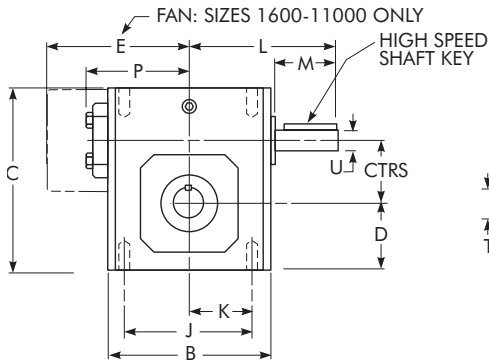

SEE PAGE 31 FOR MOTOR MOUNTING DIMENSIONS.

(Continued on next page)

DRIVE SIZE ★	CTRS	A	B	C	D	E	F	G	H	HD	J	K	L	M •	N	O +	OA +	P	Low Speed Shaft	
																			T	Key
																			-.0005 -.0015	
1133	1.33	2.82	3.80	4.66	1.72	...	2.00	1.00	.3125-18	.50	3.25	1.63	3.82	1.76	4.00	2.16	1.94	2.61	.6250	.188 x .188 x 1.50
1154	1.54	3.44	4.88	5.38	1.91	...	2.75	1.38	.3125-18	.63	4.19	2.09	4.35	1.76	4.31	2.11	1.90	3.14	.7500	.188 x .188 x 1.50
1175	1.75	3.56	5.06	5.75	2.06	...	2.75	1.38	.3125-18	.63	4.19	2.09	4.45	1.76	4.31	2.05	1.84	3.24	.8750	.188 x .188 x 1.38
1206	2.06	3.81	5.80	6.38	2.28	...	3.00	1.50	.3125-18	.63	4.75	2.38	4.82	1.76	4.68	2.29	2.08	3.61	1.0000	.250 x .250 x 1.44
1238	2.38	4.06	6.12	6.94	2.50	...	2.88	1.44	.3750-16	.56	5.00	2.50	5.51	2.38	5.14	2.66	2.44	3.77	1.1250	.250 x .250 x 1.75
1262	2.63	4.84	7.12	8.00	2.94	...	3.38	1.69	.3750-16	.69	6.38	3.19	6.07	2.38	5.63	2.73	2.52	4.34	1.1250	.250 x .250 x 1.44
1300	3.00	5.25	8.12	8.88	3.25	...	4.00	2.00	.4375-14	.88	7.00	3.50	6.57	2.38	6.75	3.60	3.36	4.84	1.2500	.250 x .250 x 2.25
1325	3.25	5.75	8.50	9.38	3.50	...	4.00	2.00	.4375-14	.88	7.50	3.75	6.76	2.38	7.06	3.66	3.42	5.02	1.3750	.313 x .313 x 2.50
1425	4.25	6.13	10.25	11.38	4.44	...	5.00	2.50	.6250-11	1.00	8.50	4.25	9.57	3.47	8.12	4.50	4.21	6.10	1.8750	.500 x .500 x 3.06
1525	5.25	7.19	13.00	14.00	5.12	...	5.81	2.91	.6250-11	1.25	11.00	5.50	10.88	3.38	9.06	4.78	4.53	7.50	2.0000	.500 x .500 x 3.50
1600	6.00	8.13	14.25	16.50	6.50	11.13	6.38	3.19	.6250-11	1.00	12.75	6.38	11.78	3.41	10.00	4.65	4.65	...	2.2500	.500 x .500 x 4.00
1700	7.00	7.63	14.88	18.91	7.59	11.37	5.50	2.75	1.0000-8	1.56	12.50	6.25	11.50	2.97	11.76	5.65	5.65	...	2.7500	.625 x .625 x 4.00
1800	8.00	8.63	17.00	20.96	8.86	12.52	6.50	3.25	1.0000-8	1.66	14.25	7.13	12.50	2.84	12.25	5.98	5.98	...	3.0000	.750 x .750 x 4.50
11000	10.00	9.53	20.88	25.47	10.36	14.69	6.88	3.44	1.2500-7	2.04	17.75	8.88	15.50	3.76	14.75	6.76	6.76	...	3.7500	.875 x .875 x 5.00

(See Page 5 for footnotes.)

Type  
**WBQM**

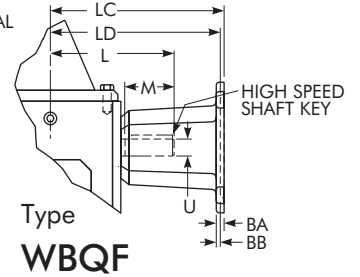
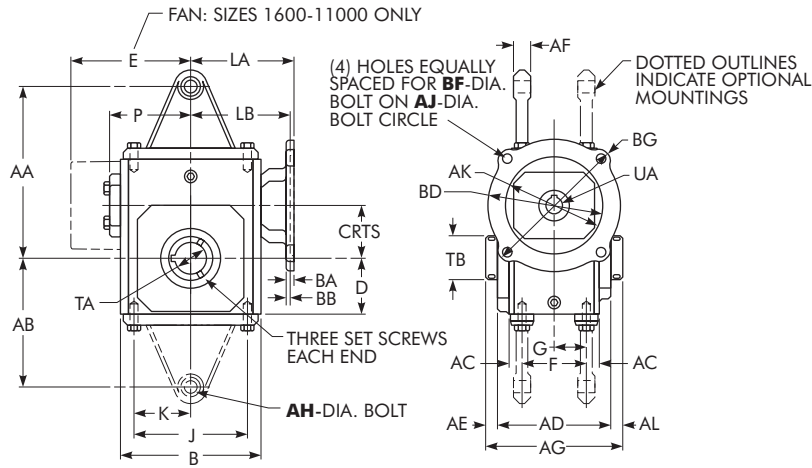

Type  
**WBQ**

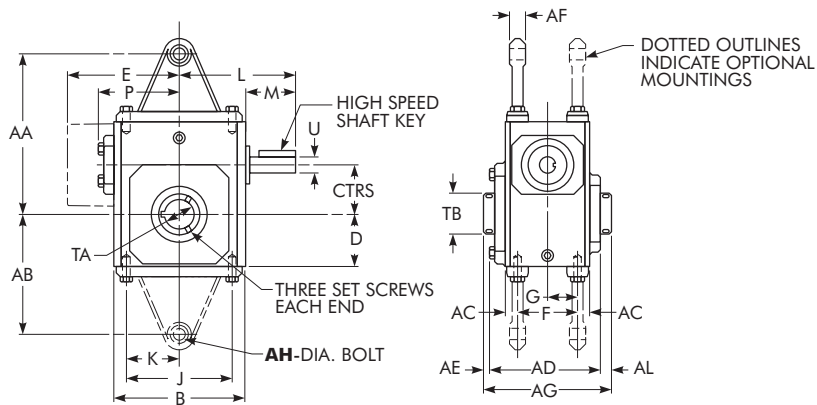

SEE PAGE 31 FOR MOTOR MOUNTING DIMENSIONS.

(Continued from preceding page)

DRIVE SIZE ★	Hollow Low Speed Shaft			High Speed Shaft		AA	AB	AC	AD	AE	AF	AG	AH	AL	Approx. Wt - lb						
	TA Max □ +.002 -.000	TB	Key	U -.0005 -.0015	Key										WBM	WBF	WB	WBQM	WBQF	WBQ	
1133	.625	1.00	.188 x .188 x 1.25	.5000	.125 x .125 x 1.44	4.19	2.97	.41	3.90	.53	.25	4.75	.53	.32	17	21	14	17	21	14	
1154	.625	1.00	.188 x .188 x 1.25	.6250	.188 x .188 x 1.50	5.97	4.41	.35	4.61	.51	.75	5.42	.53	.30	22	27	20	22	27	20	
1175	1.000	1.44	.250 x .250 x 2.50	.6250	.188 x .188 x 1.50	6.19	4.56	.41	4.73	.49	.75	5.50	.53	.28	24	29	22	25	30	23	
1206	1.438	1.94	.375 x .375 x 3.00	.6250	.188 x .188 x 1.50	7.24	5.43	.41	4.99	.61	.75	6.00	.53	.40	30	34	27	33	37	28	
1238	1.438	1.94	.375 x .375 x 3.00	.7500	.188 x .188 x 1.75	7.69	5.75	.59	5.18	.51	.75	6.00	.53	.31	46	47	38	47	52	44	
1262	1.438	1.94	.375 x .375 x 3.00	.7500	.188 x .188 x 1.75	8.81	6.69	.73	6.01	.60	.75	7.00	.53	.39	59	60	51	57	62	54	
1300	1.938	2.51	.500 x .500 x 3.00	.8750	.188 x .188 x 1.75	10.63	8.25	.63	6.53	.60	.75	7.50	.53	.36	80	91	76	80	91	76	
1325	1.938	2.51	.500 x .500 x 3.00	.8750	.188 x .188 x 1.75	10.88	8.50	.88	7.04	.54	.75	7.88	.53	.29	83	94	79	83	94	79	
1425	2.188	2.75	.500 x .500 x 3.00	1.2500	.250 x .250 x 2.88	11.94	9.44	.56	7.53	.63	.75	8.50	.53	.34	146	154	136	146	154	136	
1525	3.438	4.26	.875 x .875 x 4.00	1.2500	.250 x .250 x 3.00	13.88	10.12	.69	8.85	.97	1.00	10.50	.66	.68	247	254	232	247	254	222	
1600	3.438	4.18	.875 x .875 x 4.00	1.5000	.375 x .375 x 3.00	15.00	11.50	.88	10.52	.52	.38	11.50	.66	.52	344	361	321	344	361	321	
1700	3.938	4.92	1.000 x 1.000 x 7.00	1.6250	.375 x .375 x 2.87	...	...	1.06	11.36	1.09	...	13.50	...	1.09	...	429	399	...	429	399	
1800	4.438	5.55	1.000 x 1.000 x 8.50	1.8750	.500 x .500 x 2.81	...	...	1.06	12.48	1.03	...	14.50	...	1.03	...	612	582	...	612	582	
11000	5.438	6.67	1.250 x 1.250 x 12.00	2.2500	.500 x .500 x 3.69	...	...	1.33	15.78	1.39	...	18.50	...	1.39	...	...	...	904	...	...	904

# Assemblies \*

Reverse all arrows for opposite rotation of high speed shaft.

**WBM  
&  
WBF**

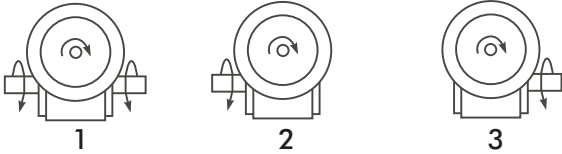

**WB**

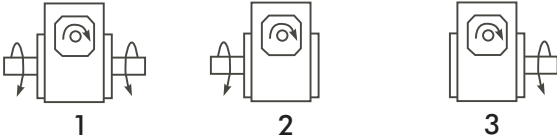

**WBQM  
&  
WBQF**

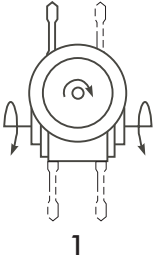

**WBQ**

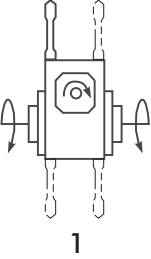

(See Page 5 for footnotes.)

# Motor Data

## NEMA Motor Flange Face Locations — Inches

DRIVE SIZE	56C/140TC		180TC		210TC		250TC	
	LA	LC	LB	LD	LB	LD	LB	LD
1133	3.46	6.07	...	...	...	...	...	...
1154	3.99	6.60	...	...	...	...	...	...
1175	4.09	6.70	...	...	...	...	...	...
1206	4.46	7.07	...	...	...	...	...	...
1238	4.63	7.76	5.06	8.76	...	8.76	...	...
1262	5.19	8.32	5.62	9.32	...	9.32	...	...
1300	5.69	8.82	6.12	9.82	6.56	9.82	...	...
1325	5.88	9.01	6.31	10.01	6.75	10.01	...	...
1425	6.45	11.81	7.21	12.90	7.21	12.90	7.77	13.46
1525	7.85	13.21	8.61	14.30	8.61	14.30	9.17	14.86
1600	10.45	...	9.33	15.88	9.33	15.88	9.94	16.50
1700	...	...	...	15.50	...	15.50	...	15.50
1800	...	...	...	...	...	16.58	...	16.58

## NEMA Motor Mounting Dimensions — Inches

FRAME SIZE	AJ	AK	BA	BB	BD	BF	BG	UA	Keyway
56C	5.88	4.50	.38	...	5.88	.41	6.64	.625	.1875 x .0938
140TC	5.88	4.50	.38	...	5.88	.41	6.64	.875	.1875 x .0938
180TC	7.25	8.50	...	.50	9.00	.53	...	1.125	.2500 x .1250
210TC	7.25	8.50	...	.50	9.00	.53	...	1.375	.3125 x .1562
250TC	7.25	8.50	...	.50	9.00	.53	...	1.625	.3750 x .1875

## IEC B5 & B3/B5 Motor Flange Dimensions \* — Inches

DRIVE SIZE	D63D	D71D	D80D	D90D	D100LD/D112MD	D132D
	LA	LA	LA	LA	LA	LA
1133	2.62	2.65	2.89	...	...	...
1154	3.15	3.18	3.42	...	...	...
1175	3.25	3.28	3.52	...	...	...
1206	3.62	3.65	3.89	...	...	...
1238	...	3.72	4.34	...	...	...
1262	...	4.28	4.90	4.90	5.30	...
1300	...	4.78	5.41	5.41	5.80	...
1325	...	4.97	5.59	5.59	5.99	...
1425	...	...	...	6.38	6.39	7.17
1525	...	...	...	7.78	7.78	8.57

## IEC B5 & B3/B5 Metric Motor Mounting Dimensions — Millimeters

FRAME SIZE	AJ	AK	BA	BD	BF	BG	UA	Keyway
D63D	115	95	10	117	M8 x 1.25	131	11	4 x 2.0
D71D	130	110	11	132	M8 x 1.25	146	14	5 x 2.5
D80D	165	130	15	165	M10 x 1.50	184	19	6 x 3.0
D90D	165	130	15	165	M10 x 1.50	184	24	8 x 3.5
D100LD/D112MD	215	180	18	216	M12 x 1.75	237	28	8 x 3.5
D132D	265	230	18	267	M12 x 1.75	290	38	10 x 4.0

(See Page 5 for footnotes.)

# Single Reduction/Worm Over

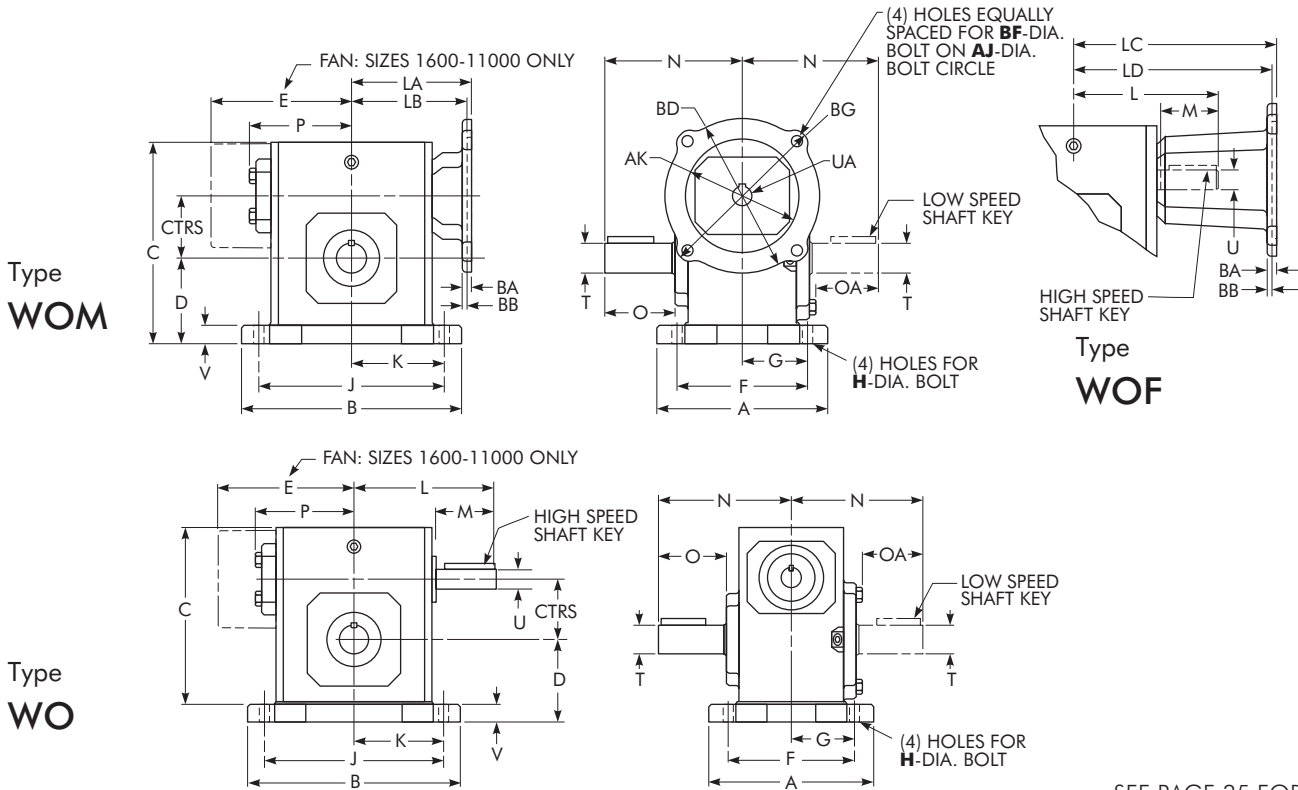

SEE PAGE 35 FOR MOTOR MOUNTING DIMENSIONS.

(Continued on next page)

DRIVE SIZE ★	CTRS	A	B	C	D	E	F	G	H	J	K	L	M •	N	O ♦	OA ♦	P	Low Speed Shaft	
																		T	Key
																		-.0005 -.0015	
1133	1.33	5.38	5.37	5.19	2.25	...	4.38 ▲	2.19 ▲	.34	4.37	2.19	3.82	1.76	4.00	2.16	1.94	2.61	.6250	.188 x .188 x 1.50
1154	1.54	5.56	6.50	5.97	2.50	...	4.31	2.16	.41	5.25	2.63	4.35	1.76	4.31	2.11	1.90	3.14	.7500	.188 x .188 x 1.50
1175	1.75	5.75	6.99	6.44	2.75	...	4.50	2.25	.41	5.75	2.88	4.45	1.76	4.31	2.05	1.84	3.24	.8750	.188 x .188 x 1.38
1206	2.06	6.00	7.69	7.09	3.00	...	4.69	2.34	.47	6.38	3.19	4.82	1.76	4.68	2.29	2.08	3.61	1.0000	.250 x .250 x 1.44
1238	2.38	6.19	8.37	7.69	3.25	...	4.88	2.44	.47	7.06	3.53	5.51	2.38	5.14	2.66	2.44	3.77	1.1250	.250 x .250 x 1.75
1262	2.63	6.50	9.25	8.75	3.69	...	5.25	2.63	.53	8.00	4.00	6.07	2.38	5.63	2.73	2.52	4.34	1.1250	.250 x .250 x 1.44
1300	3.00	7.50	10.00	9.63	4.00	...	5.88	2.94	.53	8.44	4.22	6.57	2.38	6.75	3.60	3.36	4.84	1.2500	.250 x .250 x 2.25
1325	3.25	7.75	11.12	10.25	4.38	...	6.13	3.06	.53	9.50	4.75	6.76	2.38	7.06	3.66	3.42	5.02	1.3750	.313 x .313 x 2.50
1425	4.25	9.75	13.24	12.38	5.44	...	7.63	3.81	.66	11.12	5.56	9.57	3.47	8.12	4.50	4.21	6.10	1.8750	.500 x .500 x 3.06
1525	5.25	10.50	16.24	15.13	6.25	...	8.38	4.19	.78	14.12	7.06	10.88	3.38	9.06	4.78	4.53	7.50	2.0000	.500 x .500 x 3.50
1600	6.00	12.00	18.99	17.75	7.75	11.13	9.50	4.75	.91	16.49	8.25	11.78	3.41	10.00	4.65	4.65	...	2.2500	.500 x .500 x 4.00
1700	7.00	13.38	15.38	20.33	9.00	11.37	11.25	5.63	1.13	13.00	6.50	11.50	2.97	11.76	5.65	5.65	...	2.7500	.625 x .625 x 4.00
1800	8.00	13.50	17.37	22.61	10.50	12.52	11.50	5.75	1.13	14.75	7.38	12.50	2.84	12.25	5.98	5.98	...	3.0000	.750 x .750 x 4.50
11000	10.00	16.88	21.24	27.12	12.00	14.69	14.00	7.00	1.44	17.00	8.50	15.50	3.76	14.75	6.80	6.80	...	3.7500	.875 x .875 x 5.00

(See Page 5 for footnotes.)



Type  
**WOQM**

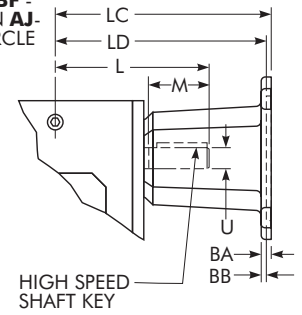
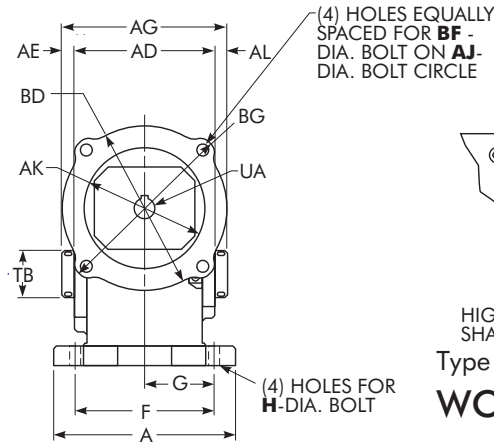
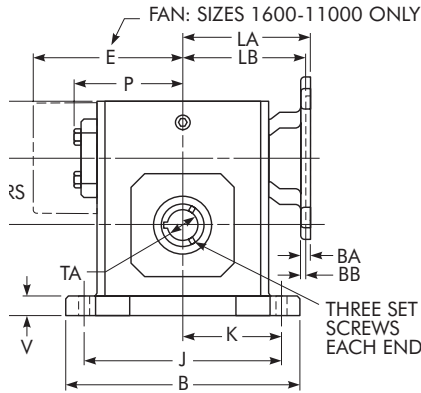

Type  
**WOQF**

Type  
**WOQ**

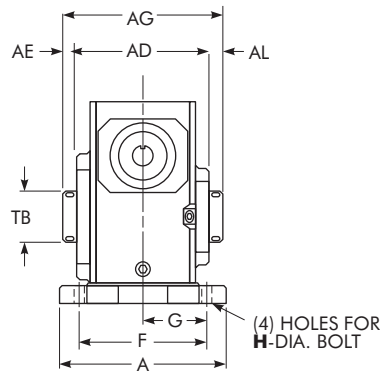
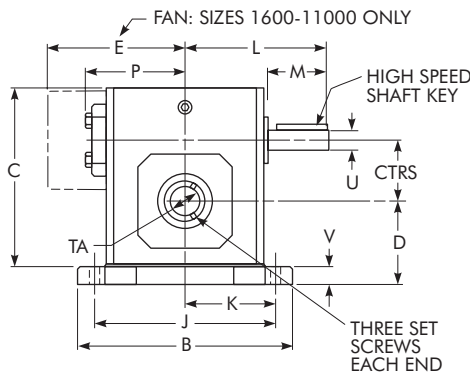

SEE PAGE 35 FOR MOTOR MOUNTING DIMENSIONS.

(Continued from preceding page)

DRIVE SIZE ★	Hollow Low Speed Shaft			High Speed Shaft		V	AD	AE	AG	AL	Approx. Wt - lb					
	TA Max ■ +.002 -.000	TB	Key	U -.0005 -.0015	Key						WOM	WOF	WO	WOQM	WOQF	WOQ
<b>1133</b>	.625	1.00	.188 x .188 x 1.25	.5000	.125 x .125 x 1.44	.53	3.90	.53	4.75	.32	19	24	17	19	24	17
<b>1154</b>	.625	1.00	.188 x .188 x 1.25	.6250	.188 x .188 x 1.50	.59	4.61	.51	5.42	.30	24	29	22	24	29	22
<b>1175</b>	1.000	1.44	.250 x .250 x 2.50	.6250	.188 x .188 x 1.50	.69	4.73	.49	5.50	.28	26	32	25	27	33	26
<b>1206</b>	1.438	1.94	.375 x .375 x 3.00	.6250	.188 x .188 x 1.50	.72	4.99	.61	6.00	.40	33	37	30	36	40	33
<b>1238</b>	1.438	1.94	.375 x .375 x 3.00	.7500	.188 x .188 x 1.75	.75	5.18	.51	6.00	.31	54	60	46	55	61	47
<b>1262</b>	1.438	1.94	.375 x .375 x 3.00	.7500	.188 x .188 x 1.75	.75	6.01	.60	7.00	.39	69	70	61	67	68	59
<b>1300</b>	1.938	2.51	.500 x .500 x 3.00	.8750	.188 x .188 x 1.75	.75	6.53	.60	7.50	.36	96	107	92	96	107	92
<b>1325</b>	1.938	2.51	.500 x .500 x 3.00	.8750	.188 x .188 x 1.75	.88	7.04	.54	7.88	.29	99	110	95	99	110	95
<b>1425</b>	2.188	2.75	.500 x .500 x 3.00	1.2500	.250 x .250 x 2.88	1.00	7.53	.63	8.50	.34	156	164	146	156	164	146
<b>1525</b>	3.438	4.26	.875 x .875 x 4.00	1.2500	.250 x .250 x 3.00	1.13	8.85	.97	10.50	.68	269	276	254	269	276	254
<b>1600</b>	3.438	4.18	.875 x .875 x 4.00	1.5000	.375 x .375 x 3.00	1.25	10.52	.52	11.50	.52	364	371	341	364	371	341
<b>1700</b>	3.938	4.92	1.000 x 1.000 x 7.00	1.6250	.375 x .375 x 2.87	1.42	11.36	1.09	13.50	1.09	...	470	440	...	470	440
<b>1800</b>	4.438	5.55	1.000 x 1.000 x 7.00	1.8750	.500 x .500 x 2.81	1.65	12.48	1.03	14.50	1.03	...	660	630	...	660	630
<b>11000</b>	5.438	6.67	1.250 x 1.250 x 12.00	2.2500	.500 x .500 x 3.69	1.65	15.78	1.39	18.50	1.39	...	...	980	...	...	980

# Assemblies \*

Reverse all arrows for opposite rotation of high speed shaft.

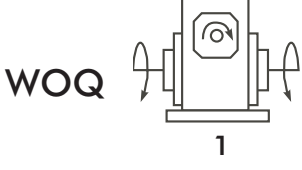
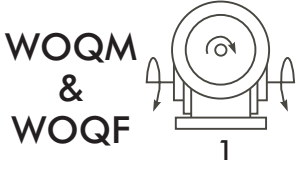
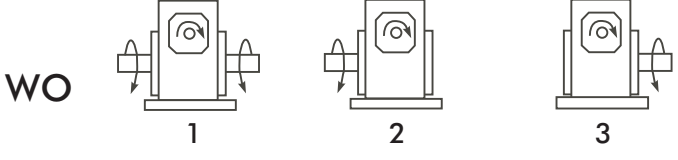
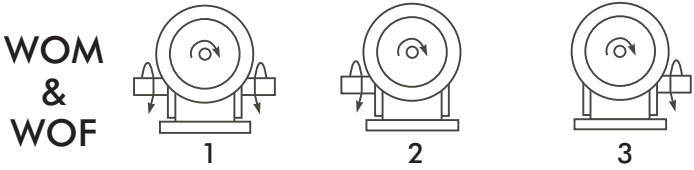

(See Page 5 for footnotes.)

# Motor Data

## NEMA Motor Flange Face Locations — Inches

DRIVE SIZE	56C/140TC		180TC		210TC		250TC	
	LA	LC	LB	LD	LB	LD	LB	LD
1133	3.46	6.07	...	...	...	...	...	...
1154	3.99	6.60	...	...	...	...	...	...
1175	4.09	6.70	...	...	...	...	...	...
1206	4.46	7.07	...	...	...	...	...	...
1238	4.63	7.76	5.06	8.76	...	8.76	...	...
1262	5.19	8.32	5.62	9.32	...	9.32	...	...
1300	5.69	8.82	6.12	9.82	6.56	9.82	...	...
1325	5.88	9.01	6.31	10.01	6.75	10.01	...	...
1425	6.45	11.81	7.21	12.90	7.21	12.90	7.77	13.46
1525	7.85	13.21	8.61	14.30	8.61	14.30	9.17	14.86
1600	10.45	...	9.33	15.88	9.33	15.88	9.94	16.50
1700	...	...	...	15.50	...	15.50	...	15.50
1800	...	...	...	...	...	16.58	...	16.58

## NEMA Motor Mounting Dimensions — Inches

FRAME SIZE	AJ	AK	BA	BB	BD	BF	BG	UA	Keyway
56C	5.88	4.50	.38	...	5.88	.41	6.64	.625	.1875 x .0938
140TC	5.88	4.50	.38	...	5.88	.41	6.64	.875	.1875 x .0938
180TC	7.25	8.50	...	.50	9.00	.53	...	1.125	.2500 x .1250
210TC	7.25	8.50	...	.50	9.00	.53	...	1.375	.3125 x .1562
250TC	7.25	8.50	...	.50	9.00	.53	...	1.625	.3750 x .1875

## IEC B5 & B3/B5 Motor Flange Dimensions \* — Inches

DRIVE SIZE	D63D	D71D	D80D	D90D	D100LD/D112MD	D132D
	LA	LA	LA	LA	LA	LA
1133	2.62	2.65	2.89	...	...	...
1154	3.15	3.18	3.42	...	...	...
1175	3.25	3.28	3.52	...	...	...
1206	3.62	3.65	3.89	...	...	...
1238	...	3.72	4.34	...	...	...
1262	...	4.28	4.90	4.90	5.30	...
1300	...	4.78	5.41	5.41	5.80	...
1325	...	4.97	5.59	5.59	5.99	...
1425	...	...	...	6.38	6.39	7.17
1525	...	...	...	7.78	7.78	8.57

## IEC B5 & B3/B5 Metric Motor Mounting Dimensions — Millimeters

FRAME SIZE	AJ	AK	BA	BD	BF	BG	UA	Keyway
D63D	115	95	10	117	M8 x 1.25	131	11	4 x 2.0
D71D	130	110	11	132	M8 x 1.25	146	14	5 x 2.5
D80D	165	130	15	165	M10 x 1.50	184	19	6 x 3.0
D90D	165	130	15	165	M10 x 1.50	184	24	8 x 3.5
D100LD/D112MD	215	180	18	216	M12 x 1.75	237	28	8 x 3.5
D132D	265	230	18	267	M12 x 1.75	290	38	10 x 4.0

(See Page 5 for footnotes.)

# Single Reduction/Worm Under

Type  
**WUM**

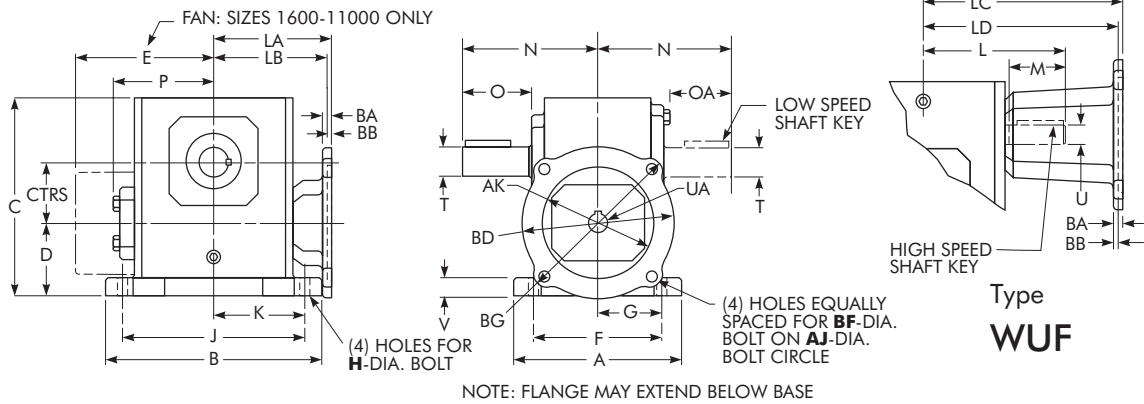

Type  
**WU**

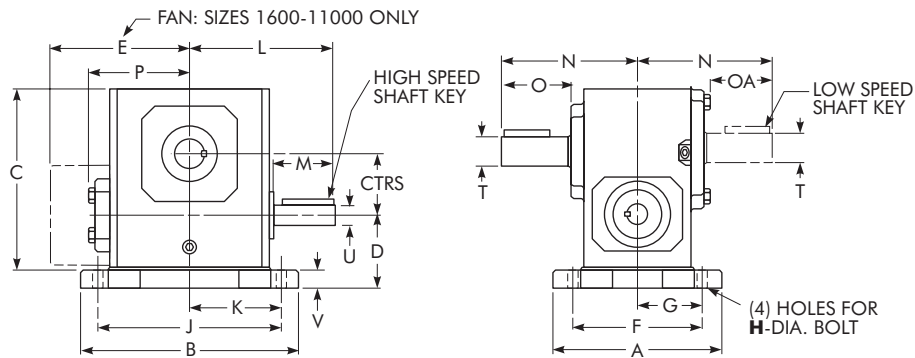

SEE PAGE 39 FOR MOTOR MOUNTING DIMENSIONS.

(Continued on next page)

DRIVE SIZE ★	CTRS	A	B	C	D	E	F	G	H	J	K	L	M •	N	O ♦	OA ♦	P	Low Speed Shaft	
																		T	Key
																		-.0005 -.0015	
<b>1133</b>	1.33	5.38	5.37	5.19	2.14	...	4.38 ▲	2.19 ▲	.34	4.37	2.19	3.82	1.76	4.00	2.16	1.94	2.61	.6250	.188 x .188 x 1.50
<b>1154</b>	1.54	5.56	6.50	5.97	2.52	...	4.31	2.16	.41	5.25	2.63	4.35	1.76	4.31	2.11	1.90	3.14	.7500	.188 x .188 x 1.50
<b>1175</b>	1.75	5.75	6.99	6.44	2.63	...	4.50	2.25	.41	5.75	2.88	4.45	1.76	4.31	2.05	1.84	3.24	.8750	.188 x .188 x 1.38
<b>1206</b>	2.06	6.00	7.69	7.09	2.75	...	4.69	2.34	.47	6.38	3.19	4.82	1.76	4.68	2.29	2.08	3.61	1.0000	.250 x .250 x 1.44
<b>1238</b>	2.38	6.19	8.37	7.69	2.81	...	4.88	2.44	.47	7.06	3.53	5.51	2.38	5.14	2.66	2.44	3.77	1.1250	.250 x .250 x 1.75
<b>1262</b>	2.63	6.50	9.25	8.75	3.19	...	5.25	2.63	.53	8.00	4.00	6.07	2.38	5.63	2.73	2.52	4.34	1.1250	.250 x .250 x 1.44
<b>1300</b>	3.00	7.50	10.00	9.63	3.38	...	5.88	2.94	.53	8.44	4.22	6.57	2.38	6.75	3.60	3.36	4.84	1.2500	.250 x .250 x 2.25
<b>1325</b>	3.25	7.75	11.12	10.25	3.50	...	6.13	3.06	.53	9.50	4.75	6.76	2.38	7.06	3.66	3.42	5.02	1.3750	.313 x .313 x 2.50
<b>1425</b>	4.25	9.75	13.24	12.38	3.69	...	7.63	3.81	.66	11.12	5.56	9.57	3.47	8.12	4.50	4.21	6.10	1.8750	.500 x .500 x 3.06
<b>1525</b>	5.25	10.50	16.24	15.13	4.76	...	8.38	4.19	.78	14.12	7.06	10.88	3.38	9.06	4.78	4.53	7.50	2.0000	.500 x .500 x 3.50
<b>1600</b>	6.00	12.00	18.99	17.75	5.25	11.13	9.50	4.75	.91	16.49	8.25	11.78	3.41	10.00	4.65	4.65	...	2.2500	.500 x .500 x 4.00
<b>1700</b>	7.00	13.38	15.38	20.33	5.74	11.37	11.25	5.63	1.13	13.00	6.50	11.50	2.97	11.76	5.65	5.65	...	2.7500	.625 x .625 x 4.00
<b>1800</b>	8.00	13.50	17.37	22.61	5.75	12.52	11.50	5.75	1.13	14.75	7.38	12.50	2.84	12.25	5.98	5.98	...	3.0000	.750 x .750 x 4.50
<b>11000</b>	10.00	16.88	21.24	27.12	6.76	14.69	14.00	7.00	1.44	17.00	8.50	15.50	3.76	14.75	6.80	6.80	...	3.7500	.875 x .875 x 5.00

(See Page 5 for footnotes.)

Type  
**WUQM**

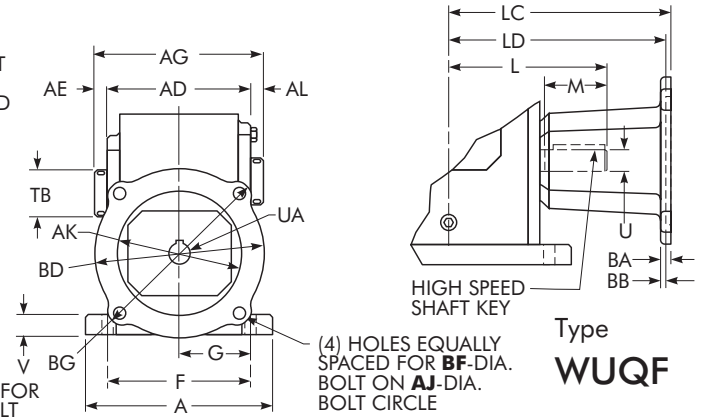
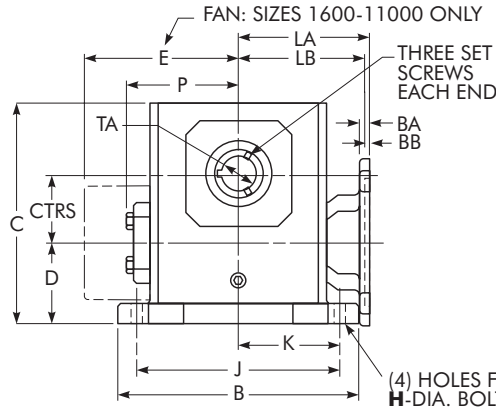

NOTE: FLANGE MAY EXTEND BELOW BASE

Type  
**WUQ**

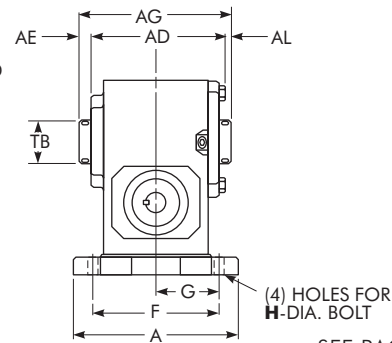
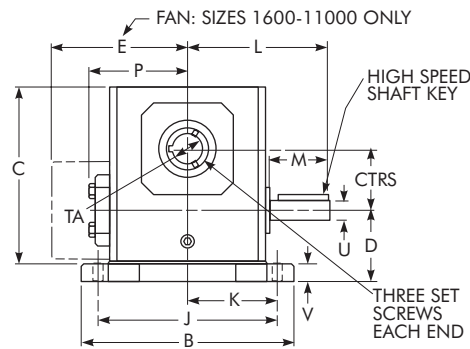

SEE PAGE 39 FOR MOTOR MOUNTING DIMENSIONS.

(Continued from preceding page)

DRIVE SIZE ★	Hollow Low Speed Shaft			High Speed Shaft			Approx. Wt - lb									
	TA Max ■ +.002 -.000	TB	Key	U -.0005 -.0015	Key	V	AD	AE	AG	AL	WUM	WUF	WU	WUQM	WUQF	WUQ
<b>1133</b>	.625	1.00	.188 x .188 x 1.25	.5000	.125 x .125 x 1.44	.53	3.90	.53	4.75	.32	19	24	17	19	24	17
<b>1154</b>	.625	1.00	.188 x .188 x 1.25	.6250	.188 x .188 x 1.50	.59	4.61	.51	5.42	.30	24	29	22	24	29	22
<b>1175</b>	1.000	1.44	.250 x .250 x 2.50	.6250	.188 x .188 x 1.50	.69	4.73	.49	5.50	.28	26	32	25	27	33	26
<b>1206</b>	1.438	1.94	.375 x .375 x 3.00	.6250	.188 x .188 x 1.50	.72	4.99	.61	6.00	.40	33	37	30	36	40	33
<b>1238</b>	1.438	1.94	.375 x .375 x 3.00	.7500	.188 x .188 x 1.75	.75	5.18	.51	6.00	.31	54	60	46	55	61	47
<b>1262</b>	1.438	1.94	.375 x .375 x 3.00	.7500	.188 x .188 x 1.75	.75	6.01	.60	7.00	.39	69	70	61	67	68	59
<b>1300</b>	1.938	2.51	.500 x .500 x 3.00	.8750	.188 x .188 x 1.75	.75	6.53	.60	7.50	.36	96	107	92	96	107	92
<b>1325</b>	1.938	2.51	.500 x .500 x 3.00	.8750	.188 x .188 x 1.75	.88	7.04	.54	7.88	.29	99	110	95	99	110	95
<b>1425</b>	2.188	2.75	.500 x .500 x 3.00	1.2500	.250 x .250 x 2.88	1.00	7.53	.63	8.50	.34	156	164	146	156	164	146
<b>1525</b>	3.438	4.26	.875 x .875 x 4.00	1.2500	.250 x .250 x 3.00	1.13	8.85	.97	10.50	.68	269	276	254	269	276	254
<b>1600</b>	3.438	4.18	.875 x .875 x 4.00	1.5000	.375 x .375 x 3.00	1.25	10.52	.52	11.50	.52	364	371	341	364	371	341
<b>1700</b>	3.938	4.92	1.000 x 1.000 x 7.00	1.6250	.375 x .375 x 2.87	1.42	11.36	1.09	13.50	1.09	...	470	440	...	470	440
<b>1800</b>	4.438	5.55	1.000 x 1.000 x 7.00	1.8750	.500 x .500 x 2.81	1.65	12.48	1.03	14.50	1.03	...	660	630	...	660	630
<b>11000</b>	5.438	6.67	1.250 x 1.250 x 12.00	2.2500	.500 x .500 x 3.69	1.65	15.78	1.39	18.50	1.39	...	...	980	...	...	980

# Assemblies \*

Reverse all arrows for opposite rotation of high speed shaft.

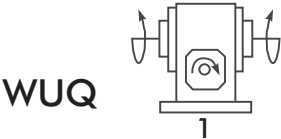
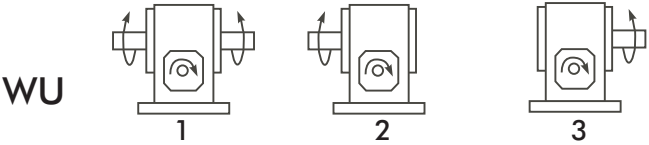
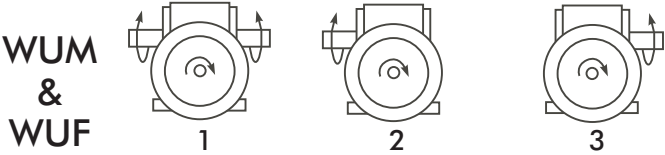

(See Page 5 for footnotes.)

# Motor Data

## NEMA Motor Flange Face Locations — Inches

DRIVE SIZE	56C/140TC		180TC		210TC		250TC	
	LA	LC	LB	LD	LB	LD	LB	LD
1133	3.46	6.07	...	...	...	...	...	...
1154	3.99	6.60	...	...	...	...	...	...
1175	4.09	6.70	...	...	...	...	...	...
1206	4.46	7.07	...	...	...	...	...	...
1238	4.63	7.76	5.06	8.76	...	8.76	...	...
1262	5.19	8.32	5.62	9.32	...	9.32	...	...
1300	5.69	8.82	6.12	9.82	6.56	9.82	...	...
1325	5.88	9.01	6.31	10.01	6.75	10.01	...	...
1425	6.45	11.81	7.21	12.90	7.21	12.90	7.77	13.46
1525	7.85	13.21	8.61	14.30	8.61	14.30	9.17	14.86
1600	10.45	...	9.33	15.88	9.33	15.88	9.94	16.50
1700	...	...	...	15.50	...	15.50	...	15.50
1800	...	...	...	...	...	16.58	...	16.58

## NEMA Motor Mounting Dimensions — Inches

FRAME SIZE	AJ	AK	BA	BB	BD	BF	BG	UA	Keyway
56C	5.88	4.50	.38	...	5.88	.41	6.64	.625	.1875 x .0938
140TC	5.88	4.50	.38	...	5.88	.41	6.64	.875	.1875 x .0938
180TC	7.25	8.50	...	.50	9.00	.53	...	1.125	.2500 x .1250
210TC	7.25	8.50	...	.50	9.00	.53	...	1.375	.3125 x .1562
250TC	7.25	8.50	...	.50	9.00	.53	...	1.625	.3750 x .1875

## IEC B5 & B3/B5 Motor Flange Dimensions \* — Inches

DRIVE SIZE	D63D	D71D	D80D	D90D	D100LD/D112MD	D132D
	LA	LA	LA	LA	LA	LA
1333	2.62	2.65	2.89	...	...	...
1154	3.15	3.18	3.42	...	...	...
1175	3.25	3.28	3.52	...	...	...
1206	3.62	3.65	3.89	...	...	...
1238	...	3.72	4.34	...	...	...
1262	...	4.28	4.90	4.90	5.30	...
1300	...	4.78	5.41	5.41	5.80	...
1325	...	4.97	5.59	5.59	5.99	...
1425	...	...	...	6.38	6.39	7.17
1525	...	...	...	7.78	7.78	8.57

## IEC B5 & B3/B5 Metric Motor Mounting Dimensions — Millimeters

FRAME SIZE	AJ	AK	BA	BD	BF	BG	UA	Keyway
D63D	115	95	10	117	M8 x 1.25	131	11	4 x 2.0
D71D	130	110	11	132	M8 x 1.25	146	14	5 x 2.5
D80D	165	130	15	165	M10 x 1.50	184	19	6 x 3.0
D90D	165	130	15	165	M10 x 1.50	184	24	8 x 3.5
D100LD/D112MD	215	180	18	216	M12 x 1.75	237	28	8 x 3.5
D132D	265	230	18	267	M12 x 1.75	290	38	10 x 4.0

(See Page 5 for footnotes.)

# Single Reduction/Vertical Output

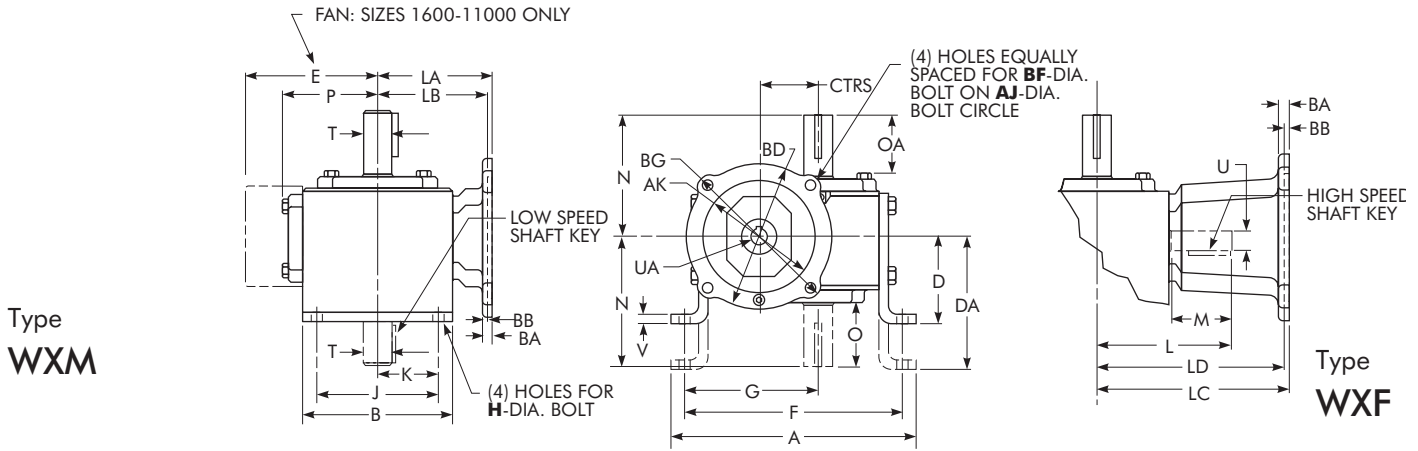

Type  
**WXM**

Type  
**WXF**

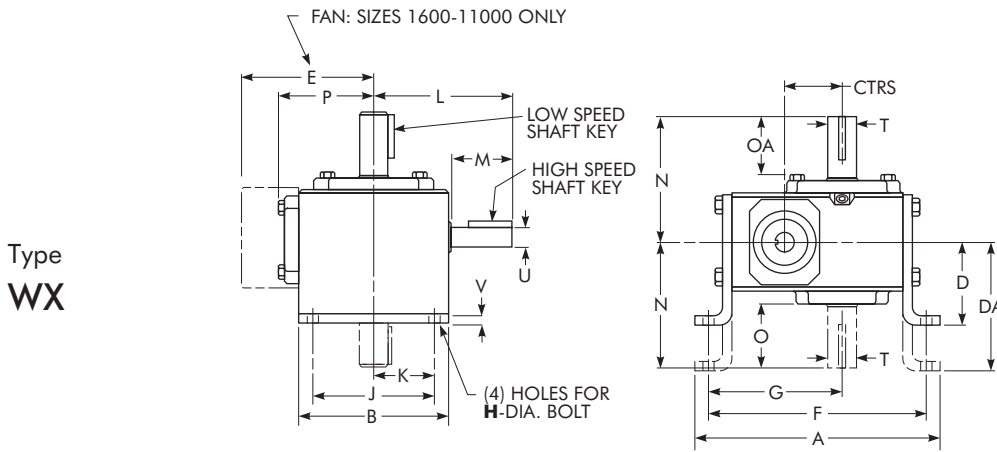

Type  
**WX**

SEE PAGE 43 FOR MOTOR MOUNTING DIMENSIONS.

(Continued on next page)

DRIVE SIZE ★	CTRS	A	B	D	E	F	G	H	J	K	L	M •	N	O •	OA •	P	Low Speed Shaft	
																	T	Key
																	-.0005 -.0015	
1133	1.33	7.26	4.00	2.63	...	6.50	3.86	.38	3.00	1.50	3.82	1.76	4.00	2.16	1.94	2.61	.6250	.188 x .188 x 1.50
1154	1.54	7.88	5.00	3.00	...	7.00	4.28	.44	4.00	2.00	4.35	1.76	4.31	2.11	1.90	3.14	.7500	.188 x .188 x 1.50
1175	1.75	8.25	5.00	3.00	...	7.37	4.50	.44	4.00	2.00	4.45	1.76	4.31	2.05	1.84	3.24	.8750	.188 x .188 x 1.38
1206	2.06	9.38	6.00	3.13	...	8.38	5.09	.50	4.88	2.44	4.82	1.76	4.68	2.29	2.08	3.61	1.0000	.250 x .250 x 1.44
1238	2.38	9.94	6.00	3.38	...	8.81	5.38	.50	4.88	2.44	5.51	2.38	5.14	2.66	2.44	3.77	1.1250	.250 x .250 x 1.75
1262	2.63	11.24	7.00	3.63	...	10.12	6.12	.56	5.75	2.88	6.07	2.38	5.63	2.73	2.52	4.34	1.1250	.250 x .250 x 1.44
1300	3.00	12.50	8.00	3.94	...	11.13	6.75	.56	6.00	3.00	6.57	2.38	6.75	3.60	3.36	4.84	1.2500	.250 x .250 x 2.25
1325	3.25	13.00	8.50	4.69	...	11.88	7.13	.56	6.13	3.06	6.76	2.38	7.06	3.66	3.42	5.02	1.3750	.313 x .313 x 2.50
1425	4.25	16.26	10.00	5.00	...	14.88	8.69	.69	7.88	3.94	9.57	3.47	8.12	4.50	4.21	6.10	1.8750	.500 x .500 x 3.06
1525	5.25	19.62	13.00	5.16	...	18.00	10.88	.78	10.00	5.00	10.88	3.38	9.06	4.78	4.53	7.50	2.0000	.500 x .500 x 3.50
1600	6.00	23.26	14.75	7.31	11.13	20.88	12.19	.91	11.76	5.88	11.78	3.41	10.00	4.66	4.66	...	2.2500	.500 x .500 x 4.00
1700	7.00	26.91	14.88	7.00	11.37	23.99	13.87	1.13	12.50	6.25	11.50	2.97	11.76	5.69	5.69	...	2.7500	.625 x .625 x 4.00
1800	8.00	28.96	17.00	8.00	12.52	25.50	14.38	1.13	14.00	7.00	12.50	2.84	12.25	6.02	6.02	...	3.0000	.750 x .750 x 4.50
11000	10.00	37.47	20.88	9.00	14.69	30.75	17.76	1.44	17.75	8.88	15.50	3.76	14.75	6.80	6.80	...	3.7500	.875 x .875 x 5.00

(See Page 5 for footnotes.)





# Assemblies \*

Reverse all arrows for opposite rotation of high speed shaft.

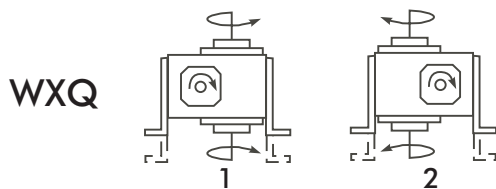
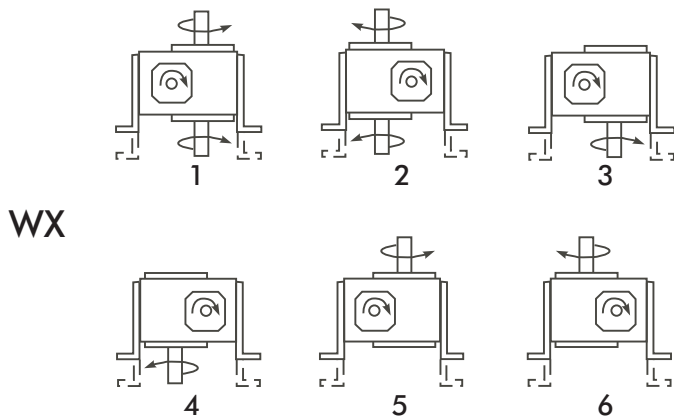
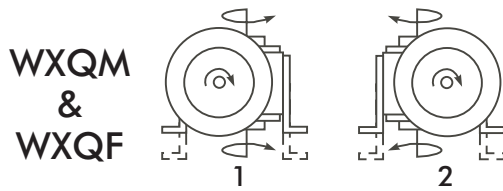
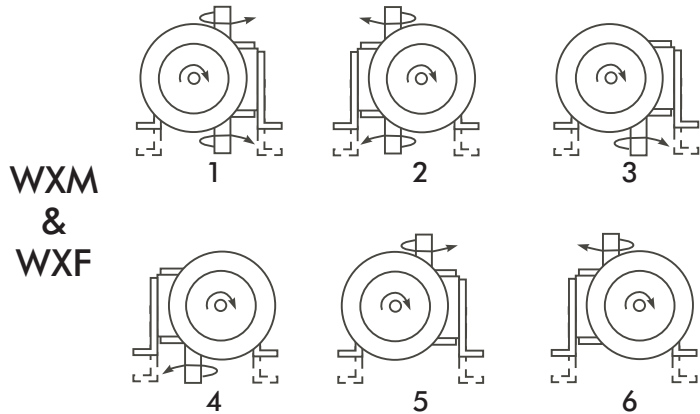

(See Page 5 for footnotes.)

# Motor Data

## NEMA Motor Flange Face Locations — Inches

DRIVE SIZE	56C/140TC		180TC		210TC		250TC	
	LA	LC	LB	LD	LB	LD	LB	LD
1133	3.46	6.07	...	...	...	...	...	...
1154	3.99	6.60	...	...	...	...	...	...
1175	4.09	6.70	...	...	...	...	...	...
1206	4.46	7.07	...	...	...	...	...	...
1238	4.63	7.76	5.06	8.76	...	8.76	...	...
1262	5.19	8.32	5.62	9.32	...	9.32	...	...
1300	5.69	8.82	6.12	9.82	6.56	9.82	...	...
1325	5.88	9.01	6.31	10.01	6.75	10.01	...	...
1425	6.45	11.81	7.21	12.90	7.21	12.90	7.77	13.46
1525	7.85	13.21	8.61	14.30	8.61	14.30	9.17	14.86
1600	10.45	...	9.33	15.88	9.33	15.88	9.94	16.50
1700	...	...	...	15.50	...	15.50	...	15.50
1800	...	...	...	...	...	16.58	...	16.58

## NEMA Motor Mounting Dimensions — Inches

FRAME SIZE	AJ	AK	BA	BB	BD	BF	BG	UA	Keyway
56C	5.88	4.50	.38	...	5.88	.41	6.64	.625	.1875 x .0938
140TC	5.88	4.50	.38	...	5.88	.41	6.64	.875	.1875 x .0938
180TC	7.25	8.50	...	.50	9.00	.53	...	1.125	.2500 x .1250
210TC	7.25	8.50	...	.50	9.00	.53	...	1.375	.3125 x .1562
250TC	7.25	8.50	...	.50	9.00	.53	...	1.625	.3750 x .1875

## IEC B5 & B3/B5 Motor Flange Dimensions \* — Inches

DRIVE SIZE	D63D	D71D	D80D	D90D	D100LD/D112MD	D132D
	LA	LA	LA	LA	LA	LA
1133	2.62	2.65	2.89	...	...	...
1154	3.15	3.18	3.42	...	...	...
1175	3.25	3.28	3.52	...	...	...
1206	3.62	3.65	3.89	...	...	...
1238	...	3.72	4.34	...	...	...
1262	...	4.28	4.90	4.90	5.30	...
1300	...	4.78	5.41	5.41	5.80	...
1325	...	4.97	5.59	5.59	5.99	...
1425	...	...	...	6.38	6.39	7.17
1525	...	...	...	7.78	7.78	8.57

## IEC B5 & B3/B5 Metric Motor Mounting Dimensions — Millimeters

FRAME SIZE	AJ	AK	BA	BD	BF	BG	UA	Keyway
D63D	115	95	10	117	M8 x 1.25	131	11	4 x 2.0
D71D	130	110	11	132	M8 x 1.25	146	14	5 x 2.5
D80D	165	130	15	165	M10 x 1.50	184	19	6 x 3.0
D90D	165	130	15	165	M10 x 1.50	184	24	8 x 3.5
D100LD/D112MD	215	180	18	216	M12 x 1.75	237	28	8 x 3.5
D132D	265	230	18	267	M12 x 1.75	290	38	10 x 4.0

(See Page 5 for footnotes.)

# Single Reduction/Vertical Input

Type  
**WJM**

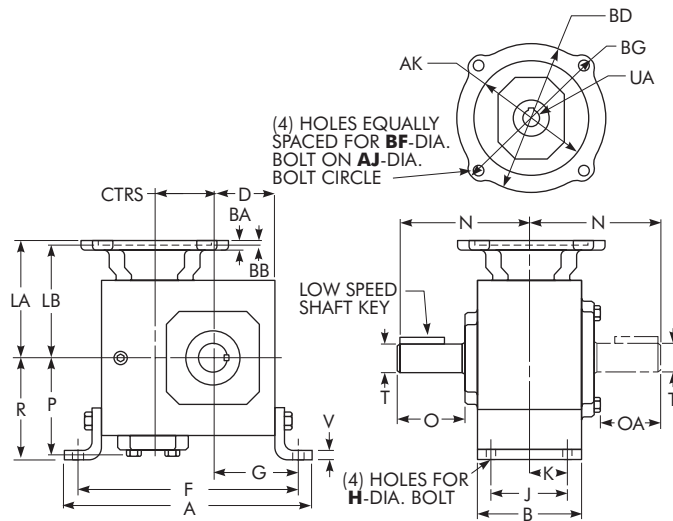

Type  
**WJF**

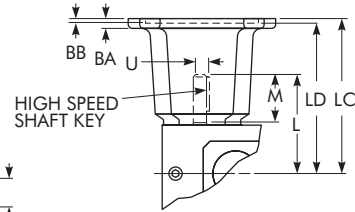

Type  
**WJ**

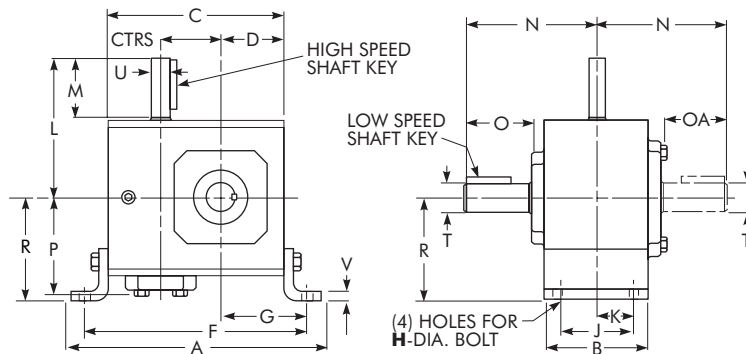

SEE PAGE 47 FOR MOTOR MOUNTING DIMENSIONS.

(Continued on next page)

DRIVE SIZE ★	CTRS	A	B	C	D	F	G	H	J	K	L	M •	N	O ♦	OA ♦	P	R
1133	1.33	7.42	2.75	4.66	1.72	6.42	2.60	.38	2.00	1.00	3.82	1.76	4.00	2.16	1.94	2.61	2.94
1154	1.54	8.14	3.50	5.38	1.91	7.08	2.76	.44	2.75	1.38	4.35	1.76	4.31	2.11	1.90	3.14	3.50
1175	1.75	8.51	3.50	5.75	2.06	7.45	2.91	.44	2.75	1.38	4.45	1.76	4.31	2.05	1.84	3.24	3.50
1206	2.06	9.76	4.00	6.38	2.28	8.62	3.40	.50	2.75	1.38	4.82	1.76	4.68	2.29	2.08	3.61	4.01
1238	2.38	10.31	4.00	6.94	2.50	9.19	3.63	.50	2.88	1.44	5.51	2.38	5.14	2.66	2.44	3.77	4.06
1262	2.63	11.62	5.00	8.00	2.94	10.38	4.13	.56	3.38	1.69	6.07	2.38	5.63	2.73	2.52	4.34	5.00
1300	3.00	12.64	6.00	8.88	3.25	11.38	4.50	.56	3.88	1.94	6.57	2.38	6.75	3.60	3.36	4.84	5.62
1325	3.25	13.14	6.00	9.38	3.50	11.88	4.75	.56	3.88	1.94	6.76	2.38	7.06	3.66	3.42	5.02	5.63
1425	4.25	16.38	7.00	11.38	4.44	14.88	6.19	.69	5.00	2.50	9.57	3.47	8.12	4.50	4.21	6.10	6.50
1525	5.25	19.00	7.00	14.00	5.12	17.50	6.87	.69	5.81	2.91	10.88	3.38	9.06	4.78	4.53	7.50	7.75

(See Page 5 for footnotes.)

Type  
**WJQM**

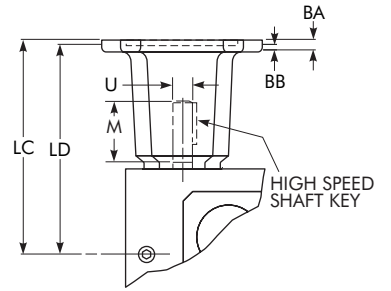
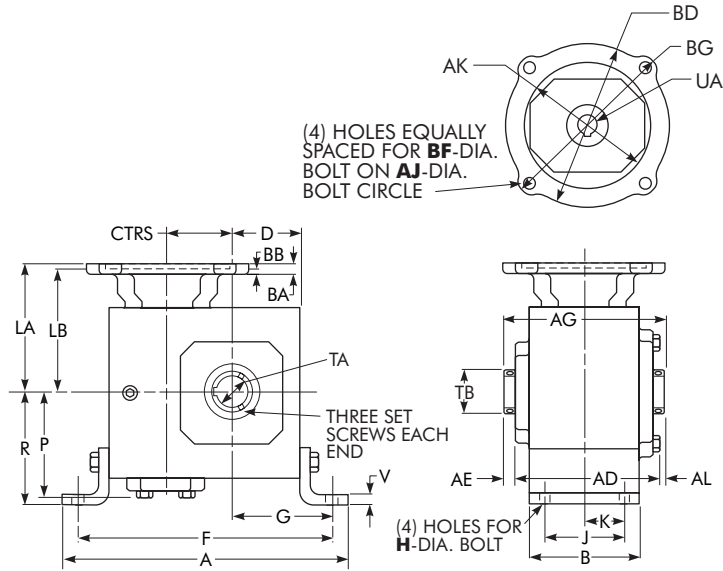

Type  
**WJQF**

Type  
**WJQ**

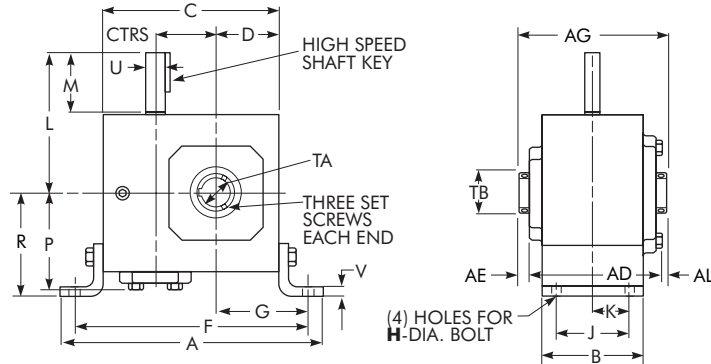

SEE PAGE 47 FOR MOTOR MOUNTING DIMENSIONS.

(Continued from preceding page)

DRIVE SIZE ★	Low Speed Shaft		Hollow Low Speed Shaft			High Speed Shaft		V	AD	AE	AG	AL	Approx. Wt - lb					
	T -.0005 -.0015	Key	TA Max = +.002 -.000	TB	Key	U -.0005 -.0015	Key						WJM	WJF	WJ	WJQM	WJQF	WJQ
<b>1133</b>	.6250	.188 x .188 x 1.50	.625	1.00	.188 x .188 x 1.25	.500	.125 x .125 x 1.44	.25	3.90	.53	4.75	.32	18	22	15	18	22	15
<b>1154</b>	.7500	.188 x .188 x 1.50	.625	1.00	.188 x .188 x 1.25	.625	.188 x .188 x 1.50	.25	4.61	.51	5.42	.30	24	29	22	24	29	22
<b>1175</b>	.8750	.188 x .188 x 1.38	1.000	1.44	.250 x .250 x 2.50	.625	.188 x .188 x 1.50	.25	4.73	.49	5.50	.28	26	31	24	27	32	25
<b>1206</b>	1.0000	.250 x .250 x 1.44	1.438	1.94	.375 x .375 x 3.00	.625	.188 x .188 x 1.50	.38	4.99	.61	6.00	.40	33	37	30	36	40	33
<b>1238</b>	1.1250	.250 x .250 x 1.75	1.438	1.94	.375 x .375 x 3.00	.750	.188 x .188 x 1.75	.38	5.18	.51	6.00	.31	49	50	41	50	51	42
<b>1262</b>	1.1250	.250 x .250 x 1.44	1.438	1.94	.375 x .375 x 3.00	.750	.188 x .188 x 1.75	.38	6.01	.60	7.00	.39	63	64	55	61	62	53
<b>1300</b>	1.2500	.250 x .250 x 2.25	1.938	2.51	.500 x .500 x 3.00	.875	.188 x .188 x 1.75	.38	6.53	.60	7.50	.36	86	97	82	86	97	82
<b>1325</b>	1.3750	.313 x .313 x 2.50	1.938	2.51	.500 x .500 x 3.00	.875	.188 x .188 x 1.75	.38	7.04	.54	7.88	.29	89	100	85	89	100	85
<b>1425</b>	1.8750	.500 x .500 x 3.06	2.188	2.75	.500 x .500 x 3.00	1.250	.250 x .250 x 2.88	.50	7.53	.63	8.50	.34	157	165	177	157	165	177
<b>1525</b>	2.0000	.500 x .500 x 3.50	3.438	4.26	.875 x .875 x 4.00	1.250	.250 x .250 x 3.00	.50	8.85	.97	10.50	.68	265	272	250	265	272	250

# Assemblies \*

Reverse all arrows for opposite rotation of high speed shaft. Refer to assembly A or B for low speed shaft rotation relative to high speed shaft position.

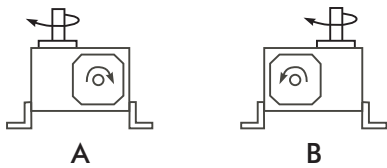
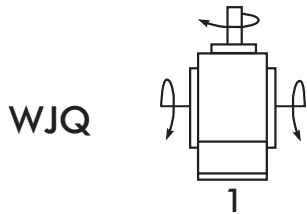
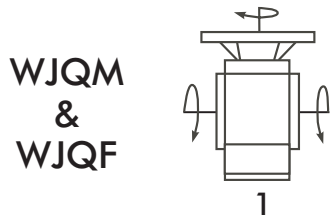
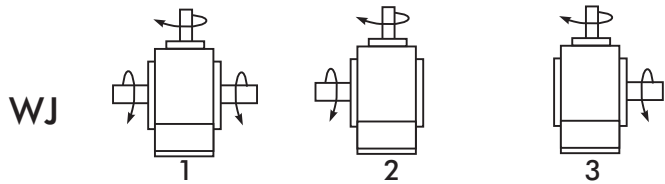
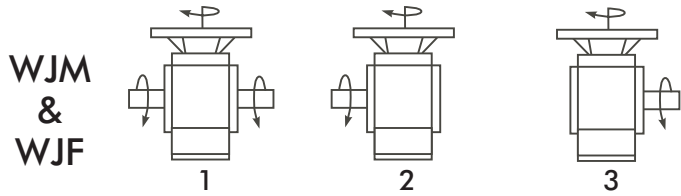

(See Page 5 for footnotes.)

# Motor Data

## NEMA Motor Flange Face Locations — Inches

DRIVE SIZE	56C/140TC		180TC		210TC		250TC	
	LA	LC	LB	LD	LB	LD	LB	LD
1133	3.46	6.07	...	...	...	...	...	...
1154	3.99	6.60	...	...	...	...	...	...
1175	4.09	6.70	...	...	...	...	...	...
1206	4.46	7.07	...	...	...	...	...	...
1238	4.63	7.76	5.06	8.76	...	8.76	...	...
1262	5.19	8.32	5.62	9.32	...	9.32	...	...
1300	5.69	8.82	6.12	9.82	6.56	9.82	...	...
1325	5.88	9.01	6.31	10.01	6.75	10.01	...	...
1425	6.45	11.81	7.21	12.90	7.21	12.90	7.77	13.46
1525	7.85	13.21	8.61	14.30	8.61	14.30	9.17	14.86

## NEMA Motor Mounting Dimensions — Inches

FRAME SIZE	AJ	AK	BA	BB	BD	BF	BG	UA	Keyway
56C	5.88	4.50	.38	...	5.88	.41	6.64	.625	.1875 x .0938
140TC	5.88	4.50	.38	...	5.88	.41	6.64	.875	.1875 x .0938
180TC	7.25	8.50	...	.50	9.00	.53	...	1.125	.2500 x .1250
210TC	7.25	8.50	...	.50	9.00	.53	...	1.375	.3125 x .1562
250TC	7.25	8.50	...	.50	9.00	.53	...	1.625	.3750 x .1875

## IEC B5 & B3/B5 Motor Flange Dimensions \* — Inches

DRIVE SIZE	D63D	D71D	D80D	D90D	D100LD/D112MD	D132D
	LA	LA	LA	LA	LA	LA
1133	2.62	2.65	2.89	...	...	...
1154	3.15	3.18	3.42	...	...	...
1175	3.25	3.28	3.52	...	...	...
1206	3.62	3.65	3.89	...	...	...
1238	...	3.72	4.34	...	...	...
1262	...	4.28	4.90	4.90	5.30	...
1300	...	4.78	5.41	5.41	5.80	...
1325	...	4.97	5.59	5.59	5.99	...
1425	...	...	...	6.38	6.39	7.17
1525	...	...	...	7.78	7.78	8.57

## IEC B5 & B3/B5 Metric Motor Mounting Dimensions — Millimeters

FRAME SIZE	AJ	AK	BA	BD	BF	BG	UA	Keyway
D63D	115	95	10	117	M8 x 1.25	131	11	4 x 2.0
D71D	130	110	11	132	M8 x 1.25	146	14	5 x 2.5
D80D	165	130	15	165	M10 x 1.50	184	19	6 x 3.0
D90D	165	130	15	165	M10 x 1.50	184	24	8 x 3.5
D100LD/D112MD	215	180	18	216	M12 x 1.75	237	28	8 x 3.5
D132D	265	230	18	267	M12 x 1.75	290	38	10 x 4.0

(See Page 5 for footnotes.)

# Single Reduction/Flanged Output

Type  
WLM

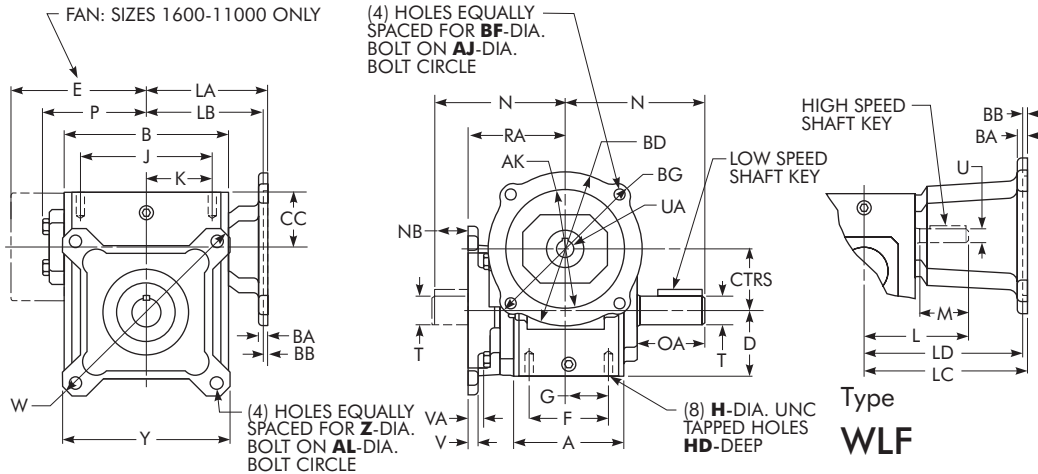

Type  
WLF

Type  
WL

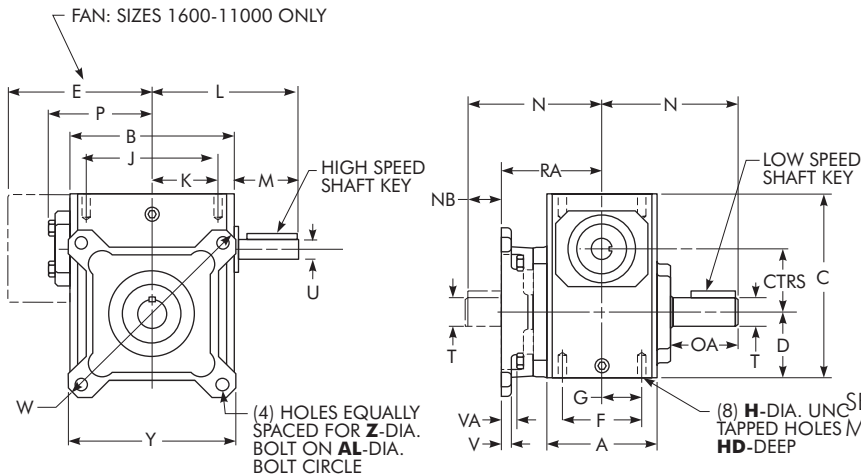

SEE PAGE 51 FOR MOTOR MOUNTING DIMENSIONS.

(Continued on next page)

DRIVE SIZE ★	CTRS	A	B	C	D	E	F	G	H	HD	J	K	L	M	N	OA	P	R	Low Speed Shaft	
																			T	Key
																			-.0005 -.0015	
1133	1.33	2.82	3.80	4.66	1.72	...	2.00	1.00	.3125-18	.50	3.25	1.63	3.82	1.76	4.00	2.16	2.61	4.90	.6250	.188 x .188 x 1.50
1154	1.54	3.44	4.88	5.38	1.91	...	2.75	1.38	.3125-18	.63	4.19	2.09	4.35	1.76	4.31	2.11	3.14	5.59	.7500	.188 x .188 x 1.50
1175	1.75	3.56	5.06	5.75	2.06	...	2.75	1.38	.3125-18	.63	4.19	2.09	4.45	1.76	4.31	2.05	3.24	5.94	.8750	.188 x .188 x 1.38
1206	2.06	3.81	5.80	6.38	2.28	...	3.00	1.50	.3125-18	.63	4.75	2.38	4.82	1.76	4.68	2.29	3.61	6.69	1.0000	.250 x .250 x 1.44
1238	2.38	4.06	6.12	6.94	2.50	...	2.88	1.44	.3750-16	.56	5.00	2.50	5.51	2.38	5.14	2.66	3.77	6.73	1.1250	.250 x .250 x 1.75
1262	2.63	4.84	7.12	8.00	2.94	...	3.38	1.69	.3750-16	.69	6.38	3.19	6.07	2.38	5.63	2.73	4.34	7.20	1.1250	.250 x .250 x 1.44
1300	3.00	5.25	8.12	8.88	3.25	...	4.00	2.00	.4375-14	.88	7.00	3.50	6.57	2.38	6.75	3.60	4.84	7.53	1.2500	.250 x .250 x 2.25
1325	3.25	5.75	8.50	9.38	3.50	...	4.00	2.00	.4375-14	.88	7.50	3.75	6.76	2.38	7.06	3.66	5.02	7.97	1.3750	.313 x .313 x 2.50
1425	4.25	6.13	10.25	11.38	4.44	...	5.00	2.50	.6250-11	1.00	8.50	4.25	9.57	3.47	8.12	4.50	6.10	8.81	1.8750	.500 x .500 x 3.06
1525	5.25	7.19	13.00	14.00	5.12	...	5.81	2.91	.6250-11	1.25	11.00	5.50	10.88	3.38	9.06	4.78	7.50	10.87	2.0000	.500 x .500 x 3.50
1600	6.00	8.13	14.25	16.50	6.50	11.13	6.38	3.19	.6250-11	1.00	12.75	6.38	11.78	3.41	10.00	4.65	...	13.01	2.2500	.500 x .500 x 4.00
1700	7.00	7.63	14.88	18.91	7.59	11.37	5.50	2.75	1.0000-8	1.56	12.50	6.25	11.50	2.97	11.76	5.65	...	14.20	2.7500	.625 x .625 x 4.00
1800	8.00	8.63	17.00	20.96	8.86	12.52	6.50	3.25	1.0000-8	1.66	14.25	7.13	12.50	2.84	12.25	5.98	...	15.59	3.0000	.750 x .750 x 4.50
11000	10.00	9.53	20.88	25.47	10.36	14.69	6.88	3.44	1.2500-7	2.04	17.75	8.88	15.50	3.76	14.75	6.76	...	18.32	3.7500	.875 x .875 x 5.00

(See Page 5 for footnotes.)



Type  
**WLQM**

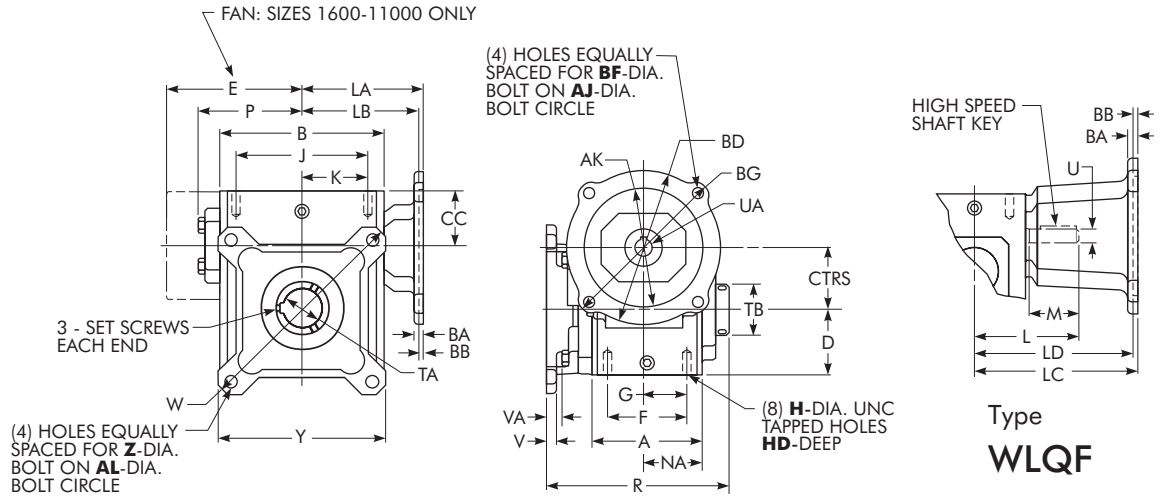

Type  
**WLQ**

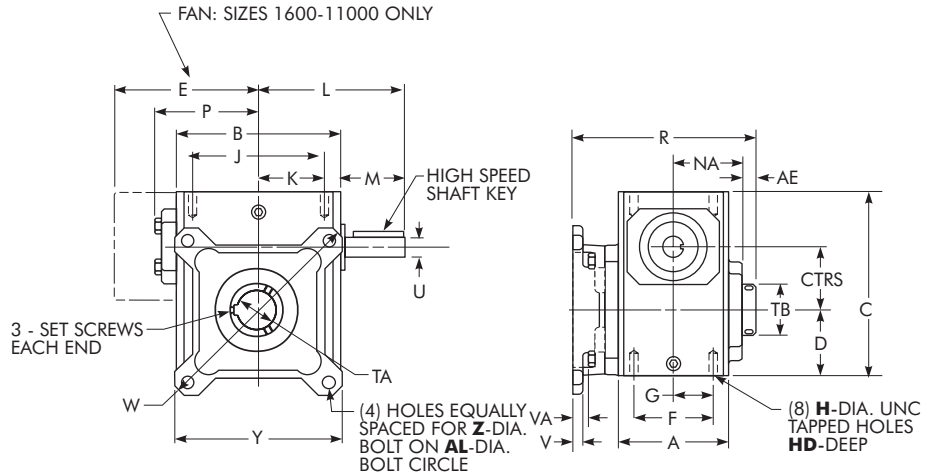

SEE PAGE 51 FOR MOTOR MOUNTING DIMENSIONS.

(Continued from preceding page)

DRIVE	Hollow Low Speed Shaft			High Speed Shaft		V	W	Y	Z	AE	AL	CC	NA	NB	RA	VA	Approx. Wt - lb						
	TA Max = +.002 -.000	TB	Key	U -.0005 -.0015	Key												WLM	WLF	WL	WLQM	WLQF	WLQ	
<b>1133</b>	.625	1.00	.188 x .188 x 1.25	.5000	.125 x .125 x 1.44	.38	5.92	4.50	.34	.53	5.00	4.66	2.38	1.48	2.52	.08	19	24	17	18	22	15	
<b>1154</b>	.625	1.00	.188 x .188 x 1.25	.6250	.188 x .188 x 1.50	.38	5.92	4.50	.34	.51	5.00	5.38	2.71	1.44	2.87	.08	24	29	22	24	29	22	
<b>1175</b>	1.000	1.44	.250 x .250 x 2.50	.6250	.188 x .188 x 1.50	.38	6.64	5.00	.34	.49	5.88	5.75	2.75	1.13	3.18	.11	26	32	25	27	33	26	
<b>1206</b>	1.438	1.94	.375 x .375 x 3.00	.6250	.188 x .188 x 1.50	.44	7.88	5.99	.41	.61	7.00	6.38	3.00	.99	3.69	.55	34	38	31	34	40	32	
<b>1238</b>	1.438	1.94	.375 x .375 x 3.00	.7500	.188 x .188 x 1.75	.44	8.39	6.27	.41	.51	7.50	6.94	3.00	1.47	3.67	.51	56	62	48	52	57	49	
<b>1262</b>	1.438	1.94	.375 x .375 x 3.00	.7500	.188 x .188 x 1.75	.50	8.88	6.67	.41	.60	8.00	8.00	3.50	1.99	3.64	.04	69	71	61	62	67	59	
<b>1300</b>	1.938	2.51	.500 x .500 x 3.00	.8750	.188 x .188 x 1.75	.50	9.89	7.37	.41	.60	9.00	8.88	3.75	3.03	3.72	.07	96	107	92	96	107	92	
<b>1325</b>	1.938	2.51	.500 x .500 x 3.00	.8750	.188 x .188 x 1.75	.50	9.89	7.37	.41	.54	9.00	9.38	3.94	3.08	3.98	.07	99	110	95	99	110	95	
<b>1425</b>	2.188	2.75	.500 x .500 x 3.00	1.2500	.250 x .250 x 2.88	.62	12.95	9.65	.56	.63	11.50	11.38	4.25	3.62	4.50	.06	152	166	148	158	166	148	
<b>1525</b>	3.438	4.26	.875 x .875 x 4.00	1.2500	.250 x .250 x 3.00	.75	15.50	11.75	.69	.97	14.00	14.00	5.25	3.50	5.56	.34	265	272	250	265	272	250	
<b>1600</b>	3.438	4.18	.875 x .875 x 4.00	1.5000	.375 x .375 x 3.00	.75	18.00	6.87	.69	.52	15.63	16.50	5.75	2.78	7.22	1.38	356	363	333	356	363	333	
<b>1700</b>	3.938	4.92	1.000 x 1.000 x 7.00	1.6250	.375 x .375 x 2.87	.75	21.00	7.82	.78	1.09	18.38	18.91	6.75	4.32	7.44	1.57	...	444	414	...	444	414	
<b>1800</b>	4.438	5.55	1.000 x 1.000 x 7.00	1.8750	.500 x .500 x 2.81	.75	24.00	8.94	1.03	1.03	21.00	20.96	7.25	3.92	8.33	1.89	...	630	600	...	630	600	
<b>11000</b>	5.438	6.67	1.250 x 1.250 x 12.00	2.2500	.500 x .500 x 3.69	1.00	29.00	10.60	1.03	1.39	25.00	25.47	9.25	5.70	9.05	1.85	...	...	925	...	...	...	925

# Assemblies \*

Reverse all arrows for opposite rotation of high speed shaft.

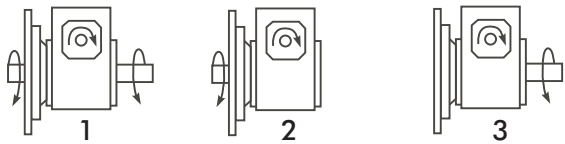
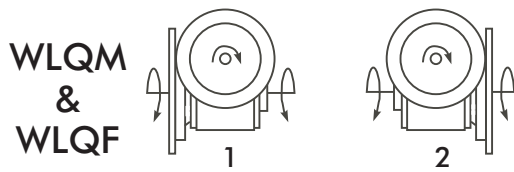
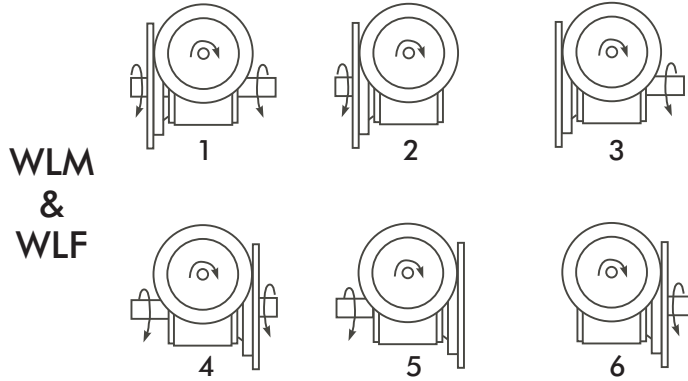

**WL**

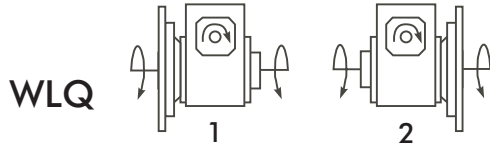
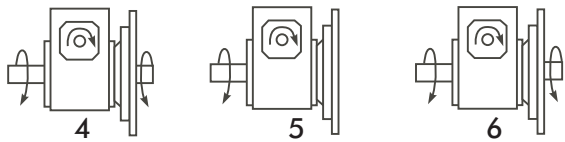

(See Page 5 for footnotes.)

# Motor Data

## NEMA Motor Flange Face Locations — Inches

DRIVE SIZE	56C/140TC		180TC		210TC		250TC	
	LA	LC	LB	LD	LB	LD	LB	LD
1133	3.46	6.07	...	...	...	...	...	...
1154	3.99	6.60	...	...	...	...	...	...
1175	4.09	6.70	...	...	...	...	...	...
1206	4.46	7.07	...	...	...	...	...	...
1238	4.63	7.76	5.06	8.76	...	8.76	...	...
1262	5.19	8.32	5.62	9.32	...	9.32	...	...
1300	5.69	8.82	6.12	9.82	6.56	9.82	...	...
1325	5.88	9.01	6.31	10.01	6.75	10.01	...	...
1425	6.45	11.81	7.21	12.90	7.21	12.90	7.77	13.46
1525	7.85	13.21	8.61	14.30	8.61	14.30	9.17	14.86
1600	10.45	...	9.33	15.88	9.33	15.88	9.94	16.50
1700	...	...	...	15.50	...	15.50	...	15.50
1800	...	...	...	...	...	16.58	...	16.58

## NEMA Motor Mounting Dimensions — Inches

FRAME SIZE	AJ	AK	BA	BB	BD	BF	BG	UA	Keyway
56C	5.88	4.50	.38	...	5.88	.41	6.64	.625	.1875 x .0938
140TC	5.88	4.50	.38	...	5.88	.41	6.64	.875	.1875 x .0938
180TC	7.25	8.50	...	.50	9.00	.53	...	1.125	.2500 x .1250
210TC	7.25	8.50	...	.50	9.00	.53	...	1.375	.3125 x .1562
250TC	7.25	8.50	...	.50	9.00	.53	...	1.625	.3750 x .1875

## IEC B5 & B3/B5 Motor Flange Dimensions \* — Inches

DRIVE SIZE	D63D	D71D	D80D	D90D	D100LD/D112MD	D132D
	LA	LA	LA	LA	LA	LA
1133	2.62	2.65	2.89	...	...	...
1154	3.15	3.18	3.42	...	...	...
1175	3.25	3.28	3.52	...	...	...
1206	3.62	3.65	3.89	...	...	...
1238	...	3.72	4.34	...	...	...
1262	...	4.28	4.90	4.90	5.30	...
1300	...	4.78	5.41	5.41	5.80	...
1325	...	4.97	5.59	5.59	5.99	...
1425	...	...	...	6.38	6.39	7.17
1525	...	...	...	7.78	7.78	8.57

## IEC B5 & B3/B5 Metric Motor Mounting Dimensions — Millimeters

FRAME SIZE	AJ	AK	BA	BD	BF	BG	UA	Keyway
D63D	115	95	10	117	M8 x 1.25	131	11	4 x 2.0
D71D	130	110	11	132	M8 x 1.25	146	14	5 x 2.5
D80D	165	130	15	165	M10 x 1.50	184	19	6 x 3.0
D90D	165	130	15	165	M10 x 1.50	184	24	8 x 3.5
D100LD/D112MD	215	180	18	216	M12 x 1.75	237	28	8 x 3.5
D132D	265	230	18	267	M12 x 1.75	290	38	10 x 4.0

(See Page 5 for footnotes.)

# Quick Selection Tables/Double Reduction

## Worm-Worm

### 1.00 Service Factor

Ratio	Output rpm	Motor Horsepower @ 1750 rpm													
		1/6	1/4	1/3	1/2	3/4	1	1 1/2	2	3	5	7 1/2	10	15	20
75	23.3	1133	1154	1175	1206	1238	1262	1300	1425	1525	1525	1600	1800	1800	11000
100	17.5	1154	1154	1206	1238	1262	1300	1325	1425	1525	1525	1600	1800	11000	11000
150	11.7	1154	1206	1238	1262	1300	1325	1425	1425	1525	1600	1700	1800	11000	
200	8.75	1206	1206	1238	1262	1300	1325	1425	1425	1525	1700	1800	11000		
250	7.00	1206	1238	1238	1300	1325	1425	1425	1525	1525	1700	11000	11000		
300	5.83	1206	1238	1262	1300	1325	1425	1425	1525	1600	1800	11000	11000		
400	4.38	1238	1262	1300	1325	1425	1425	1525	1525	1700	11000	11000			
500	3.50	1238	1262	1300	1325	1425	1425	1525	1600	1800	11000				
600	2.92	1238	1300	1300	1325	1425	1525	1525	1600	1800	11000				
750	2.33	1262	1300	1325	1425	1425	1525	1600	1700	11000	11000				
900	1.94	1300	1300	1325	1425	1525	1525	1600	1800	11000					
1000	1.75	1300	1300	1325	1425	1525	1525	1600	1800	11000					
1200	1.46	1300	1325	1425	1425	1525	1525	1700	1800	11000					
1500	1.17	1300	1325	1425	1525	1525	1600	1800	11000	11000					
1800	.972	1300	1325	1425	1525	1525	1600	11000	11000						
2400	.729	1325	1425	1425	1525	1600	1800	11000	11000						
3000	.583	1325	1425	1525	1525	1700	1800	11000							
3600	.486	1425	1525	1525	1525	1800	11000	11000							

## Worm- Worm

### 1.25 Service Factor

Ratio	Output rpm	Motor Horsepower @ 1750 rpm													
		1/6	1/4	1/3	1/2	3/4	1	1 1/2	2	3	5	7 1/2	10	15	20
75	23.3	1154	1154	1206	1238	1262	1300	1425	1425	1525	1600	1700	1800	11000	11000
100	17.5	1154	1206	1206	1238	1300	1300	1425	1425	1525	1600	1700	1800	11000	
150	11.7	1206	1206	1238	1262	1300	1325	1425	1525	1525	1700	1800	11000		
200	8.75	1206	1238	1262	1300	1325	1425	1425	1525	1525	1800	11000	11000		
250	7.00	1238	1238	1262	1300	1425	1425	1525	1525	1600	1800	11000			
300	5.83	1238	1262	1300	1325	1425	1425	1525	1525	1700	11000	11000			
400	4.38	1238	1300	1300	1425	1425	1525	1525	1600	1800	11000				
500	3.50	1262	1300	1325	1425	1425	1525	1525	1700	1800	11000				
600	2.92	1262	1300	1325	1425	1525	1525	1600	1700	11000	11000				
750	2.33	1300	1300	1325	1425	1525	1525	1600	1800	11000					
900	1.94	1300	1325	1425	1425	1525	1525	1800	1800	11000					
1000	1.75	1300	1325	1425	1525	1525	1600	1800	11000	11000					
1200	1.46	1300	1325	1425	1525	1525	1600	1800	11000						
1500	1.17	1300	1425	1425	1525	1600	1700	11000	11000						
1800	.972	1325	1425	1425	1525	1600	1800	11000	11000						
2400	.729	1425	1425	1525	1525	1800	11000	11000							
3000	.583	1425	1525	1525	1600	1800	11000								
3600	.486	1425	1525	1525	1600	11000	11000								

# Quick Selection Tables/Double Reduction

## Worm-Worm

### 1.50 Service Factor

Ratio	Output rpm	Motor Horsepower @ 1750 rpm												
		1/6	3	a	2	:	1	12	2	3	5	7.5	10	15
75	23.3	1154	1206	1206	1238	1300	1300	1425	1525	1525	1600	1800	1800	11000
100	17.5	1154	1206	1238	1262	1300	1325	1425	1525	1525	1600	1800	11000	11000
150	11.7	1206	1238	1238	1300	1325	1425	1425	1525	1600	1700	11000	11000	
200	8.75	1206	1238	1262	1300	1425	1425	1525	1525	1600	1800	11000		
250	7.00	1238	1262	1300	1325	1425	1425	1525	1525	1700	11000	11000		
300	5.83	1238	1262	1300	1325	1425	1425	1525	1600	1800	11000			
400	4.38	1262	1300	1325	1425	1425	1525	1525	1700	1800	11000			
500	3.50	1262	1300	1325	1425	1525	1525	1600	1800	11000				
600	2.92	1300	1325	1325	1425	1525	1525	1700	1800	11000				
750	2.33	1300	1325	1425	1525	1525	1600	1800	11000	11000				
900	1.94	1300	1325	1425	1525	1525	1600	1800	11000					
1000	1.75	1300	1425	1425	1525	1525	1600	1800	11000					
1200	1.46	1325	1425	1425	1525	1600	1700	11000	11000					
1500	1.17	1325	1425	1525	1525	1600	1800	11000	11000					
1800	.972	1325	1425	1525	1525	1800	11000	11000						
2400	.729	1425	1525	1525	1600	1800	11000							
3000	.583	1425	1525	1525	1700	11000	11000							
3600	.486	1525	1525	1525	1800	11000	11000							

## Worm-Worm

### 1.75 Service Factor

Ratio	Output rpm	Motor Horsepower @ 1750 rpm												
		1/6	3	a	2	:	1	12	2	3	5	7½	10	15
75	23.3	1154	1206	1238	1238	1300	1425	1525	1525	1600	1600	1800	11000	11000
100	17.5	1206	1206	1238	1262	1300	1425	1525	1525	1600	1700	11000	11000	
150	11.7	1206	1238	1262	1300	1325	1425	1525	1525	1600	1800	11000		
200	8.75	1238	1262	1300	1325	1425	1425	1525	1525	1700	11000	11000		
250	7.00	1238	1300	1300	1425	1425	1525	1525	1600	1800	11000			
300	5.83	1238	1300	1300	1425	1425	1525	1525	1600	1800	11000			
400	4.38	1262	1300	1325	1425	1525	1525	1600	1800	11000				
500	3.50	1300	1325	1425	1425	1525	1525	1700	1800	11000				
600	2.92	1300	1325	1425	1425	1525	1600	1800	11000	11000				
750	2.33	1300	1325	1425	1525	1525	1600	1800	11000					
900	1.94	1300	1425	1425	1525	1600	1700	11000	11000					
1000	1.75	1325	1425	1425	1525	1600	1800	11000	11000					
1200	1.46	1325	1425	1525	1525	1600	1800	11000	11000					
1500	1.17	1425	1425	1525	1525	1800	11000	11000						
1800	.972	1425	1525	1525	1600	1800	11000							
2400	.729	1425	1525	1525	1700	11000	11000							
3000	.583	1425	1525	1525	1800	11000	11000							
3600	.486	1525	1525	1600	11000	11000								

# Horsepower and Torque Ratings/Double Reduction

## Worm-Worm

Nominal Ratio	SPEED (rpm)		SIZE 1133			SIZE 1154			SIZE 1175		
	Input	Approx. Output	Horsepower		Output Torque (lb-in)	Horsepower		Output Torque (lb-in)	Horsepower		Output Torque (lb-in)
			Input	Output		Input	Output		Input	Output	
75	1750	23.3	0.181	0.119	321	0.310	0.192	519	0.348	0.241	651
	1170	15.6	0.129	0.081	329	0.220	0.129	522	0.248	0.166	669
	870	11.6	0.100	0.061	333	0.173	0.098	531	0.192	0.125	678
100	1750	17.5	0.143	0.089	320	0.252	0.144	518	0.268	0.179	646
	1170	11.7	0.102	0.061	327	0.184	0.099	535	0.191	0.123	661
	870	8.70	0.079	0.045	330	0.145	0.075	544	0.148	0.092	669
150	1750	11.7	0.103	0.062	333	0.184	0.099	535	0.197	0.126	678
	1170	7.80	0.072	0.042	336	0.132	0.068	547	0.139	0.085	687
	870	5.80	0.056	0.031	338	0.104	0.051	553	0.108	0.064	692
200	1750	8.75	0.081	0.046	330	0.149	0.076	544	0.152	0.093	669
	1170	5.85	0.058	0.031	334	0.107	0.051	553	0.107	0.063	676
	870	4.35	0.045	0.023	336	0.084	0.039	558	0.083	0.047	681
250	1750	7	0.074	0.038	340	0.129	0.060	545	0.124	0.072	650
	1170	4.68	0.053	0.026	344	0.093	0.041	553	0.087	0.049	657
	870	3.48	0.041	0.019	346	0.073	0.031	558	0.068	0.036	660
300	1750	5.83	0.067	0.031	340	0.110	0.051	553	0.124	0.064	693
	1170	3.90	0.048	0.021	344	0.079	0.035	559	0.089	0.044	703
	870	2.90	0.037	0.016	346	0.062	0.026	562	0.069	0.033	707
400	1750	4.38	0.047	0.023	336	0.088	0.039	558	0.088	0.047	680
	1170	2.93	0.034	0.016	337	0.064	0.026	562	0.062	0.031	684
	870	2.18	0.026	0.012	338	0.05	0.019	565	0.049	0.024	686
500	1750	3.50	0.043	0.019	346	0.077	0.031	561	0.076	0.038	683
	1170	2.34	0.031	0.013	348	0.056	0.021	564	0.055	0.026	686
	870	1.74	0.025	0.010	349	0.044	0.016	566	0.043	0.019	688
600	1750	2.92	0.039	0.016	346	0.068	0.026	562	0.073	0.033	707
	1170	1.95	0.028	0.011	348	0.05	0.017	565	0.053	0.022	712
	870	1.45	0.022	0.008	349	0.04	0.013	567	0.042	0.016	714
750	1750	2.33	0.033	0.013	348	0.060	0.021	562	0.064	0.026	710
	1170	1.56	0.025	0.009	349	0.044	0.014	566	0.046	0.017	714
	870	1.16	0.020	0.006	350	0.035	0.010	567	0.037	0.013	716
900	1750	1.94	0.030	0.011	348	0.057	0.017	561	0.056	0.022	712
	1170	1.3	0.022	0.007	349	0.042	0.012	565	0.041	0.015	715
	870	.967	0.018	0.005	350	0.034	0.009	566	0.033	0.011	716
1000	1750	1.75	0.028	0.009	349	0.049	0.016	566	0.048	0.019	688
	1170	1.17	0.021	0.006	350	0.036	0.011	568	0.035	0.013	689
	870	.870	0.016	0.005	350	0.029	0.008	569	0.028	0.01	690
1200	1750	1.46	0.026	0.008	349	0.045	0.013	567	0.047	0.017	714
	1170	.975	0.019	0.005	350	0.033	0.009	569	0.034	0.011	716
	870	.725	0.015	0.004	350	0.027	0.007	569	0.027	0.008	718
1500	1750	1.17	0.022	0.006	350	0.04	0.01	567	0.041	0.013	716
	1170	.780	0.016	0.004	350	0.03	0.007	569	0.03	0.009	717
	870	.580	0.013	0.003	351	0.024	0.005	569	0.024	0.007	718
1800	1750	.972	0.020	0.005	350	0.038	0.008	566	0.037	0.011	716
	1170	.650	0.015	0.004	350	0.029	0.006	568	0.027	0.007	718
	870	.483	0.012	0.003	351	0.023	0.004	569	0.022	0.006	719
2400	1750	.729	0.017	0.004	337	0.033	0.006	563	0.029	0.008	683
	1170	.488	0.012	0.003	337	0.025	0.004	564	0.021	0.005	685
	870	.363	0.010	0.002	338	0.02	0.003	565	0.017	0.004	685
3000	1750	.583	0.015	0.003	317	0.029	0.005	544	0.023	0.006	640
	1170	.390	0.010	0.002	317	0.022	0.003	545	0.017	0.004	641
	870	.290	0.008	0.001	317	0.018	0.003	546	0.014	0.003	642
3600	1750	.486	0.012	0.002	303	0.026	0.004	514	0.020	0.005	608
	1170	.325	0.009	0.002	304	0.019	0.003	516	0.015	0.003	609
	870	.242	0.007	0.001	304	0.016	0.002	517	0.012	0.002	609

# Horsepower and Torque Ratings/Double Reduction

Worm-Worm

Nominal Ratio	SPEED (rpm)		SIZE 1206			SIZE 1238			SIZE 1262		
	Input	Approx. Output	Horsepower		Output Torque (lb-in)	Horsepower		Output Torque (lb-in)	Horsepower		Output Torque (lb-in)
			Input	Output		Input	Output		Input	Output	
75	1750	23.3	0.528	0.381	1028	0.870	0.628	1699	1.020	0.758	2047
	1170	15.6	0.376	0.261	1056	0.599	0.417	1684	0.724	0.522	2111
	870	11.6	0.291	0.197	1072	0.465	0.315	1712	0.561	0.395	2145
100	1750	17.5	0.450	0.306	1102	0.67	0.458	1650	0.900	0.632	2276
	1170	11.7	0.306	0.200	1076	0.482	0.316	1704	0.622	0.419	2258
	870	8.7	0.238	0.151	1091	0.376	0.239	1733	0.484	0.317	2297
150	1750	11.7	0.309	0.201	1086	0.500	0.326	1756	0.619	0.418	2259
	1170	7.8	0.210	0.134	1086	0.337	0.215	1740	0.439	0.286	2308
	870	5.8	0.163	0.101	1094	0.261	0.162	1755	0.341	0.215	2334
200	1750	8.75	0.250	0.156	1123	0.385	0.240	1732	0.520	0.334	2406
	1170	5.85	0.172	0.103	1106	0.273	0.163	1760	0.351	0.217	2334
	870	4.35	0.133	0.077	1113	0.212	0.123	1775	0.272	0.163	2353
250	1750	7	0.193	0.116	1042	0.330	0.196	1765	0.420	0.258	2323
	1170	4.68	0.136	0.078	1055	0.226	0.129	1730	0.286	0.169	2276
	870	3.48	0.105	0.059	1062	0.176	0.096	1744	0.222	0.127	2294
300	1750	5.83	0.177	0.102	1106	0.290	0.168	1816	0.380	0.227	2454
	1170	3.9	0.125	0.069	1116	0.200	0.110	1779	0.257	0.146	2359
	870	2.9	0.097	0.052	1121	0.155	0.082	1789	0.199	0.109	2373
400	1750	4.38	0.141	0.077	1113	0.224	0.123	1775	0.300	0.169	2432
	1170	2.92	0.101	0.052	1121	0.160	0.083	1789	0.206	0.110	2372
	870	2.18	0.078	0.039	1125	0.124	0.062	1796	0.159	0.082	2382
500	1750	3.50	0.122	0.062	1118	0.194	0.099	1783	0.249	0.131	2365
	1170	2.34	0.088	0.042	1124	0.139	0.067	1795	0.179	0.088	2380
	870	1.74	0.069	0.031	1127	0.110	0.050	1801	0.141	0.066	2388
600	1750	2.92	0.107	0.052	1121	0.174	0.083	1795	0.220	0.110	2372
	1170	1.95	0.078	0.035	1126	0.125	0.056	1809	0.159	0.074	2385
	870	1.45	0.062	0.026	1129	0.097	0.042	1817	0.126	0.055	2392
750	1750	2.33	0.093	0.042	1123	0.150	0.067	1804	0.180	0.086	2311
	1170	1.56	0.068	0.028	1129	0.109	0.045	1815	0.131	0.058	2323
	870	1.16	0.053	0.021	1132	0.086	0.034	1821	0.104	0.043	2329
900	1750	1.94	0.082	0.035	1126	0.133	0.056	1809	0.154	0.070	2261
	1170	1.30	0.060	0.023	1131	0.097	0.038	1819	0.112	0.047	2273
	870	.967	0.048	0.017	1134	0.077	0.028	1824	0.089	0.035	2278
1000	1750	1.75	0.076	0.031	1127	0.122	0.050	1801	0.156	0.066	2388
	1170	1.17	0.056	0.021	1130	0.089	0.034	1806	0.114	0.051	2396
	870	.870	0.044	0.016	1132	0.071	0.025	1809	0.090	0.033	2400
1200	1750	1.46	0.068	0.026	1130	0.110	0.042	1817	0.142	0.055	2392
	1170	.975	0.050	0.018	1134	0.081	0.028	1824	0.104	0.037	2398
	870	.725	0.040	0.013	1136	0.064	0.021	1828	0.083	0.028	2402
1500	1750	1.17	0.059	0.021	1132	0.095	0.034	1821	0.116	0.043	2329
	1170	.780	0.043	0.014	1135	0.070	0.023	1827	0.086	0.029	2335
	870	.580	0.034	0.011	1137	0.056	0.017	1830	0.068	0.021	2338
1800	1750	.972	0.054	0.018	1134	0.087	0.028	1824	0.100	0.035	2278
	1170	.650	0.040	0.012	1136	0.065	0.019	1829	0.074	0.024	2284
	870	.483	0.032	0.009	1137	0.052	0.014	1832	0.059	0.018	2287
2400	1750	.729	0.046	0.013	1120	0.073	0.021	1790	0.091	0.027	2374
	1170	.488	0.034	0.009	1123	0.054	0.014	1795	0.068	0.018	2380
	870	.363	0.027	0.007	1124	0.043	0.010	1797	0.054	0.014	2384
3000	1750	.583	0.036	0.009	1031	0.061	0.016	1698	0.075	0.021	2234
	1170	.390	0.027	0.006	1033	0.045	0.011	1703	0.055	0.014	2240
	870	.290	0.021	0.005	1034	0.036	0.008	1705	0.045	0.010	2242
3600	1750	.486	0.035	0.008	1031	0.046	0.012	1501	0.062	0.016	2073
	1170	.325	0.026	0.005	1034	0.034	0.008	1505	0.046	0.011	2078
	870	.242	0.021	0.004	1035	0.028	0.006	1507	0.037	0.008	2081

# Horsepower and Torque Ratings/Double Reduction

## Worm-Worm

Nominal Ratio	SPEED (rpm)		SIZE 1300			SIZE 1325			SIZE 1425		
	Input	Approx. Output	Horsepower		Output Torque (lb-in)	Horsepower		Output Torque (lb-in)	Horsepower		Output Torque (lb-in)
			Input	Output		Input	Output		Input	Output	
75	1750	23.3	1.610	1.190	3206	1.61	1.190	3214	2.51	1.92	5199
	1170	15.6	1.190	0.845	3412	1.32	0.933	3770	2.10	1.55	6273
	870	11.6	0.934	0.641	3483	1.09	0.749	4070	1.77	1.27	6891
100	1750	17.5	1.310	0.912	3284	1.610	1.140	4114	2.51	1.85	6653
	1170	11.7	0.950	0.635	3420	1.250	0.849	4574	2.10	1.48	7995
	870	8.70	0.746	0.482	3492	0.984	0.645	4675	1.77	1.21	8759
150	1750	11.7	0.970	0.644	3482	1.330	0.842	4547	2.39	1.690	9153
	1170	7.80	0.694	0.440	3552	0.984	0.588	4755	1.80	1.220	9866
	870	5.80	0.540	0.330	3589	0.781	0.448	4867	1.41	0.926	10058
200	1750	8.75	0.775	0.485	3491	1.020	0.649	4673	2.06	1.410	10156
	1170	5.85	0.556	0.331	3563	0.734	0.443	4773	1.42	0.933	10053
	870	4.35	0.435	0.248	3600	0.574	0.333	4825	1.10	0.704	10199
250	1750	7.00	0.665	0.396	3563	0.838	0.509	4581	1.610	1.060	9566
	1170	4.68	0.479	0.270	3633	0.603	0.347	4673	1.160	0.729	9822
	870	3.48	0.375	0.203	3669	0.472	0.261	4722	0.903	0.550	9957
300	1750	5.83	0.580	0.332	3589	0.811	0.450	4865	1.500	0.969	10475
	1170	3.90	0.417	0.224	3625	0.589	0.308	4975	1.030	0.634	10244
	870	2.90	0.327	0.168	3643	0.463	0.232	5033	0.797	0.476	10343
400	1750	4.38	0.467	0.250	3599	0.616	0.335	4824	1.150	0.708	10197
	1170	2.92	0.336	0.169	3636	0.444	0.226	4876	0.824	0.480	10340
	870	2.18	0.264	0.126	3655	0.349	0.169	4902	0.640	0.360	10416
500	1750	3.50	0.402	0.204	3669	0.528	0.270	4855	1.010	0.596	10732
	1170	2.34	0.290	0.138	3705	0.382	0.182	4896	0.688	0.386	10399
	870	1.74	0.229	0.103	3723	0.300	0.136	4918	0.534	0.289	10459
600	1750	2.92	0.357	0.170	3671	0.497	0.233	5032	0.890	0.498	10749
	1170	1.95	0.258	0.115	3707	0.361	0.157	5088	0.612	0.320	10438
	870	1.45	0.203	0.086	3725	0.285	0.118	5118	0.477	0.241	10489
750	1750	2.33	0.313	0.137	3705	0.429	0.188	5066	0.770	0.393	10630
	1170	1.56	0.229	0.092	3729	0.313	0.127	5111	0.532	0.257	10365
	870	1.16	0.184	0.069	3742	0.247	0.095	5135	0.415	0.192	10428
900	1750	1.94	0.290	0.119	3865	0.389	0.157	5088	0.657	0.318	10305
	1170	1.30	0.203	0.077	3731	0.286	0.106	5127	0.475	0.215	10406
	870	.967	0.164	0.057	3743	0.228	0.079	5146	0.371	0.16	10458
1000	1750	1.75	0.262	0.103	3723	0.334	0.134	4821	0.607	0.284	10211
	1170	1.17	0.195	0.069	3741	0.244	0.09	4861	0.437	0.192	10324
	870	.870	0.156	0.052	3751	0.192	0.067	4882	0.341	0.143	10383
1200	1750	1.46	0.233	0.086	3725	0.327	0.118	5117	0.541	0.240	10381
	1170	.975	0.174	0.058	3743	0.241	0.079	5146	0.392	0.162	10457
	870	.725	0.139	0.043	3742	0.196	0.059	5161	0.310	0.121	10496
1500	1750	1.17	0.211	0.069	3741	0.287	0.095	5134	0.460	0.193	10427
	1170	.780	0.158	0.046	3754	0.216	0.064	5158	0.333	0.130	10488
	870	.580	0.127	0.035	3760	0.175	0.048	5169	0.267	0.097	10519
1800	1750	.972	0.188	0.058	3743	0.261	0.079	5146	0.42	0.161	10457
	1170	.650	0.142	0.039	3755	0.199	0.053	5165	0.311	0.108	10508
	870	.483	0.114	0.029	3762	0.161	0.04	5175	0.249	0.081	10535
2400	1750	.729	0.158	0.042	3646	0.206	0.057	4892	0.346	0.120	10411
	1170	.488	0.120	0.028	3659	0.156	0.038	4909	0.258	0.081	10459
	870	.363	0.097	0.021	3665	0.126	0.028	4918	0.206	0.060	10484
3000	1750	.583	0.137	0.033	3588	0.170	0.043	4620	0.290	0.094	10162
	1170	.390	0.104	0.019	3600	0.129	0.029	4636	0.211	0.061	9848
	870	.290	0.084	0.017	3606	0.105	0.021	4644	0.169	0.045	9870
3600	1750	.486	0.120	0.026	3406	0.143	0.033	4300	0.235	0.070	9103
	1170	.325	0.091	0.018	3417	0.109	0.022	4314	0.177	0.047	9141
	870	.242	0.074	0.013	3423	0.088	0.017	4321	0.142	0.035	9161



# Horsepower and Torque Ratings/Double Reduction

Worm-Worm

Nominal Ratio	SPEED (rpm)		SIZE 1525			SIZE 1600			SIZE 1700			SIZE 1800			SIZE 11000		
	Input	Approx. Output	Horsepower		Output Torque (lb-in)	Horsepower		Output Torque (lb-in)	Horsepower		Output Torque (lb-in)	Horsepower		Output Torque (lb-in)	Horsepower		Output Torque (lb-in)
			Input	Output		Input	Output		Input	Output		Input	Output				
75	1750	23.3	5.00	3.85	10414	8.89	6.97	19461	9.50	7.86	21261	15.5	13.0	35507	26.5	22.5	61010
	1170	15.6	4.05	3.00	12505	6.82	5.14	21444	7.69	6.16	25161	12.0	9.78	39931	20.4	16.9	68348
	870	11.6	3.47	2.49	13984	5.49	4.02	22548	6.80	5.32	29208	9.57	7.61	41787	16.3	13.2	72067
100	1750	17.5	5.00	3.66	13181	7.81	5.36	19935	9.50	7.51	27047	12.6	10.1	38575	20.8	17.0	64363
	1170	11.7	4.05	2.83	15747	5.54	3.94	21936	7.04	5.37	30607	9.55	7.40	42191	16.2	12.8	72302
	870	8.70	3.47	2.33	17474	4.48	3.08	23048	5.61	4.16	31879	7.64	5.76	44192	13.0	10.0	76335
150	1750	11.7	4.27	2.98	16089	5.69	4.17	22529	7.54	5.75	30974	10.21	7.92	42663	16.5	13.0	72069
	1170	7.80	3.32	2.21	17819	3.11	2.93	23649	5.31	3.90	32270	7.23	5.41	44811	12.3	9.38	77678
	870	5.80	2.63	1.69	18346	3.28	2.23	24250	4.18	2.98	33158	5.71	4.15	46217	9.78	7.25	80749
200	1750	8.75	3.78	2.54	18295	4.64	3.20	23029	5.81	4.32	31857	7.92	5.98	44158	13.5	10.3	76261
	1170	5.85	2.66	1.70	18332	2.55	2.24	24157	4.21	3.00	33136	5.75	4.18	46181	9.93	7.31	80671
	870	4.35	2.09	1.29	18738	2.70	1.71	24762	3.29	2.28	33817	4.50	3.18	47264	7.83	5.59	83051
250	1750	7.00	3.10	1.96	17654	3.96	2.57	23137	5.10	3.68	33133	6.61	4.88	43010	11.3	8.45	74571
	1170	4.68	2.28	1.37	18413	2.18	1.80	24264	3.55	2.46	32432	4.80	3.40	44863	8.31	5.96	78638
	870	3.48	1.81	1.04	18818	2.32	1.37	24869	2.77	1.86	33067	3.76	2.58	45852	6.55	4.55	80828
300	1750	5.83	2.66	1.700	18332	3.54	2.33	25188	4.27	2.99	33136	5.82	4.17	46181	10.1	7.29	80671
	1170	3.90	1.93	1.170	18861	2.45	1.54	24835	3.06	2.05	34024	4.19	2.87	47593	7.29	5.06	83779
	870	2.90	1.51	0.881	19138	1.91	1.16	25148	2.39	1.55	34489	3.26	2.17	48334	5.71	3.84	85419
400	1750	4.38	2.25	1.350	19426	2.80	1.720	24752	3.41	2.29	33805	4.65	3.20	47245	8.12	5.62	83011
	1170	2.92	1.56	0.888	19131	2.02	1.180	25351	2.43	1.56	34477	3.33	2.19	48316	5.85	3.87	85377
	870	2.18	1.22	0.668	19342	1.59	0.886	25666	2.10	1.17	34830	2.59	1.65	48879	4.58	2.92	86628
500	1750	3.50	1.90	1.090	19628	2.36	1.400	25111	2.86	1.850	34209	3.88	2.60	45835	6.89	4.57	84431
	1170	2.34	1.32	0.716	19295	1.71	0.950	25596	2.04	1.260	34752	2.78	1.77	46812	4.96	3.13	86351
	870	1.74	1.03	0.537	19465	1.34	0.714	25851	1.59	0.944	35036	2.16	1.33	47326	3.88	2.35	87361
600	1750	2.92	1.600	0.885	19131	2.10	1.170	25351	2.53	1.56	34477	3.43	2.18	48316	6.27	4.01	86551
	1170	1.95	1.150	0.600	19405	1.52	0.797	25761	1.81	1.06	34936	2.46	1.48	49049	4.34	2.63	87006
	870	1.45	0.897	0.450	19547	1.20	0.598	25975	1.42	0.79	35174	1.92	1.11	49429	3.40	1.97	87854
750	1750	2.33	1.380	0.711	19211	1.89	0.979	26481	2.13	1.270	33682	2.87	1.770	46812	5.04	3.13	82964
	1170	1.56	0.998	0.482	19485	1.32	0.640	25868	1.53	0.862	34109	2.05	1.200	47481	3.63	2.13	84459
	870	1.16	0.782	0.361	19627	1.04	0.480	26081	1.20	0.645	34331	1.60	0.898	47827	2.85	1.60	85236
900	1750	1.94	1.240	0.593	19222	1.540	0.785	25450	1.800	1.050	34111	2.50	1.470	46627	4.13	2.49	79353
	1170	1.30	0.895	0.402	19495	1.120	0.529	25658	1.240	0.679	32391	1.80	0.991	46972	2.97	1.69	80681
	870	.967	0.703	0.301	19637	0.884	0.395	25766	0.972	0.508	32585	1.42	0.740	47150	2.33	1.27	81371
1000	1750	1.75	1.150	0.539	19418	1.520	0.748	26939	1.730	0.949	35031	2.34	1.330	49201	4.21	2.37	87344
	1170	1.17	0.832	0.364	19624	1.060	0.484	26095	1.240	0.640	35308	1.68	0.899	49644	3.05	1.60	88332
	870	.870	0.654	0.272	19729	0.834	0.362	26224	0.976	0.477	35452	1.32	0.672	49874	2.41	1.20	88847
1200	1750	1.46	1.030	0.450	19428	1.330	0.624	26936	1.520	0.794	35168	2.05	1.120	49420	3.73	1.98	87832
	1170	.975	0.748	0.304	19633	0.935	0.405	26179	1.100	0.534	35402	1.48	0.752	49793	2.72	1.34	88666
	870	.725	0.589	0.227	19738	0.739	0.302	26287	0.871	0.399	35522	1.16	0.561	49986	2.15	1.00	89097
1500	1750	1.17	0.900	0.377	20308	1.120	0.483	26076	1.280	0.648	34325	1.710	0.903	47819	3.13	1.610	85216
	1170	.780	0.632	0.245	19763	0.816	0.325	26285	0.929	0.436	34542	1.230	0.608	48159	2.28	1.090	85980
	870	.580	0.505	0.183	19835	0.646	0.243	26393	0.739	0.325	34654	0.979	0.454	48334	1.81	0.811	86375
1800	1750	.972	0.779	0.303	19633	1.000	0.401	26022	1.040	0.511	32580	1.340	0.700	45388	2.56	1.280	81353
	1170	.650	0.570	0.204	19772	0.734	0.271	26232	0.755	0.344	32770	0.928	0.453	43207	1.86	0.860	82031
	870	.483	0.456	0.152	19844	0.583	0.202	26340	0.603	0.256	32868	0.738	0.338	43342	1.48	0.643	82381
2400	1750	.729	0.662	0.225	19401	0.821	0.303	26181	0.899	0.389	33661	1.200	0.544	46987	2.17	0.964	83314
	1170	.488	0.486	0.151	19538	0.625	0.201	25986	0.654	0.262	33868	0.869	0.366	47314	1.59	0.650	84037
	870	.363	0.391	0.113	19608	0.497	0.15	26092	0.525	0.195	33975	0.694	0.273	47482	1.26	0.486	84411
3000	1750	.583	0.579	0.174	18822	0.691	0.235	25350	0.758	0.301	32512	1.020	0.423	45708	1.83	0.78	80836
	1170	.390	0.427	0.117	18955	0.548	0.156	25211	0.554	0.202	32710	0.743	0.285	46025	1.35	0.505	81535
	870	.290	0.345	0.088	19024	0.437	0.117	25314	0.446	0.151	32813	0.595	0.213	46189	1.08	0.377	81896
3600	1750	.486	0.510	0.138	17865	0.653	0.183	23679	0.598	0.226	29307	0.801	0.317	41112	1.520	0.588	76252
	1170	.325	0.377	0.093	17991	0.484	0.123	23869	0.437	0.152	29473	0.583	0.213	41376	1.070	0.381	73877
	870	.242	0.305	0.069	18056	0.386	0.092	23967	0.353	0.113	29558	0.470	0.159	41512	0.856	0.285	74183

# Double Reduction/Worm-Worm/Basic Drive

## Dimensions- Inches

Type  
**WBWM**

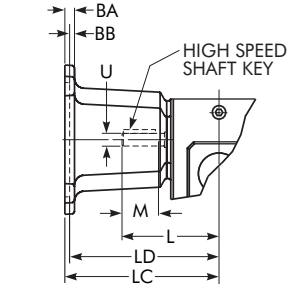
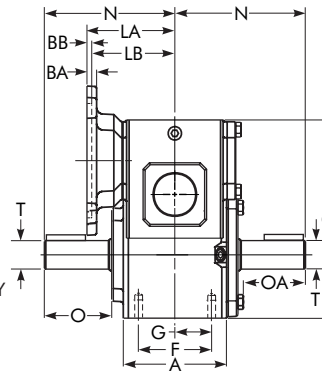
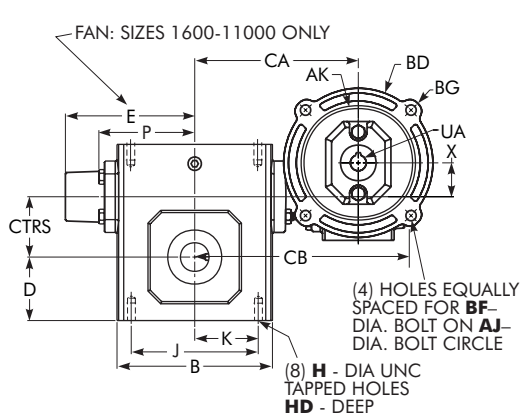

Type  
**WBWF**

Type  
**WBW**

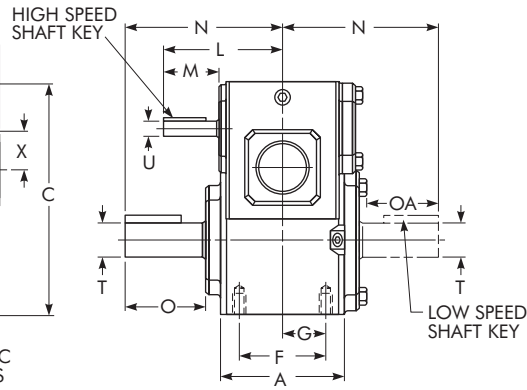
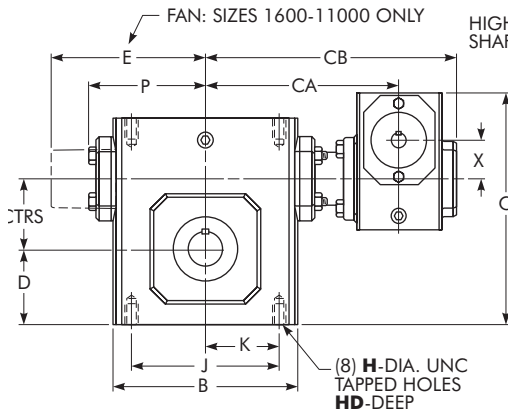

SEE PAGE 61 FOR MOTOR MOUNTING DIMENSIONS.

(Continued on next page)

DRIVE SIZE ★	CTRS	A	B	C	D	E	F	G	H	HD	J	K	L	M •	N	O ♦	OA ♦	P	Low Speed Shaft	
																			T - .0005 - .0015	Key
<b>1133</b>	1.33	2.82	3.80	5.99	1.72	...	2.00	1.00	.3125-18	.50	3.25	1.63	3.82	1.76	4.00	2.16	1.94	2.61	.6250	.188 x .188 x 1.50
<b>1154</b>	1.54	3.44	4.88	6.38	1.91	...	2.75	1.38	.3125-18	.63	4.19	2.09	3.82	1.76	4.31	2.11	1.90	3.14	.7500	.188 x .188 x 1.50
<b>1175</b>	1.75	3.56	5.06	6.75	2.06	...	2.75	1.38	.3125-18	.63	4.19	2.09	3.82	1.76	4.31	2.05	1.84	3.24	.8750	.188 x .188 x 1.38
<b>1206</b>	2.06	3.81	5.80	7.28	2.28	...	3.00	1.50	.3125-18	.63	4.75	2.38	3.82	1.76	4.68	2.29	2.08	3.61	1.0000	.250 x .250 x 1.44
<b>1238</b>	2.38	4.06	6.12	7.81	2.50	...	2.88	1.44	.3750-16	.56	5.00	2.50	3.82	1.76	5.14	2.66	2.44	3.77	1.1250	.250 x .250 x 1.75
<b>1262</b>	2.63	4.84	7.12	8.50	2.94	...	3.38	1.69	.3750-16	.69	6.38	3.19	3.82	1.76	5.63	2.73	2.52	4.34	1.1250	.250 x .250 x 1.44
<b>1300</b>	3.00	5.25	8.12	9.72	3.25	...	4.00	2.00	.4375-14	.88	7.00	3.50	4.35	1.76	6.75	3.60	3.36	4.84	1.2500	.250 x .250 x 2.25
<b>1325</b>	3.25	5.75	8.50	10.22	3.50	...	4.00	2.00	.4375-14	.88	7.50	3.75	4.35	1.76	7.06	3.66	3.42	5.02	1.3750	.313 x .313 x 2.50
<b>1425</b>	4.25	6.13	10.25	12.78	4.44	...	5.00	2.50	.6250-11	1.00	8.50	4.25	4.82	1.76	8.12	4.50	4.21	6.10	1.8750	.500 x .500 x 3.06
<b>1525</b>	5.25	7.19	13.00	15.43	5.12	...	5.81	2.91	.6250-11	1.25	11.00	5.50	6.07	2.38	9.06	4.78	4.53	7.50	2.0000	.500 x .500 x 3.50
<b>1600</b>	6.00	8.13	14.25	18.38	6.50	10.24	6.38	3.19	.6250-11	1.00	12.75	6.38	6.76	2.38	10.00	4.66	4.66	...	2.2500	.500 x .500 x 4.00
<b>1700</b>	7.00	7.63	14.88	20.46	7.59	10.63	5.50	2.75	1.0000-8	1.56	12.50	6.25	6.76	2.38	11.76	5.69	5.69	...	2.7500	.625 x .625 x 4.00
<b>1800</b>	8.00	8.63	17.00	23.79	8.86	11.93	6.50	3.25	1.0000-8	1.66	14.25	7.13	9.57	3.47	12.25	6.02	6.02	...	3.0000	.750 x .750 x 4.50
<b>11000</b>	10.00	9.53	20.88	29.24	10.36	14.34	6.88	3.44	1.2500-7	2.04	17.75	8.88	10.88	3.38	14.75	6.80	6.80	...	3.7500	.875 x .875 x 5.00

(See Page 5 for footnotes.)

Type  
**WBWQM**

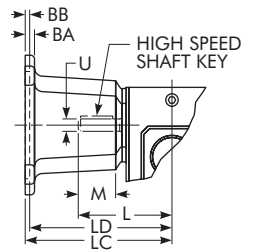
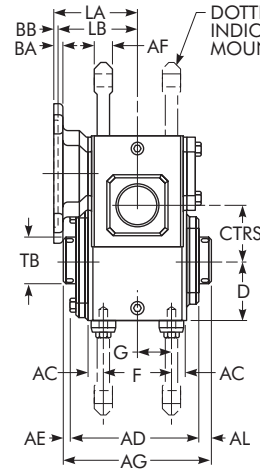
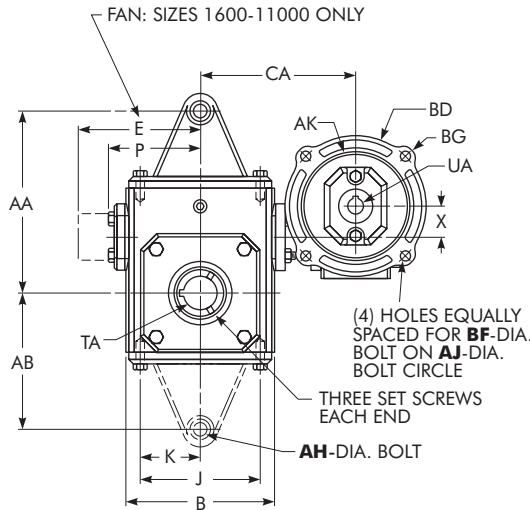

Type  
**WBWQF**

Type  
**WBWQ**

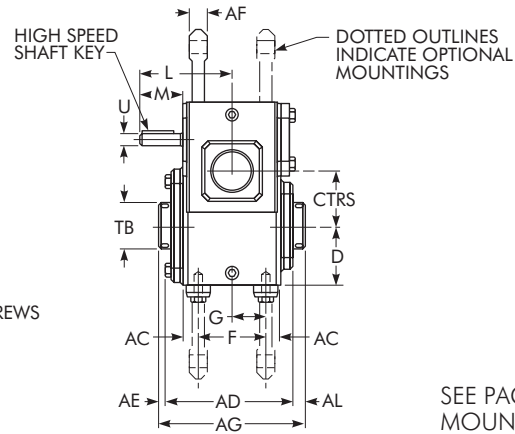
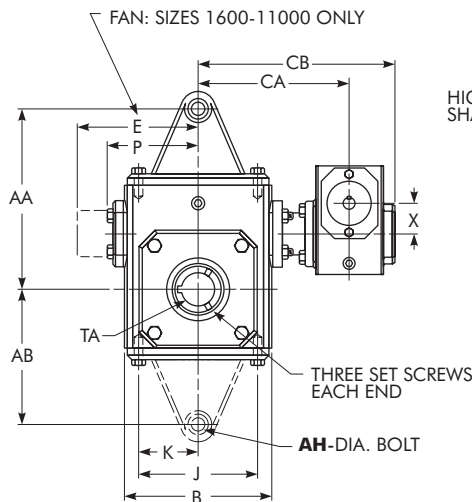

SEE PAGE 61 FOR MOTOR MOUNTING DIMENSIONS.

(Continued from preceding page)

DRIVE SIZE ★	Hollow Low Speed Shaft				High Speed Shaft													Approx. Wt - lb						
	TA	TB	Key	U	Key	X	AA	AB	AC	AD	AE	AF	AG	AH	AL	CA	CB	WBWM	WBWF	WBW	WBWQM	WBWQF	WBWQ	
	Max =																							Key
	+.002 -.000			-.0005 -.0015																				
<b>1133</b>	.625	1.00	.188 x .188 x 1.25	.5000	.125 x .125 x 1.44	1.33	4.19	2.97	.41	3.90	.32	.25	4.75	.53	.53	5.32	7.16	26	30	25	26	30	25	25
<b>1154</b>	.625	1.00	.188 x .188 x 1.25	.5000	.125 x .125 x 1.44	1.33	5.97	4.41	.35	4.61	.30	.75	5.42	.53	.51	5.85	7.69	31	35	30	31	35	30	30
<b>1175</b>	1.000	1.44	.250 x .250 x 2.50	.5000	.125 x .125 x 1.44	1.33	6.19	4.56	.41	4.73	.28	.75	5.50	.53	.49	5.94	7.79	34	38	33	35	39	34	34
<b>1206</b>	1.438	1.94	.375 x .375 x 3.00	.5000	.125 x .125 x 1.44	1.33	7.24	5.43	.41	4.99	.40	.75	6.00	.53	.61	6.32	8.16	39	43	38	42	46	41	41
<b>1238</b>	1.438	1.94	.375 x .375 x 3.00	.5000	.125 x .125 x 1.44	1.33	7.69	5.75	.59	5.18	.31	.75	6.00	.53	.51	6.44	8.29	55	59	52	56	60	53	53
<b>1262</b>	1.438	1.94	.375 x .375 x 3.00	.5000	.125 x .125 x 1.44	1.33	8.81	6.69	.73	6.01	.39	.75	7.00	.53	.60	7.01	8.85	68	72	65	66	70	63	63
<b>1300</b>	1.938	2.51	.500 x .500 x 3.00	.6250	.188 x .188 x 1.50	1.54	10.63	8.25	.63	6.53	.36	.75	7.50	.53	.60	7.86	10.06	93	97	90	93	97	90	90
<b>1325</b>	1.938	2.51	.500 x .500 x 3.00	.6250	.188 x .188 x 1.50	1.54	10.88	8.50	.88	7.04	.29	.75	7.88	.53	.54	8.05	10.25	103	108	101	103	108	101	101
<b>1425</b>	2.188	2.75	.500 x .500 x 3.00	.6250	.188 x .188 x 1.50	2.06	11.94	9.44	.56	7.53	.34	.75	8.50	.53	.63	9.18	11.57	158	162	155	158	162	155	155
<b>1525</b>	3.438	4.26	.875 x .875 x 4.00	.7500	.188 x .188 x 1.75	2.63	13.88	10.12	.69	8.85	.68	1.00	10.50	.66	.97	11.57	14.47	291	292	283	291	292	283	283
<b>1600</b>	3.438	4.18	.875 x .875 x 4.00	.8750	.188 x .188 x 1.75	3.25	15.00	11.50	.88	10.52	.52	.38	11.50	.66	.52	13.30	16.70	393	404	389	393	404	389	389
<b>1700</b>	3.938	4.92	1.000 x 1.000 x 7.00	.8750	.188 x .188 x 1.75	3.25	...	...	1.06	11.36	1.09	...	13.50	...	1.09	12.96	16.90	482	493	478	482	493	478	478
<b>1800</b>	4.438	5.55	1.000 x 1.000 x 7.00	1.2500	.250 x .250 x 2.88	4.25	...	...	1.06	12.48	1.03	...	14.50	...	1.03	13.94	18.19	728	736	718	728	736	718	718
<b>11000</b>	5.438	6.67	1.250 x 1.250 x 12.00	1.2500	.250 x .250 x 3.00	5.25	...	...	1.33	15.78	1.39	...	18.50	...	1.39	17.05	22.30	1151	1158	1136	1151	1158	1136	1136

# Assemblies \*

Reverse all arrows for opposite rotation of high speed shaft.  
 Shaft rotation is viewed by looking at each shaft extension.

## SIZES 1133-1600

## SIZES 1700-11000

**WBWM  
&  
WBWF**

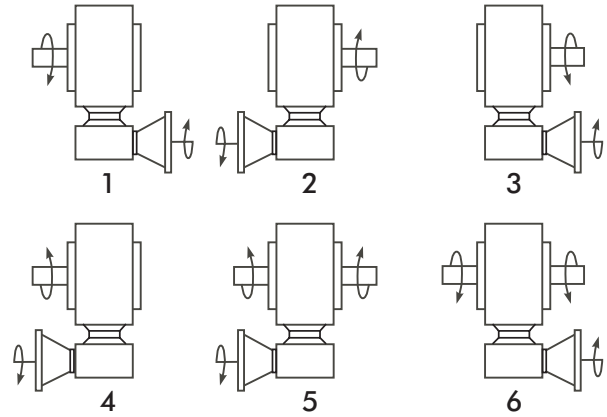
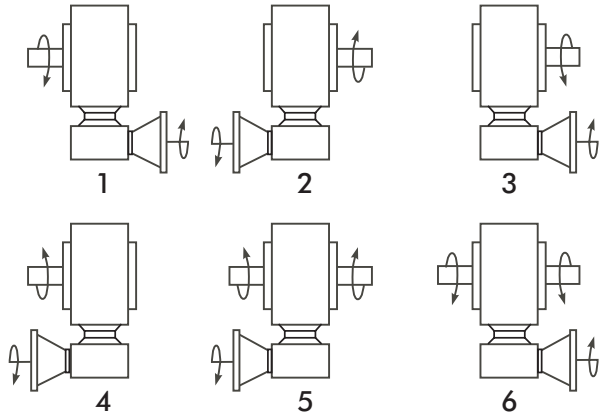

**WBWQM  
&  
WBWQF**

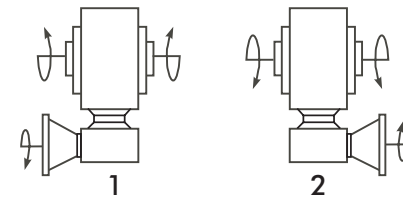
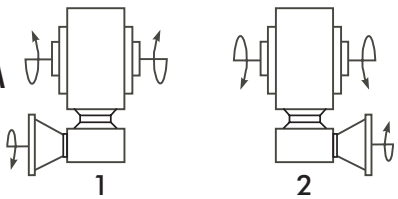

**WBW**

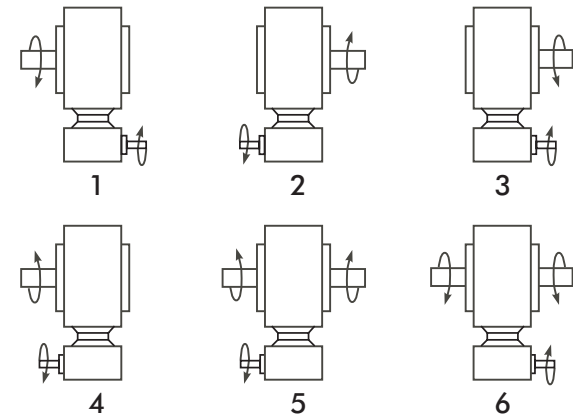
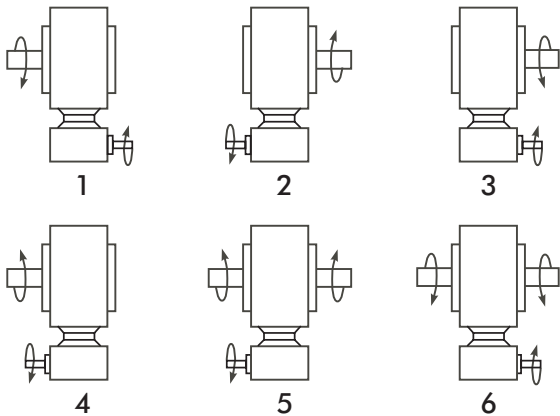

**WBWQ**

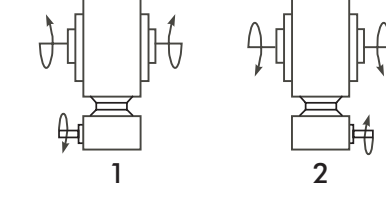
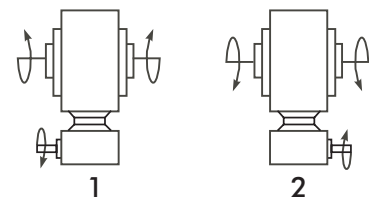

(See Page 5 for footnotes.)

# Motor Data

## NEMA Motor Flange Face Locations — Inches

DRIVE SIZE	56C/140TC		180TC		210TC		250TC	
	LA	LC	LB	LD	LB	LD	LB	LD
1133	3.46	6.07	...	...	...	...	...	...
1154	3.46	6.07	...	...	...	...	...	...
1175	3.46	6.07	...	...	...	...	...	...
1206	3.46	6.07	...	...	...	...	...	...
1238	3.46	6.07	...	...	...	...	...	...
1262	3.46	6.07	...	...	...	...	...	...
1300	3.99	6.60	...	...	...	...	...	...
1325	3.99	6.60	...	...	...	...	...	...
1425	4.46	7.07	...	...	...	...	...	...
1525	5.19	8.32	5.62	9.32	...	9.32	...	...
1600	5.88	9.01	6.31	10.01	6.75	10.01	...	...
1700	5.88	9.01	6.31	10.01	6.75	10.01	...	...
1800	6.45	11.81	7.21	12.90	7.21	12.90	7.77	13.46
11000	7.85	13.21	8.61	14.30	8.61	14.30	9.17	14.86

## NEMA Motor Mounting Dimensions — Inches

FRAME SIZE	AJ	AK	BA	BB	BD	BF	BG	UA	Keyway
56C	5.88	4.50	.38	...	5.88	.41	6.64	.625	.1875 x .0938
140TC	5.88	4.50	.38	...	5.88	.41	6.64	.875	.1875 x .0938
180TC	7.25	8.50	...	.50	9.00	.53	...	1.125	.2500 x .1250
210TC	7.25	8.50	...	.50	9.00	.53	...	1.375	.3125 x .1562
250TC	7.25	8.50	...	.50	9.00	.53	...	1.625	.3750 x .1875

## IEC B5 & B3/B5 Motor Flange Dimensions \* — Inches

DRIVE SIZE	D63D	D71D	D80D	D90D	D100LD/D112MD	D132D
	LA	LA	LA	LA	LA	LA
1133	2.62	2.65	2.89	...	...	...
1154	2.62	2.65	2.89	...	...	...
1175	2.62	2.65	2.89	...	...	...
1206	2.62	2.65	2.89	...	...	...
1238	2.62	2.65	2.89	...	...	...
1262	2.62	2.65	2.89	...	...	...
1300	3.15	3.18	3.42	...	...	...
1325	3.15	3.18	3.42	...	...	...
1425	3.62	3.65	3.89	...	...	...
1525	...	4.28	4.90	4.90	5.30	...
1600	...	4.97	5.59	5.59	5.99	...
1700	...	4.97	5.59	5.59	5.99	...
1800	...	...	...	6.38	6.39	7.17
11000	...	...	...	7.78	7.78	8.57

## IEC B5 & B3/B5 Metric Motor Mounting Dimensions — Millimeters

FRAME SIZE	AJ	AK	BA	BD	BF	BG	UA	Keyway
D63D	115	95	10	117	M8 x 1.25	131	11	4 x 2.0
D71D	130	110	11	132	M8 x 1.25	146	14	5 x 2.5
D80D	165	130	15	165	M10 x 1.50	184	19	6 x 3.0
D90D	165	130	15	165	M10 x 1.50	184	24	8 x 3.5
D100LD/D112MD	215	180	18	216	M12 x 1.75	237	28	8 x 3.5
D132D	265	230	18	267	M12 x 1.75	290	38	10 x 4.0

(See Page 5 for footnotes.)

# Double Reduction/Worm-Worm/Worm Over

## Dimensions- Inches

Type  
**WOWM**

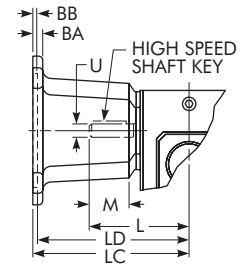
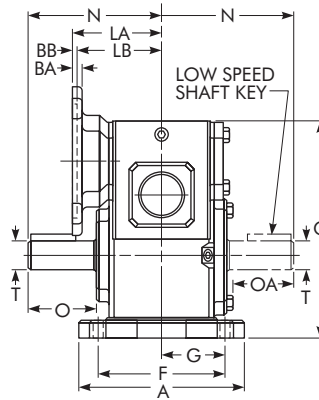
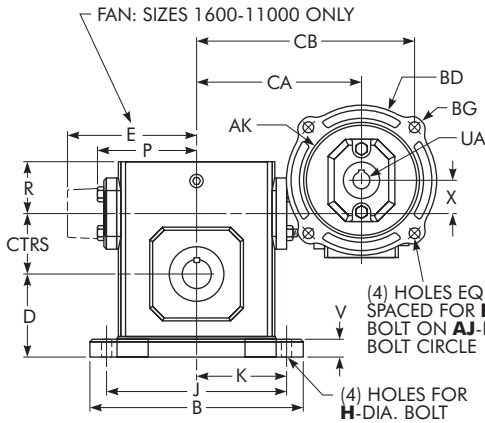

Type  
**WOWF**

Type  
**WOW**

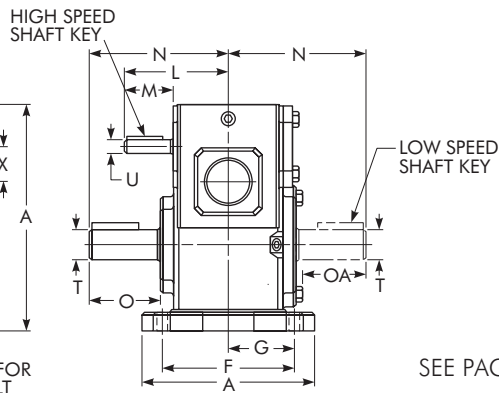
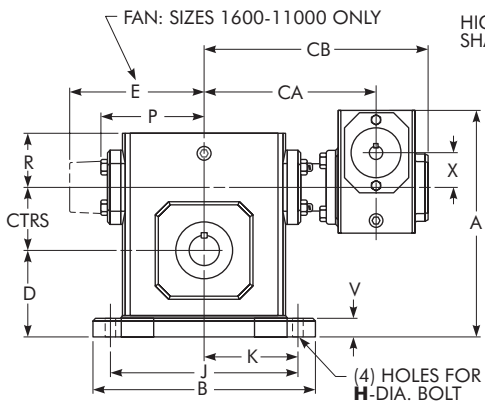

SEE PAGE 65 FOR MOTOR

(Continued on next page)

DRIVE SIZE ★	CTRS	A	B	C	D	E	F	G	H	J	K	L	M •	N	O ♦	OA ♦	P	R	Low Speed Shaft	
																			T	Key
																			-.0005	
1133	1.33	5.38	5.37	6.52	2.25	...	4.38 ▲	2.19 ▲	.34	4.37	2.19	3.82	1.76	4.00	2.16	1.94	2.61	1.61	.6250	.188 x .188 x 1.50
1154	1.54	5.56	6.50	6.98	2.50	...	4.31	2.16	.41	5.25	2.63	3.82	1.76	4.31	2.11	1.90	3.14	1.93	.7500	.188 x .188 x 1.50
1175	1.75	5.75	6.99	7.44	2.75	...	4.50	2.25	.41	5.75	2.88	3.82	1.76	4.31	2.05	1.84	3.24	1.94	.8750	.188 x .188 x 1.38
1206	2.06	6.00	7.69	8.00	3.00	...	4.69	2.34	.47	6.38	3.19	3.82	1.76	4.68	2.29	2.08	3.61	2.03	1.0000	.250 x .250 x 1.44
1238	2.38	6.19	8.37	8.56	3.25	...	4.88	2.44	.47	7.06	3.53	3.82	1.76	5.14	2.66	2.44	3.77	2.06	1.1250	.250 x .250 x 1.75
1262	2.63	6.50	9.25	9.25	3.69	...	5.25	2.63	.53	8.00	4.00	3.82	1.76	5.63	2.73	2.52	4.34	2.44	1.1250	.250 x .250 x 1.44
1300	3.00	7.50	10.00	10.47	4.00	...	5.88	2.94	.53	8.44	4.22	4.35	1.76	6.75	3.60	3.36	4.84	2.63	1.2500	.250 x .250 x 2.25
1325	3.25	7.75	11.12	11.09	4.38	...	6.13	3.06	.53	9.50	4.75	4.35	1.76	7.06	3.66	3.42	5.02	2.63	1.3750	.313 x .313 x 2.50
1425	4.25	9.75	13.24	13.78	5.44	...	7.63	3.81	.66	11.12	5.56	4.82	1.76	8.12	4.50	4.21	6.10	2.69	1.8750	.500 x .500 x 3.06
1525	5.25	10.50	16.24	16.56	6.25	...	8.38	4.19	.78	14.12	7.06	6.07	2.38	9.06	4.78	4.53	7.50	3.63	2.0000	.500 x .500 x 3.50
1600	6.00	12.00	18.99	19.63	7.75	10.24	9.50	4.75	.91	16.49	8.25	6.76	2.38	10.00	4.66	4.66	...	4.00	2.2500	.500 x .500 x 4.00
1700	7.00	13.38	15.38	21.88	9.00	10.63	11.25	5.63	1.13	13.00	6.50	6.76	2.38	11.76	5.69	5.69	...	4.33	2.7500	.625 x .625 x 4.00
1800	8.00	13.50	17.37	25.44	10.50	11.93	11.50	5.75	1.13	14.75	7.38	9.57	3.47	12.25	6.02	6.02	...	4.11	3.0000	.750 x .750 x 4.50
11000	10.00	16.88	21.24	30.88	12.00	14.34	14.00	7.00	1.44	17.00	8.50	10.88	3.38	14.75	6.80	6.80	...	5.12	3.7500	.875 x .875 x 5.00

(See Page 5 for footnotes.)

Type  
**WOWQM**

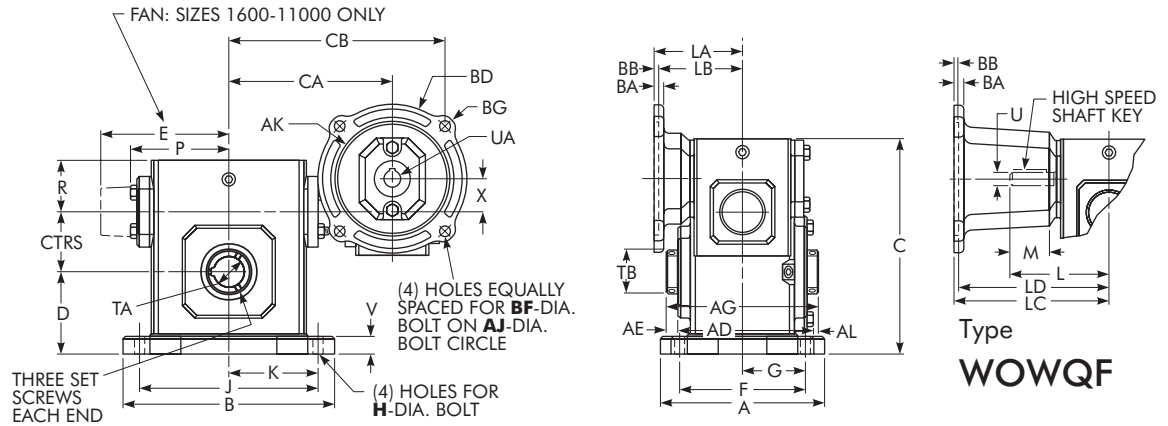

Type  
**WOWQ**

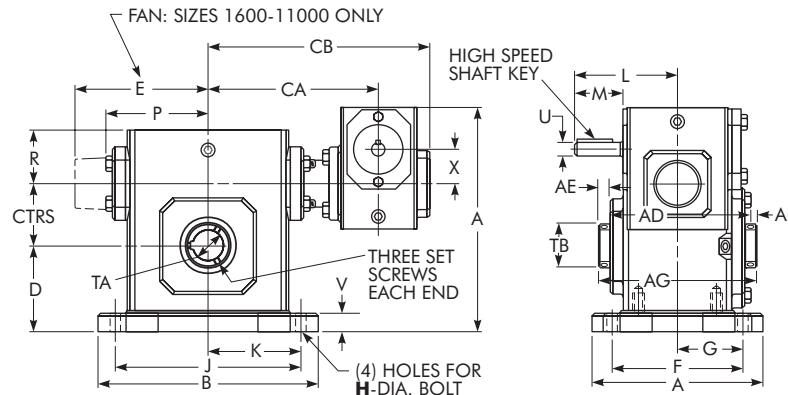

SEE PAGE 65 FOR MOTOR MOUNTING DIMENSIONS.

(Continued from preceding page)

DRIVE SIZE ★	Hollow Low Speed Shaft			High Speed Shaft				Approx. Wt. – lb											
	TA Max = +.002 -.000	TB	Key	U -.0005 -.0015	Key	V	X	AD	AE	AG	AL	CA	CB	WOWM	WOWF	WOW	WOWQM	WOWQF	WOWQ
1133	.625	1.00	.188 x .188 x 1.25	.500	.125 x .125 x 1.44	.53	1.33	3.90	.53	4.75	.32	5.32	7.16	29	33	28	29	33	28
1154	.625	1.00	.188 x .188 x 1.25	.500	.125 x .125 x 1.44	.59	1.33	4.61	.51	5.42	.30	5.85	7.69	34	38	33	34	38	33
1175	1.000	1.44	.250 x .250 x 2.50	.500	.125 x .125 x 1.44	.69	1.33	4.73	.49	5.50	.28	5.94	7.79	37	41	36	38	42	37
1206	1.438	1.94	.375 x .375 x 3.00	.500	.125 x .125 x 1.44	.72	1.33	4.99	.61	6.00	.40	6.32	8.16	42	46	41	45	49	44
1238	1.438	1.94	.375 x .375 x 3.00	.500	.125 x .125 x 1.44	.75	1.33	5.18	.51	6.00	.31	6.44	8.29	63	67	60	64	68	61
1262	1.438	1.94	.375 x .375 x 3.00	.500	.125 x .125 x 1.44	.75	1.33	6.01	.60	7.00	.39	7.01	8.85	78	82	75	76	80	73
1300	1.938	2.51	.500 x .500 x 3.00	.625	.188 x .188 x 1.50	.75	1.54	6.53	.60	7.50	.36	7.86	10.06	109	113	106	109	113	106
1325	1.938	2.51	.500 x .500 x 3.00	.625	.188 x .188 x 1.50	.88	1.54	7.04	.54	7.88	.29	8.05	10.25	119	124	117	119	124	117
1425	2.188	2.75	.500 x .500 x 3.00	.625	.188 x .188 x 1.50	1.00	2.06	7.53	.63	8.50	.34	9.18	11.57	176	180	173	176	180	173
1525	3.438	4.26	.875 x .875 x 4.00	.750	.188 x .188 x 1.75	1.13	2.63	8.85	.97	10.50	.68	11.57	14.47	313	314	305	313	314	305
1600	3.438	4.18	.875 x .875 x 4.00	.875	.188 x .188 x 1.75	1.25	3.25	10.52	.52	11.50	.52	13.30	16.70	424	435	420	424	435	420
1700	3.938	4.92	1.000 x 1.000 x 7.00	.875	.188 x .188 x 1.75	1.42	3.25	11.36	1.09	13.50	1.09	12.96	19.90	523	534	519	523	534	519
1800	4.438	5.55	1.000 x 1.000 x 7.00	1.250	.250 x .250 x 2.88	1.65	4.25	12.48	1.03	14.50	1.03	13.94	18.19	776	784	766	776	784	766
11000	5.438	6.67	1.250 x 1.250 x 12.00	1.250	.250 x .250 x 3.00	1.65	5.25	15.78	1.39	18.50	1.39	17.05	22.30	1227	1234	1212	1227	1234	1212

# Assemblies \*

Reverse all arrows for opposite rotation of high speed shaft.  
 Shaft rotation is viewed by looking at each shaft extension.

SIZES 1133-1600

SIZES 1700-11000

WOWM  
&  
WOWF

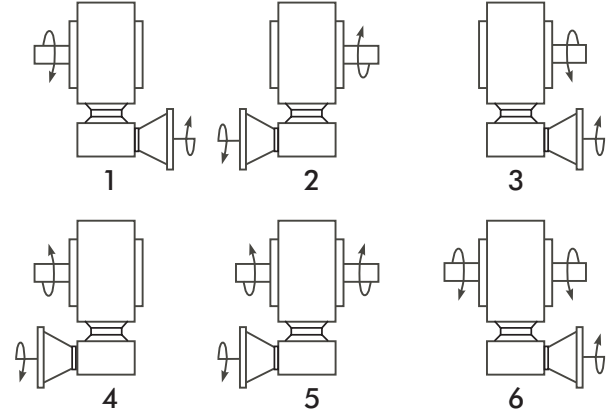
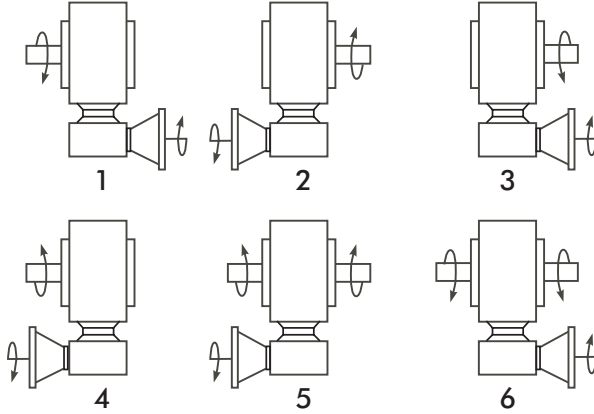

WOWQ  
M  
&  
WOWQF

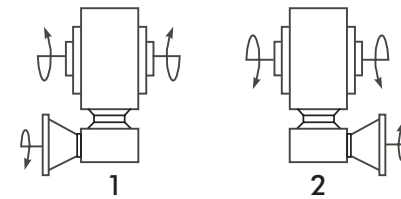
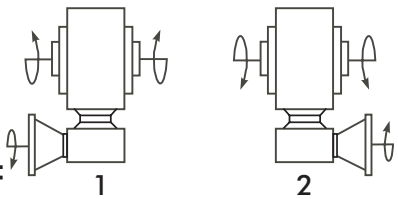

WOW

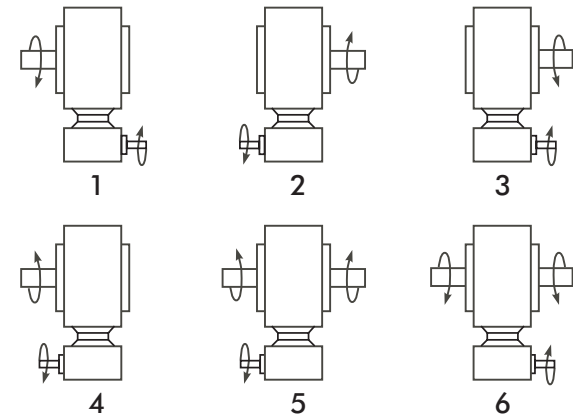
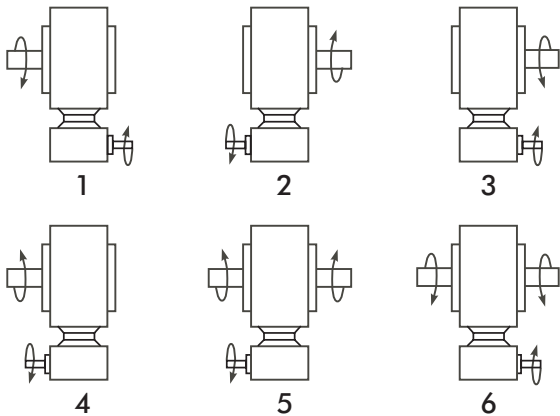

WOWQ

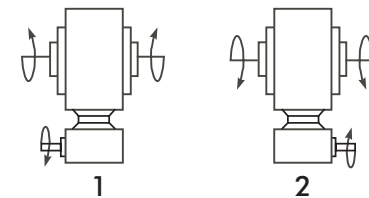
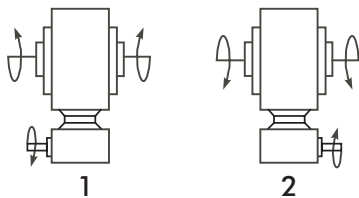

(See Page 5 for footnotes.)



# Motor Data

## NEMA Motor Flange Face Locations — Inches

DRIVE SIZE	56C/140TC		180TC		210TC		250TC	
	LA	LC	LB	LD	LB	LD	LB	LD
1133	3.46	6.07	...	...	...	...	...	...
1154	3.46	6.07	...	...	...	...	...	...
1175	3.46	6.07	...	...	...	...	...	...
1206	3.46	6.07	...	...	...	...	...	...
1238	3.46	6.07	...	...	...	...	...	...
1262	3.46	6.07	...	...	...	...	...	...
1300	3.99	6.60	...	...	...	...	...	...
1325	3.99	6.60	...	...	...	...	...	...
1425	4.46	7.07	...	...	...	...	...	...
1525	5.19	8.32	5.62	9.32	...	9.32	...	...
1600	5.88	9.01	6.31	10.01	6.75	10.01	...	...
1700	5.88	9.01	6.31	10.01	6.75	10.01	...	...
1800	6.45	11.81	7.21	12.90	7.21	12.90	7.77	13.46
11000	7.85	13.21	8.61	14.30	8.61	14.30	9.17	14.86

## NEMA Motor Mounting Dimensions — Inches

FRAME SIZE	AJ	AK	BA	BB	BD	BF	BG	UA	Keyway
56C	5.88	4.50	.38	...	5.88	.41	6.64	.625	.1875 x .0938
140TC	5.88	4.50	.38	...	5.88	.41	6.64	.875	.1875 x .0938
180TC	7.25	8.50	...	.50	9.00	.53	...	1.125	.2500 x .1250
210TC	7.25	8.50	...	.50	9.00	.53	...	1.375	.3125 x .1562
250TC	7.25	8.50	...	.50	9.00	.53	...	1.625	.3750 x .1875

## IEC B5 & B3/B5 Motor Flange Dimensions \* — Inches

DRIVE SIZE	D63D	D71D	D80D	D90D	D100LD/D112MD	D132D
	LA	LA	LA	LA	LA	LA
1133	2.62	2.65	2.89	...	...	...
1154	2.62	2.65	2.89	...	...	...
1175	2.62	2.65	2.89	...	...	...
1206	2.62	2.65	2.89	...	...	...
1238	2.62	2.65	2.89	...	...	...
1262	2.62	2.65	2.89	...	...	...
1300	3.15	3.18	3.42	...	...	...
1325	3.15	3.18	3.42	...	...	...
1425	3.62	3.65	3.89	...	...	...
1525	...	4.28	4.90	4.90	5.30	...
1600	...	4.97	5.59	5.59	5.99	...
1700	...	4.97	5.59	5.59	5.99	...
1800	...	...	...	6.38	6.39	7.17
11000	...	...	...	7.78	7.78	8.57

## IEC B5 & B3/B5 Metric Motor Mounting Dimensions — Millimeters

FRAME SIZE	AJ	AK	BA	BD	BF	BG	UA	Keyway
D63D	115	95	10	117	M8 x 1.25	131	11	4 x 2.0
D71D	130	110	11	132	M8 x 1.25	146	14	5 x 2.5
D80D	165	130	15	165	M10 x 1.50	184	19	6 x 3.0
D90D	165	130	15	165	M10 x 1.50	184	24	8 x 3.5
D100LD/D112MD	215	180	18	216	M12 x 1.75	237	28	8 x 3.5
D132D	265	230	18	267	M12 x 1.75	290	38	10 x 4.0

(See Page 5 for footnotes.)

# Double Reduction/Worm-Worm/Worm Under

## Dimensions — Inches

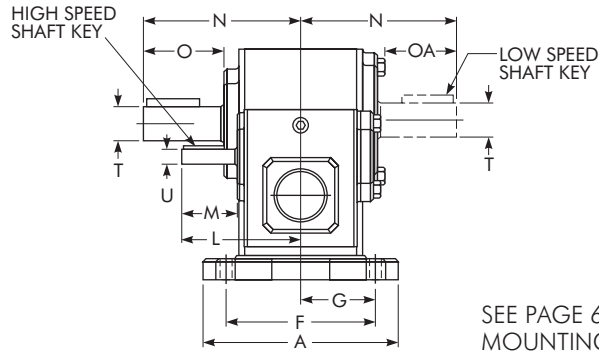
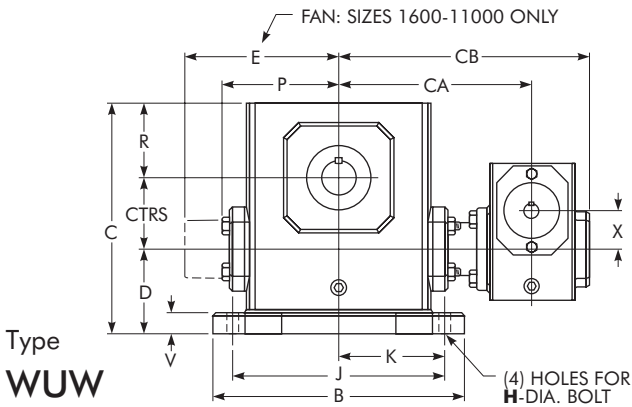
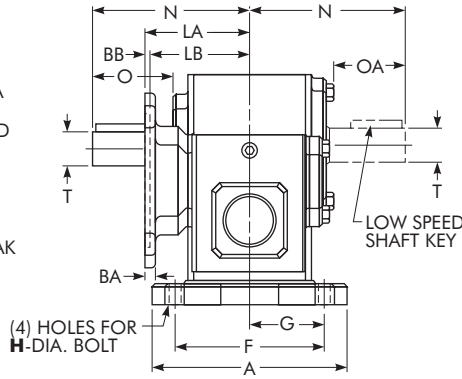
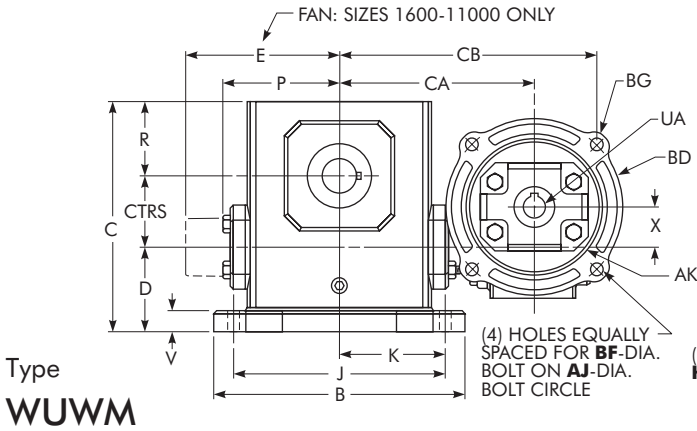

SEE PAGE 69 FOR MOTOR MOUNTING DIMENSIONS.

(Continued on next page)

DRIVE SIZE ★	CTRS	A	B	C	D	E	F	G	H	J	K	L	M •	N	O •	OA •	P	R	Low Speed Shaft	
																			T - .0005 - .0015	Key
<b>1133</b>	1.33	5.38	5.37	5.19	2.14	...	4.38 ▲	2.19 ▲	.34	4.37	2.19	3.82	1.76	4.00	2.16	1.94	2.61	1.72	.6250	.188 x .188 x 1.50
<b>1154</b>	1.54	5.56	6.50	5.97	2.52	...	4.31	2.16	.41	5.25	2.63	3.82	1.76	4.31	2.11	1.90	3.14	1.91	.7500	.188 x .188 x 1.50
<b>1175</b>	1.75	5.75	6.99	6.44	2.63	...	4.50	2.25	.41	5.75	2.88	3.82	1.76	4.31	2.05	1.84	3.24	2.06	.8750	.188 x .188 x 1.38
<b>1206</b>	2.06	6.00	7.69	7.09	2.75	...	4.69	2.34	.47	6.38	3.19	3.82	1.76	4.68	2.29	2.08	3.61	2.28	1.0000	.250 x .250 x 1.44
<b>1238</b>	2.38	6.19	8.37	7.69	2.81	...	4.88	2.44	.47	7.06	3.53	3.82	1.76	5.14	2.66	2.44	3.77	2.50	1.1250	.250 x .250 x 1.75
<b>1262</b>	2.63	6.50	9.25	8.75	3.19	...	5.25	2.63	.53	8.00	4.00	3.82	1.76	5.63	2.73	2.52	4.34	2.94	1.1250	.250 x .250 x 1.44
<b>1300</b>	3.00	7.50	10.00	9.63	3.38	...	5.88	2.94	.53	8.44	4.22	4.35	1.76	6.75	3.60	3.36	4.84	3.25	1.2500	.250 x .250 x 2.25
<b>1325</b>	3.25	7.75	11.12	10.25	3.50	...	6.13	3.06	.53	9.50	4.75	4.35	1.76	7.06	3.66	3.42	5.02	3.50	1.3750	.313 x .313 x 2.50
<b>1425</b>	4.25	9.75	13.24	12.38	3.69	...	7.63	3.81	.66	11.12	5.56	4.82	1.76	8.12	4.50	4.21	6.10	4.44	1.8750	.500 x .500 x 3.06
<b>1525</b>	5.25	10.50	16.24	15.13	4.76	...	8.38	4.19	.78	14.12	7.06	6.07	2.38	9.06	4.78	4.53	7.50	5.12	2.0000	.500 x .500 x 3.50
<b>1600</b>	6.00	12.00	18.99	17.75	5.25	10.24	9.50	4.75	.91	16.49	8.25	6.76	2.38	10.00	4.66	4.66	...	6.50	2.2500	.500 x .500 x 4.00
<b>1700</b>	7.00	13.38	15.38	20.33	5.74	10.63	11.25	5.63	1.13	13.00	6.50	6.76	2.38	11.76	5.69	5.69	...	7.59	2.7500	.625 x .625 x 4.00
<b>1800</b>	8.00	13.50	17.37	22.61	5.75	11.93	11.50	5.75	1.13	14.75	7.38	9.57	3.47	12.25	6.02	6.02	...	8.86	3.0000	.750 x .750 x 4.50
<b>11000</b>	10.00	16.88	21.24	27.12	6.76	14.34	14.00	7.00	1.44	17.00	8.50	10.88	3.38	14.75	6.80	6.80	...	10.36	3.7500	.875 x .875 x 5.00

(See Page 5 for footnotes.)

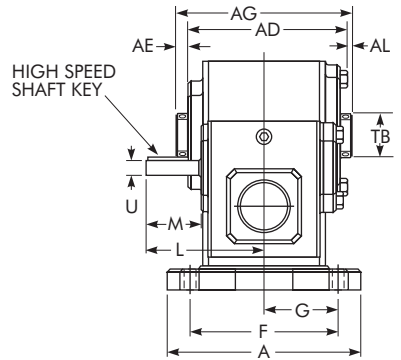
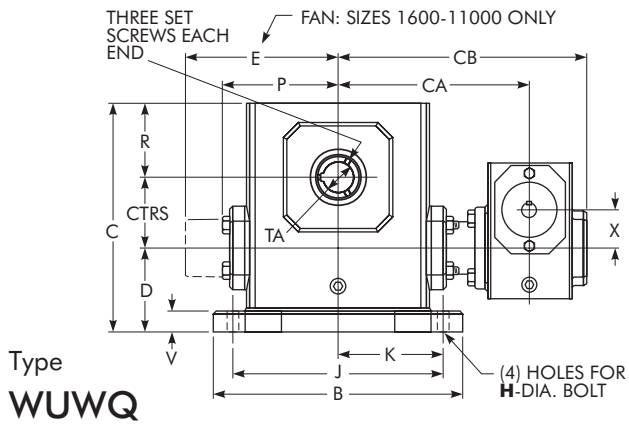
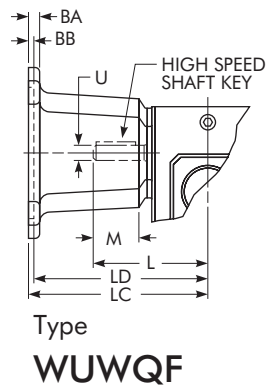
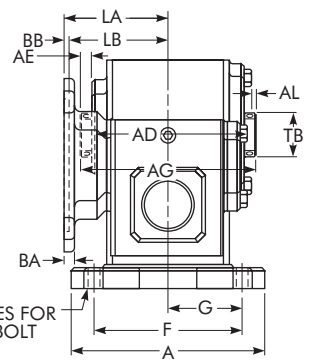
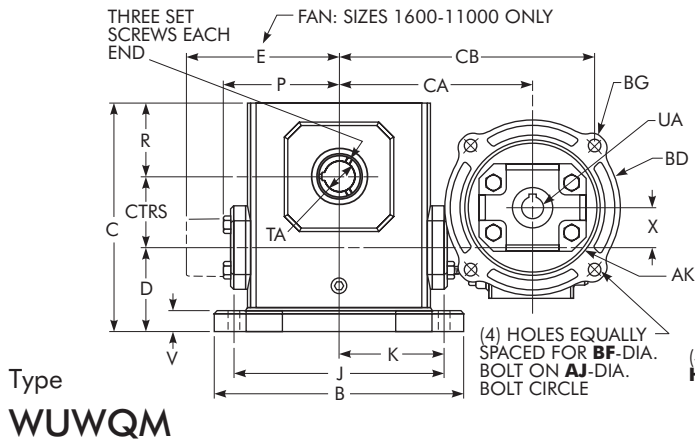

SEE PAGE 69 FOR MOTOR MOUNTING DIMENSIONS.

(Continued from preceding page)

DRIVE SIZE ★	Hollow Low Speed Shaft			High Speed Shaft			Approx. Wt – lb												
	TA Max = +.002 -.000	TB	Key	U -.0005 -.0015	Key	V	X	AD	AE	AG	AL	CA	CB	WUWM	WUWF	WUW	WUWQM	WUWQF	WUWQ
<b>1133</b>	.625	1.00	.188 x .188 x 1.25	.5000	.125 x .125 x 1.44	.53	1.33	3.90	.53	4.75	.32	5.32	7.16	29	33	28	29	33	28
<b>1154</b>	.625	1.00	.188 x .188 x 1.25	.5000	.125 x .125 x 1.44	.59	1.33	4.61	.51	5.42	.30	5.85	7.69	34	38	33	34	38	33
<b>1175</b>	1.000	1.44	.250 x .250 x 2.50	.5000	.125 x .125 x 1.44	.69	1.33	4.73	.49	5.50	.28	5.94	7.79	37	41	36	38	42	37
<b>1206</b>	1.438	1.94	.375 x .375 x 3.00	.5000	.125 x .125 x 1.44	.72	1.33	4.99	.61	6.00	.40	6.32	8.16	42	46	41	45	49	44
<b>1238</b>	1.438	1.94	.375 x .375 x 3.00	.5000	.125 x .125 x 1.44	.75	1.33	5.18	.51	6.00	.31	6.44	8.29	63	67	60	64	68	61
<b>1262</b>	1.438	1.94	.375 x .375 x 3.00	.5000	.125 x .125 x 1.44	.75	1.33	6.01	.60	7.00	.39	7.01	8.85	78	82	75	76	80	73
<b>1300</b>	1.938	2.51	.500 x .500 x 3.00	.6250	.188 x .188 x 1.50	.75	1.54	6.53	.60	7.50	.36	7.86	10.06	109	113	106	109	113	106
<b>1325</b>	1.938	2.51	.500 x .500 x 3.00	.6250	.188 x .188 x 1.50	.88	1.54	7.04	.54	7.88	.29	8.05	10.25	119	124	117	119	124	117
<b>1425</b>	2.188	2.75	.500 x .500 x 3.00	.6250	.188 x .188 x 1.50	1.00	2.06	7.53	.63	8.50	.34	9.18	11.57	176	180	173	176	180	173
<b>1525</b>	3.438	4.26	.875 x .875 x 4.00	.7500	.188 x .188 x 1.75	1.13	2.63	8.85	.97	10.50	.68	11.57	14.47	313	314	305	313	314	305
<b>1600</b>	3.438	4.18	.875 x .875 x 4.00	.8750	.188 x .188 x 1.75	1.25	3.25	10.52	.52	11.50	.52	13.30	16.70	424	435	420	424	435	420
<b>1700</b>	3.938	4.92	1.000 x 1.000 x 7.00	.8750	.188 x .188 x 1.75	1.42	3.25	11.36	1.09	13.50	1.09	12.96	19.90	523	534	519	523	534	519
<b>1800</b>	4.438	5.55	1.000 x 1.000 x 7.00	1.2500	.250 x .250 x 2.88	1.65	4.25	12.48	1.03	14.50	1.03	13.94	18.19	776	784	766	776	784	766
<b>11000</b>	5.438	6.67	1.250 x 1.250 x 12.00	1.2500	.250 x .250 x 3.00	1.65	5.25	15.78	1.39	18.50	1.39	17.05	22.30	1227	1234	1212	1227	1234	1212

# Assemblies\*

Reverse all arrows for opposite rotation of high speed shaft.  
 Shaft rotation is viewed by looking at each shaft extension.

## SIZES 1133-1600

## SIZES 1700-11000

**WUWM  
&  
WUWF**

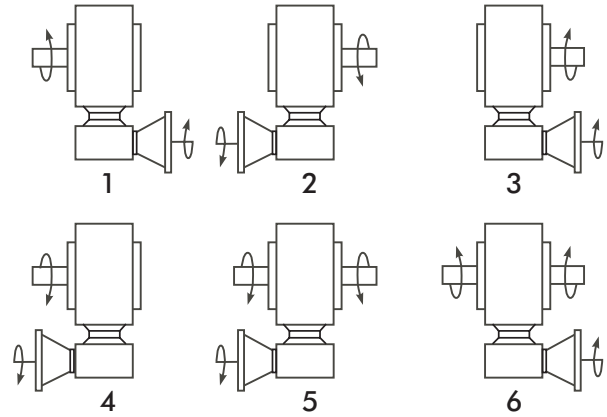
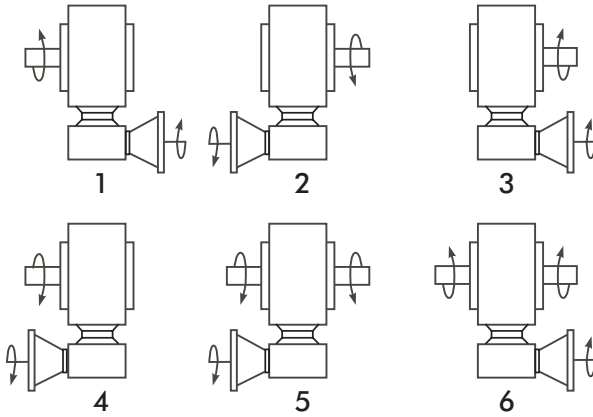

**WUWQ  
M  
&  
WUWQF**

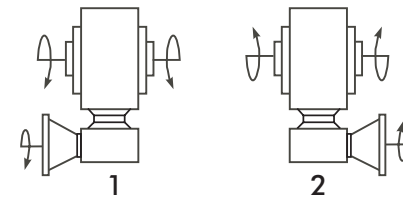
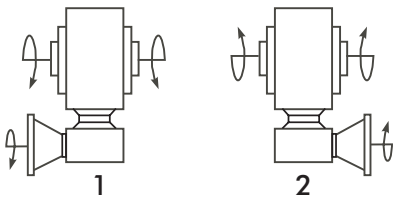

**WUW**

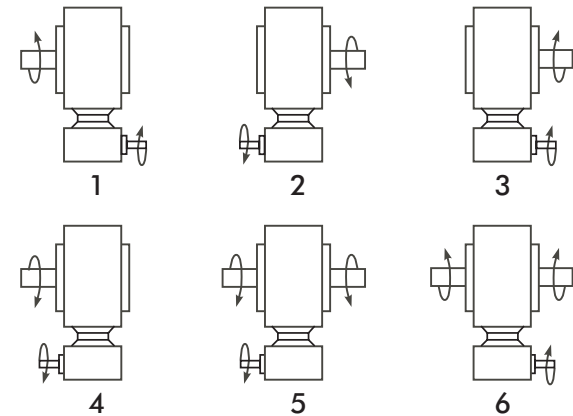
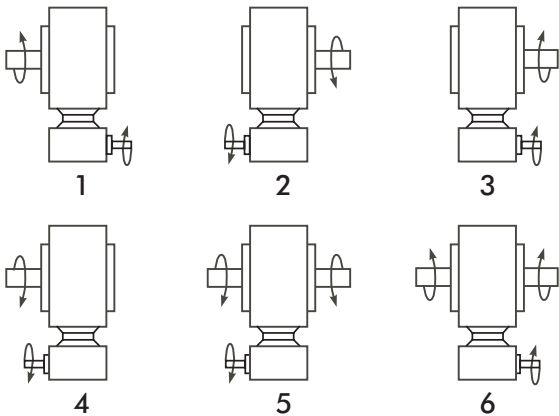

**WUWQ**

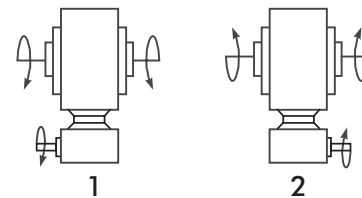
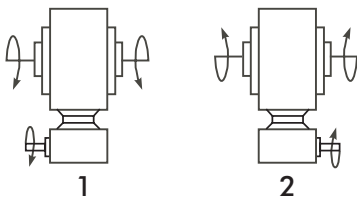

(See Page 5 for footnotes.)

# Motor Data

## NEMA Motor Flange Face Locations — Inches

DRIVE SIZE	56C/140TC		180TC		210TC		250TC	
	LA	LC	LB	LD	LB	LD	LB	LD
1133	3.46	6.07	...	...	...	...	...	...
1154	3.46	6.07	...	...	...	...	...	...
1175	3.46	6.07	...	...	...	...	...	...
1206	3.46	6.07	...	...	...	...	...	...
1238	3.46	6.07	...	...	...	...	...	...
1262	3.46	6.07	...	...	...	...	...	...
1300	3.99	6.60	...	...	...	...	...	...
1325	3.99	6.60	...	...	...	...	...	...
1425	4.46	7.07	...	...	...	...	...	...
1525	5.19	8.32	5.62	9.32	...	9.32	...	...
1600	5.88	9.01	6.31	10.01	6.75	10.01	...	...
1700	5.88	9.01	6.31	10.01	6.75	10.01	...	...
1800	6.45	11.81	7.21	12.90	7.21	12.90	7.77	13.46
11000	7.85	13.21	8.61	14.30	8.61	14.30	9.17	14.86

## NEMA Motor Mounting Dimensions — Inches

FRAME SIZE	AJ	AK	BA	BB	BD	BF	BG	UA	Keyway
56C	5.88	4.50	.38	...	5.88	.41	6.64	.625	.1875 x .0938
140TC	5.88	4.50	.38	...	5.88	.41	6.64	.875	.1875 x .0938
180TC	7.25	8.50	...	.50	9.00	.53	...	1.125	.2500 x .1250
210TC	7.25	8.50	...	.50	9.00	.53	...	1.375	.3125 x .1562
250TC	7.25	8.50	...	.50	9.00	.53	...	1.625	.3750 x .1875

## IEC B5 & B3/B5 Motor Flange Dimensions \* — Inches

DRIVE SIZE	D63D	D71D	D80D	D90D	D100LD/D112MD	D132D
	LA	LA	LA	LA	LA	LA
1133	2.62	2.65	2.89	...	...	...
1154	2.62	2.65	2.89	...	...	...
1175	2.62	2.65	2.89	...	...	...
1206	2.62	2.65	2.89	...	...	...
1238	2.62	2.65	2.89	...	...	...
1262	2.62	2.65	2.89	...	...	...
1300	3.15	3.18	3.42	...	...	...
1325	3.15	3.18	3.42	...	...	...
1425	3.62	3.65	3.89	...	...	...
1525	...	4.28	4.90	4.90	5.30	...
1600	...	4.97	5.59	5.59	5.99	...
1700	...	4.97	5.59	5.59	5.99	...
1800	...	...	...	6.38	6.39	7.17
11000	...	...	...	7.78	7.78	8.57

## IEC B5 & B3/B5 Metric Motor Mounting Dimensions — Millimeters

FRAME SIZE	AJ	AK	BA	BD	BF	BG	UA	Keyway
D63D	115	95	10	117	M8 x 1.25	131	11	4 x 2.0
D71D	130	110	11	132	M8 x 1.25	146	14	5 x 2.5
D80D	165	130	15	165	M10 x 1.50	184	19	6 x 3.0
D90D	165	130	15	165	M10 x 1.50	184	24	8 x 3.5
D100LD/D112MD	215	180	18	216	M12 x 1.75	237	28	8 x 3.5
D132D	265	230	18	267	M12 x 1.75	290	38	10 x 4.0

(See Page 5 for footnotes.)

# Double Reduction/Worm-Worm/Vertical Output

## Dimensions — Inches

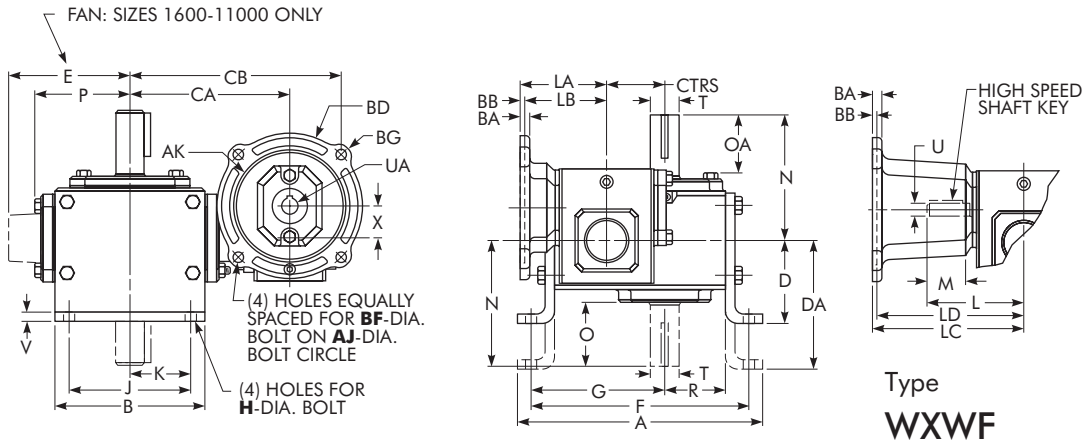

Type  
**WXWM**

Type  
**WXWF**

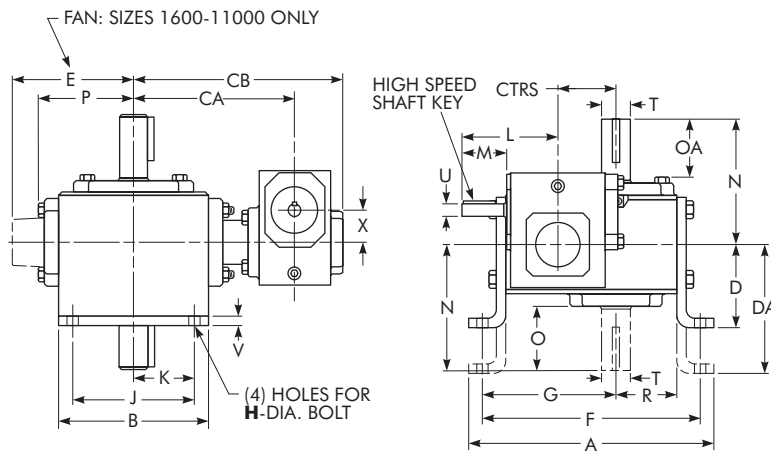

Type  
**WXW**

SEE PAGE 73 FOR MOTOR MOUNTING DIMENSIONS.

(Continued on next page)

DRIVE SIZE ★	CTRS	A	B	D	E	F	G	H	J	K	L	M •	N	O ♦	OA ♦	P	R	Low Speed Shaft	
																		T	Key
																		-.0005 -.0015	
<b>1133</b>	1.33	7.26	4.00	2.63	...	6.50	3.86	.38	3.00	1.50	3.82	1.76	4.00	2.16	1.94	2.61	1.72	.6250	.188 x .188 x 1.50
<b>1154</b>	1.54	7.88	5.00	3.00	...	7.00	4.28	.44	4.00	2.00	3.82	1.76	4.31	2.11	1.90	3.14	1.91	.7500	.188 x .188 x 1.50
<b>1175</b>	1.75	8.25	5.00	3.00	...	7.37	4.50	.44	4.00	2.00	3.82	1.76	4.31	2.05	1.84	3.24	2.06	.8750	.188 x .188 x 1.38
<b>1206</b>	2.06	9.38	6.00	3.13	...	8.38	5.09	.50	4.88	2.44	3.82	1.76	4.68	2.29	2.08	3.61	2.28	1.0000	.250 x .250 x 1.44
<b>1238</b>	2.38	9.94	6.00	3.38	...	8.81	5.38	.50	4.88	2.44	3.82	1.76	5.14	2.66	2.44	3.77	2.50	1.1250	.250 x .250 x 1.75
<b>1262</b>	2.63	11.24	7.00	3.63	...	10.12	6.12	.56	5.75	2.88	3.82	1.76	5.63	2.73	2.52	4.34	2.94	1.1250	.250 x .250 x 1.44
<b>1300</b>	3.00	12.50	8.00	3.94	...	11.13	6.75	.56	6.00	3.00	4.35	1.76	6.75	3.60	3.36	4.84	3.25	1.2500	.250 x .250 x 2.25
<b>1325</b>	3.25	13.00	8.50	4.69	...	11.88	7.13	.56	6.13	3.06	4.35	1.76	7.06	3.66	3.42	5.02	3.50	1.3750	.313 x .313 x 2.50
<b>1425</b>	4.25	16.26	10.00	5.00	...	14.88	8.69	.69	7.88	3.94	4.82	1.76	8.12	4.50	4.21	6.10	4.44	1.8750	.500 x .500 x 3.06
<b>1525</b>	5.25	19.62	13.00	5.16	...	18.00	10.88	.78	10.00	5.00	6.07	2.38	9.06	4.78	4.53	7.50	5.12	2.0000	.500 x .500 x 3.50
<b>1600</b>	6.00	23.26	14.75	7.31	10.24	20.88	12.19	.91	11.76	5.88	6.76	2.38	10.00	4.66	4.66	...	6.50	2.2500	.500 x .500 x 4.00
<b>1700</b>	7.00	26.91	14.88	7.00	10.63	23.99	13.87	1.13	12.50	6.25	6.76	2.38	11.76	5.69	5.69	...	7.59	2.7500	.625 x .625 x 4.00
<b>1800</b>	8.00	28.96	17.00	8.00	11.93	25.50	14.38	1.13	14.00	7.00	9.57	3.47	12.25	6.02	6.02	...	8.86	3.0000	.750 x .750 x 4.50
<b>11000</b>	10.00	37.47	20.88	9.00	14.34	30.75	17.76	1.44	17.75	8.88	10.88	3.38	14.75	6.80	6.80	...	10.36	3.7500	.875 x .875 x 5.00

(See Page 5 for footnotes.)

Type  
**WXWQM**

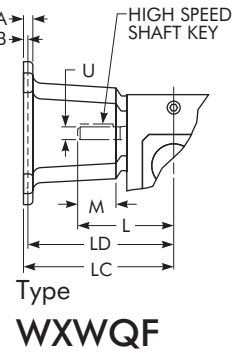
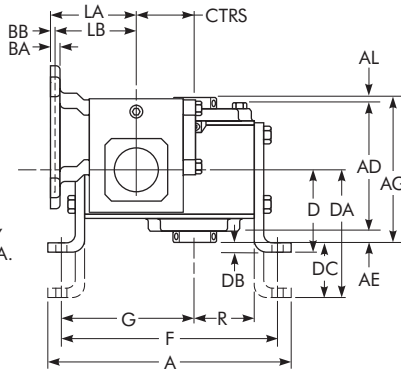
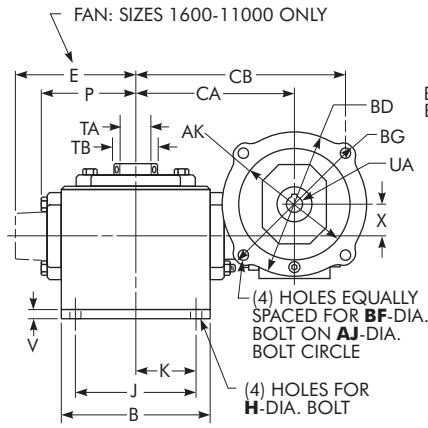

Type  
**WXWQ**

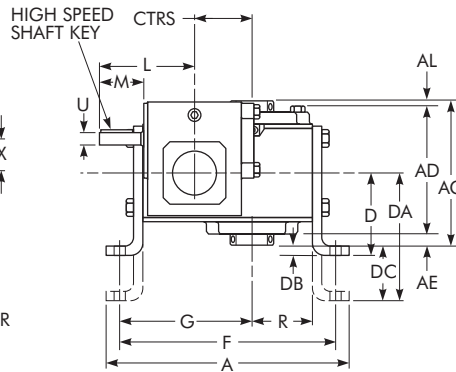
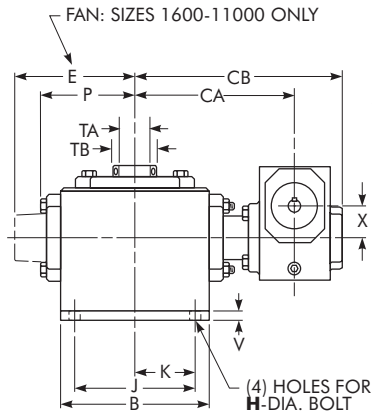

SEE PAGE 73 FOR MOTOR MOUNTING DIMENSIONS.

(Continued from preceding page)

DRIVE SIZE ★	Hollow Low Speed Shaft			High Speed Shaft			Approx. Wt - lb															
	TA Max + .002 - .000	TB	Key	U -.0005 -.0015	Key	V	X	AD	AE	AG	AL	CA	CB	DA	DB	DC	WXWM	WXWF	WXW	WXWQM	WXWQF	WXWQ
<b>1133</b>	.625	1.00	.188 x .188 x 1.25	.5000	.125 x .125 x 1.44	.25	1.33	3.90	.53	4.75	.32	5.32	7.16	3.56	.25	1.19	30	34	29	30	34	29
<b>1154</b>	.625	1.00	.188 x .188 x 1.25	.5000	.125 x .125 x 1.44	.25	1.33	4.61	.51	5.42	.30	5.85	7.69	4.38	.29	1.87	36	40	35	36	40	35
<b>1175</b>	1.000	1.44	.250 x .250 x 2.50	.5000	.125 x .125 x 1.44	.25	1.33	4.73	.49	5.50	.28	5.94	7.79	4.38	.25	1.63	38	42	37	38	42	37
<b>1206</b>	1.438	1.94	.375 x .375 x 3.00	.5000	.125 x .125 x 1.44	.38	1.33	4.99	.61	6.00	.40	6.32	8.16	4.88	.13	1.88	47	51	46	47	51	46
<b>1238</b>	1.438	1.94	.375 x .375 x 3.00	.5000	.125 x .125 x 1.44	.38	1.33	5.18	.51	6.00	.31	6.44	8.29	5.25	.38	2.25	63	67	60	63	67	60
<b>1262</b>	1.438	1.94	.375 x .375 x 3.00	.5000	.125 x .125 x 1.44	.38	1.33	6.01	.60	7.00	.39	7.01	8.85	5.56	.13	2.06	79	83	76	79	83	76
<b>1300</b>	1.938	2.51	.500 x .500 x 3.00	.6250	.188 x .188 x 1.50	.38	1.54	6.53	.60	7.50	.36	7.86	10.06	5.88	.19	2.13	107	111	104	107	111	104
<b>1325</b>	1.938	2.51	.500 x .500 x 3.00	.6250	.188 x .188 x 1.50	.38	1.54	7.04	.54	7.88	.29	8.05	10.25	6.25	.75	2.31	120	122	115	120	122	115
<b>1425</b>	2.188	2.75	.500 x .500 x 3.00	.6250	.188 x .188 x 1.50	.50	2.06	7.53	.63	8.50	.34	9.18	11.57	7.50	.75	3.25	194	198	191	194	198	191
<b>1525</b>	3.438	4.26	.875 x .875 x 4.00	.7500	.188 x .188 x 1.75	.50	2.63	8.85	.97	10.50	.68	11.57	14.47	9.16	-.09	3.91	326	327	318	326	327	318
<b>1600</b>	3.438	4.18	.875 x .875 x 4.00	.8750	.188 x .188 x 1.75	.50	3.25	10.52	.52	11.50	.52	13.30	16.70	9.63	1.56	3.88	431	442	427	431	442	427
<b>1700</b>	3.938	4.92	1.000 x 1.000 x 7.00	.8750	.188 x .188 x 1.75	.75	3.25	11.36	1.09	13.50	1.09	12.96	16.90	...	.25	...	553	564	549	553	564	549
<b>1800</b>	4.438	5.55	1.000 x 1.000 x 7.00	1.2500	.250 x .250 x 2.88	.75	4.25	12.48	1.03	14.50	1.03	13.94	18.19	...	.75	...	806	814	796	806	814	796
<b>11000</b>	5.438	6.67	1.250 x 1.250 x 12.00	1.2500	.250 x .250 x 3.00	1.00	5.25	15.78	1.39	18.50	1.39	17.05	22.30	...	-.25	...	1307	1314	1292	1307	1314	1292

# Assemblies \*

Reverse all arrows for opposite rotation of high speed shaft.  
 Shaft rotation is viewed by looking at each shaft extension.

## SIZES 1133-1600

## SIZES 1700-11000

**WXWM  
&  
WXWF**

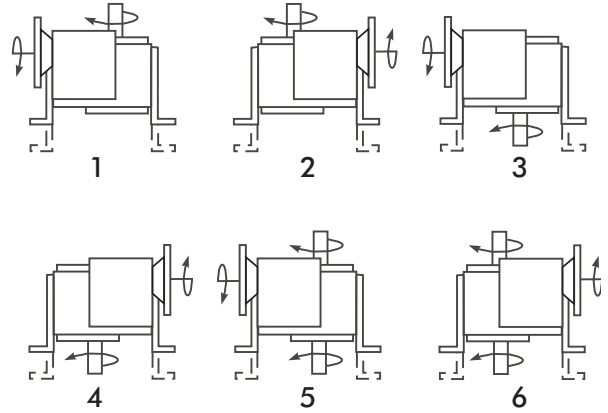
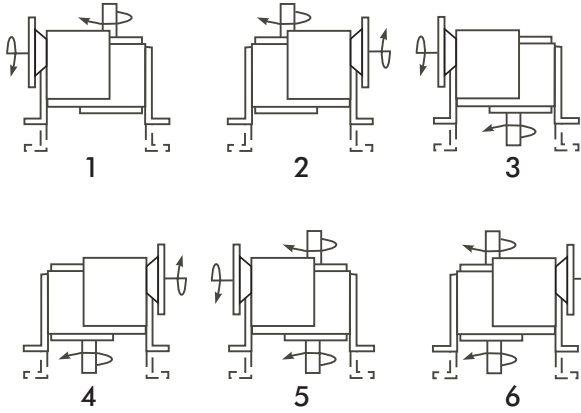

**WXWQ  
M  
&  
WXWQF**

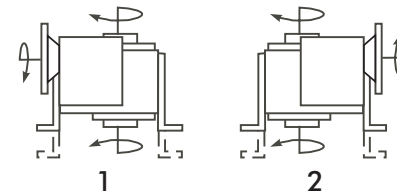
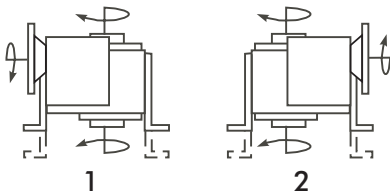

**WXW**

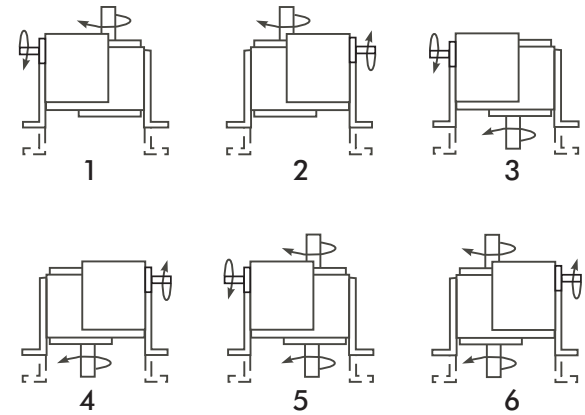
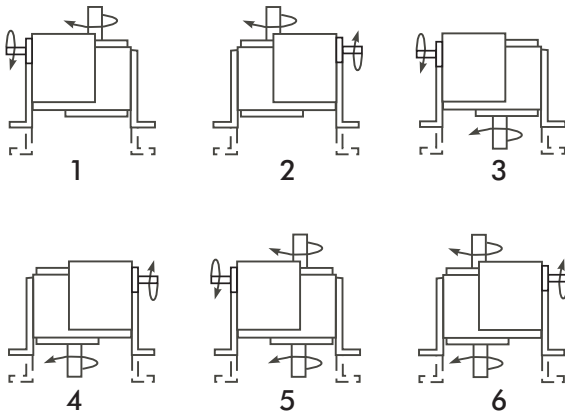

**WXWQ**

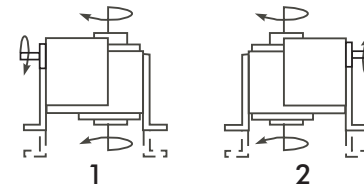
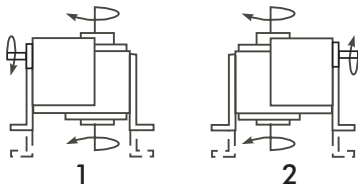

(See Page 5 for footnotes.)



# Motor Data

## NEMA Motor Flange Face Locations — Inches

DRIVE SIZE	56C/140TC		180TC		210TC		250TC	
	LA	LC	LB	LD	LB	LD	LB	LD
1133	3.46	6.07	...	...	...	...	...	...
1154	3.46	6.07	...	...	...	...	...	...
1175	3.46	6.07	...	...	...	...	...	...
1206	3.46	6.07	...	...	...	...	...	...
1238	3.46	6.07	...	...	...	...	...	...
1262	3.46	6.07	...	...	...	...	...	...
1300	3.99	6.60	...	...	...	...	...	...
1325	3.99	6.60	...	...	...	...	...	...
1425	4.46	7.07	...	...	...	...	...	...
1525	5.19	8.32	5.62	9.32	...	9.32	...	...
1600	5.88	9.01	6.31	10.01	6.75	10.01	...	...
1700	5.88	9.01	6.31	10.01	6.75	10.01	...	...
1800	6.45	11.81	7.21	12.90	7.21	12.90	7.77	13.46
11000	7.85	13.21	8.61	14.30	8.61	14.30	9.17	14.86

## NEMA Motor Mounting Dimensions — Inches

FRAME SIZE	AJ	AK	BA	BB	BD	BF	BG	UA	Keyway
56C	5.88	4.50	.38	...	5.88	.41	6.64	.625	.1875 x .0938
140TC	5.88	4.50	.38	...	5.88	.41	6.64	.875	.1875 x .0938
180TC	7.25	8.50	...	.50	9.00	.53	...	1.125	.2500 x .1250
210TC	7.25	8.50	...	.50	9.00	.53	...	1.375	.3125 x .1562
250TC	7.25	8.50	...	.50	9.00	.53	...	1.625	.3750 x .1875

## IEC B5 & B3/B5 Motor Flange Dimensions \* — Inches

DRIVE SIZE	D63D	D71D	D80D	D90D	D100LD/D112MD	D132D
	LA	LA	LA	LA	LA	LA
1133	2.62	2.65	2.89	...	...	...
1154	2.62	2.65	2.89	...	...	...
1175	2.62	2.65	2.89	...	...	...
1206	2.62	2.65	2.89	...	...	...
1238	2.62	2.65	2.89	...	...	...
1262	2.62	2.65	2.89	...	...	...
1300	3.15	3.18	3.42	...	...	...
1325	3.15	3.18	3.42	...	...	...
1425	3.62	3.65	3.89	...	...	...
1525	...	4.28	4.90	4.90	5.30	...
1600	...	4.97	5.59	5.59	5.99	...
1700	...	4.97	5.59	5.59	5.99	...
1800	...	...	...	6.38	6.39	7.17
11000	...	...	...	7.78	7.78	8.57

## IEC B5 & B3/B5 Metric Motor Mounting Dimensions — Millimeters

FRAME SIZE	AJ	AK	BA	BD	BF	BG	UA	Keyway
D63D	115	95	10	117	M8 x 1.25	131	11	4 x 2.0
D71D	130	110	11	132	M8 x 1.25	146	14	5 x 2.5
D80D	165	130	15	165	M10 x 1.50	184	19	6 x 3.0
D90D	165	130	15	165	M10 x 1.50	184	24	8 x 3.5
D100LD/D112MD	215	180	18	216	M12 x 1.75	237	28	8 x 3.5
D132D	265	230	18	267	M12 x 1.75	290	38	10 x 4.0

(See Page 5 for footnotes.)

# Double Reduction/Worm-Worm/Vertical Input

## Dimensions — Inches

Type  
**WJWM**

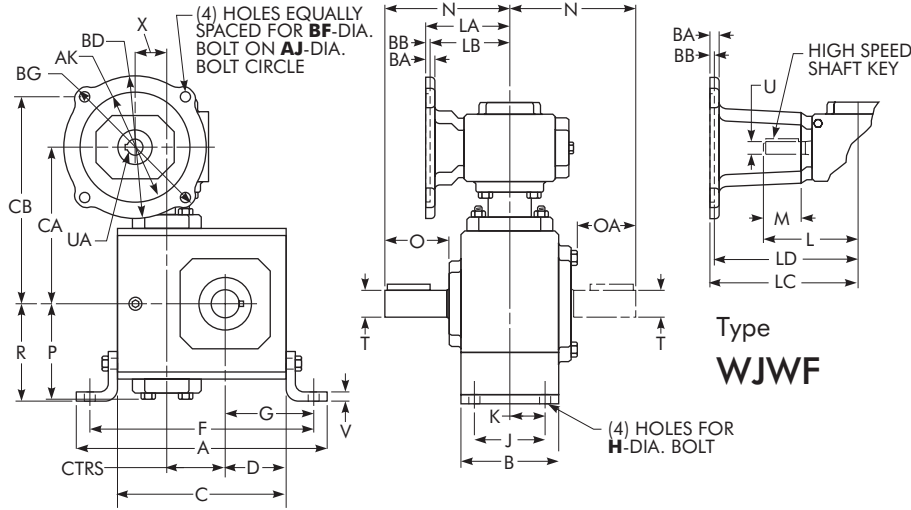

Type  
**WJWF**

Type  
**WJW**

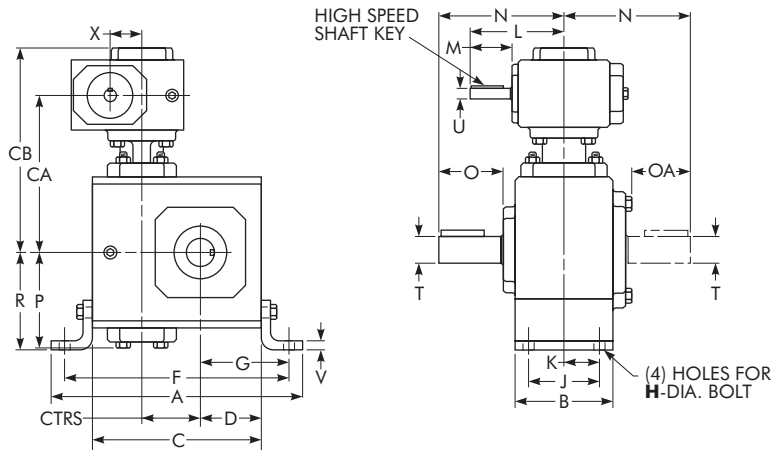

SEE PAGE 77 FOR MOTOR MOUNTING DIMENSIONS.

(Continued on next page)

DRIVE SIZE ★	CTRS	A	B	C	D	F	G	H	J	K	L	M •	N	O ♦	OA ♦	P	R	Low Speed Shaft	
																		T	Key
																		-.0005 -.0015	
<b>1133</b>	1.33	7.42	2.75	4.66	1.72	6.42	2.60	.38	2.00	1.00	3.82	1.76	4.00	2.16	1.94	2.61	2.94	.6250	.188 x .188 x 1.50
<b>1154</b>	1.54	8.14	3.50	5.38	1.91	7.08	2.76	.44	2.75	1.38	3.82	1.76	4.31	2.11	1.90	3.14	3.50	.7500	.188 x .188 x 1.50
<b>1175</b>	1.75	8.51	3.50	5.75	2.06	7.45	2.91	.44	2.75	1.38	3.82	1.76	4.31	2.05	1.84	3.24	3.50	.8750	.188 x .188 x 1.38
<b>1206</b>	2.06	9.76	4.00	6.38	2.28	8.62	3.40	.50	2.75	1.38	3.82	1.76	4.68	2.29	2.08	3.61	4.01	1.0000	.250 x .250 x 1.44
<b>1238</b>	2.38	10.31	4.00	6.94	2.50	9.19	3.63	.50	2.88	1.44	3.82	1.76	5.14	2.66	2.44	3.77	4.06	1.1250	.250 x .250 x 1.75
<b>1262</b>	2.63	11.62	5.00	8.00	2.94	10.38	4.13	.56	3.38	1.69	3.82	1.76	5.63	2.73	2.52	4.34	5.00	1.1250	.250 x .250 x 1.44
<b>1300</b>	3.00	12.64	6.00	8.88	3.25	11.38	4.50	.56	3.88	1.94	4.35	1.76	6.75	3.60	3.36	4.84	5.62	1.2500	.250 x .250 x 2.25
<b>1325</b>	3.25	13.14	6.00	9.38	3.50	11.88	4.75	.56	3.88	1.94	4.35	1.76	7.06	3.66	3.42	5.02	5.63	1.3750	.313 x .313 x 2.50
<b>1425</b>	4.25	16.38	7.00	11.38	4.44	14.88	6.19	.69	5.00	2.50	4.82	1.76	8.12	4.50	4.21	6.10	6.50	1.8750	.500 x .500 x 3.06
<b>1525</b>	5.25	19.00	7.00	14.00	5.12	17.50	6.87	.69	5.81	2.91	6.07	2.38	9.06	4.78	4.53	7.50	7.75	2.0000	.500 x .500 x 3.50

(See Page 5 for footnotes.)

Type  
**WJWQM**

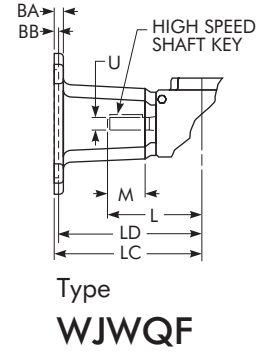
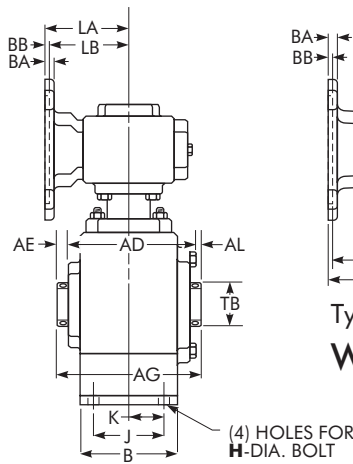
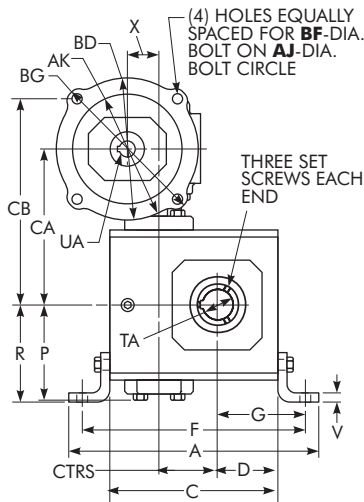

Type  
**WJWQF**

Type  
**WJWQ**

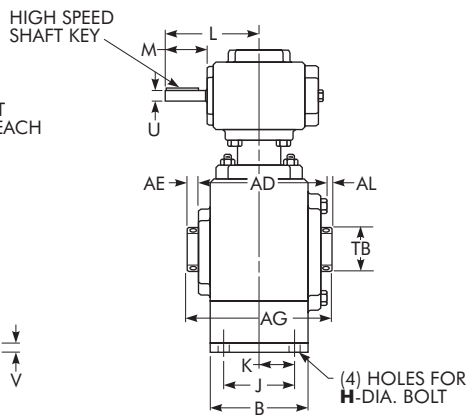
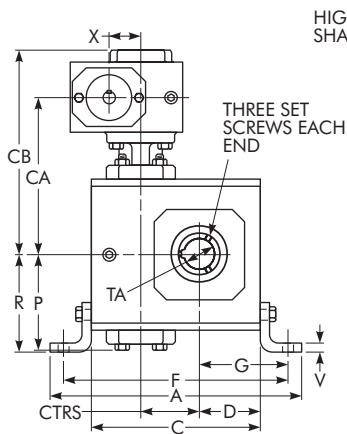

SEE PAGE 77 FOR MOTOR MOUNTING DIMENSIONS.

(Continued from preceding page)

DRIVE SIZE ★	Hollow Low Speed Shaft			High Speed Shaft		V	X	AD	AE	AG	AL	CA	CB	Approx. Wt – lb					
	TA Max = +.002 -.000	TB	Key	U -.0005 -.0015	Key									WJWM	WJWF	WJW	WJWQM	WJWQF	WJWQ
1133	.625	1.00	.188 x .188 x 1.25	.5000	.125 x .125 x 1.44	.25	1.33	3.90	.53	4.75	.32	5.32	7.16	27	31	26	27	31	26
1154	.625	1.00	.188 x .188 x 1.25	.5000	.125 x .125 x 1.44	.25	1.33	4.61	.51	5.42	.30	5.85	7.69	34	38	33	34	38	33
1175	1.000	1.44	.250 x .250 x 2.50	.5000	.125 x .125 x 1.44	.25	1.33	4.73	.49	5.50	.28	5.94	7.79	36	40	35	37	41	36
1206	1.438	1.94	.375 x .375 x 3.00	.5000	.125 x .125 x 1.44	.38	1.33	4.99	.61	6.00	.40	6.32	8.16	42	46	41	45	49	44
1238	1.438	1.94	.375 x .375 x 3.00	.5000	.125 x .125 x 1.44	.38	1.33	5.18	.51	6.00	.31	6.44	8.29	58	62	55	59	63	56
1262	1.438	1.94	.375 x .375 x 3.00	.5000	.125 x .125 x 1.44	.38	1.33	6.01	.60	7.00	.39	7.01	8.85	78	82	75	76	80	73
1300	1.938	2.51	.500 x .500 x 3.00	.6250	.188 x .188 x 1.50	.38	1.54	6.53	.60	7.50	.36	7.86	10.06	99	103	96	99	103	96
1325	1.938	2.51	.500 x .500 x 3.00	.6250	.188 x .188 x 1.50	.38	1.54	7.04	.54	7.88	.29	8.05	10.25	109	114	107	109	114	107
1425	2.188	2.75	.500 x .500 x 3.00	.6250	.188 x .188 x 1.50	.50	2.06	7.53	.63	8.50	.34	9.18	11.57	207	211	204	207	211	204
1525	3.438	4.26	.875 x .875 x 4.00	.7500	.188 x .188 x 1.75	.50	2.63	8.85	.97	10.50	.68	11.57	14.47	309	310	301	309	310	301

# Assemblies \*

Reverse all arrows for opposite rotation of high speed shaft.  
Shaft rotation is viewed by looking at each shaft extension.

## SIZES 1133-1600

**WJWM  
&  
WJWF**

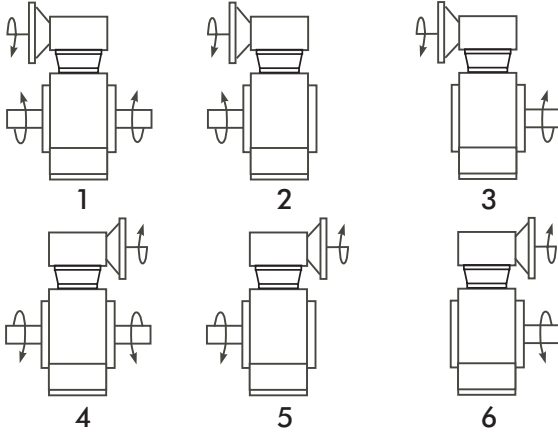

**WJWQM  
&  
WJWQF**

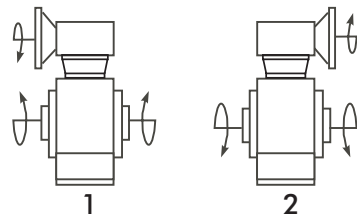

**WJW**

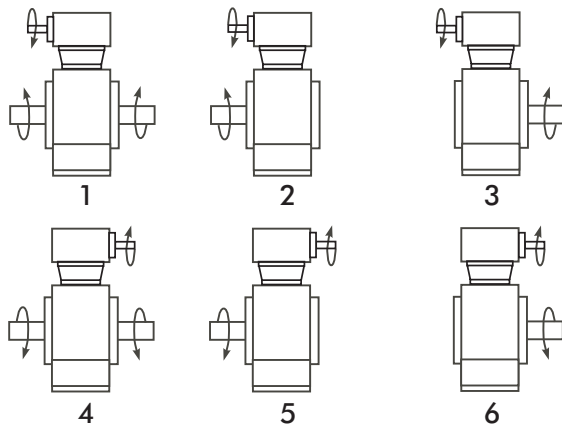

**WJWQ**

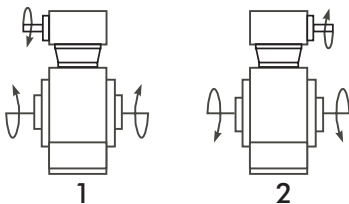

(See Page 5 for footnotes.)

# Motor Data

## NEMA Motor Flange Face Locations — Inches

DRIVE SIZE	56C/140TC		180TC		210TC	
	LA	LC	LB	LD	LB	LD
1133	3.46	6.07	...	...	...	...
1154	3.46	6.07	...	...	...	...
1175	3.46	6.07	...	...	...	...
1206	3.46	6.07	...	...	...	...
1238	3.46	6.07	...	...	...	...
1262	3.46	6.07	...	...	...	...
1300	3.99	6.60	...	...	...	...
1325	3.99	6.60	...	...	...	...
1425	4.46	7.07	...	...	...	...
1525	5.19	8.32	5.62	9.32	...	9.32

## NEMA Motor Mounting Dimensions — Inches

FRAME SIZE	AJ	AK	BA	BB	BD	BF	BG	UA	Keyway
56C	5.88	4.50	.38	...	5.88	.41	6.64	.625	.1875 x .0938
140TC	5.88	4.50	.38	...	5.88	.41	6.64	.875	.1875 x .0938
180TC	7.25	8.50	...	.50	9.00	.53	...	1.125	.2500 x .1250
210TC	7.25	8.50	...	.50	9.00	.53	...	1.375	.3125 x .1562

## IEC B5 & B3/B5 Motor Flange Dimensions \* — Inches

DRIVE SIZE	D63D	D71D	D80D	D90D	D100LD/D112MD
	LA	LA	LA	LA	LA
1133	2.62	2.65	2.89	...	...
1154	2.62	2.65	2.89	...	...
1175	2.62	2.65	2.89	...	...
1206	2.62	2.65	2.89	...	...
1238	2.62	2.65	2.89	...	...
1262	2.62	2.65	2.89	...	...
1300	3.15	3.18	3.42	...	...
1325	3.15	3.18	3.42	...	...
1425	3.62	3.65	3.89	...	...
1525	...	4.28	4.90	4.90	5.30

## IEC B5 & B3/B5 Metric Motor Mounting Dimensions — Millimeters

FRAME SIZE	AJ	AK	BA	BD	BF	BG	UA	Keyway
D63D	115	95	10	117	M8 x 1.25	131	11	4 x 2.0
D71D	130	110	11	132	M8 x 1.25	146	14	5 x 2.5
D80D	165	130	15	165	M10 x 1.50	184	19	6 x 3.0
D90D	165	130	15	165	M10 x 1.50	184	24	8 x 3.5
D100LD/D112MD	215	180	18	216	M12 x 1.75	237	28	8 x 3.5

(See Page 5 for footnotes.)

# Double Reduction/Worm-Worm/Flanged Output

Dimensions — Inches

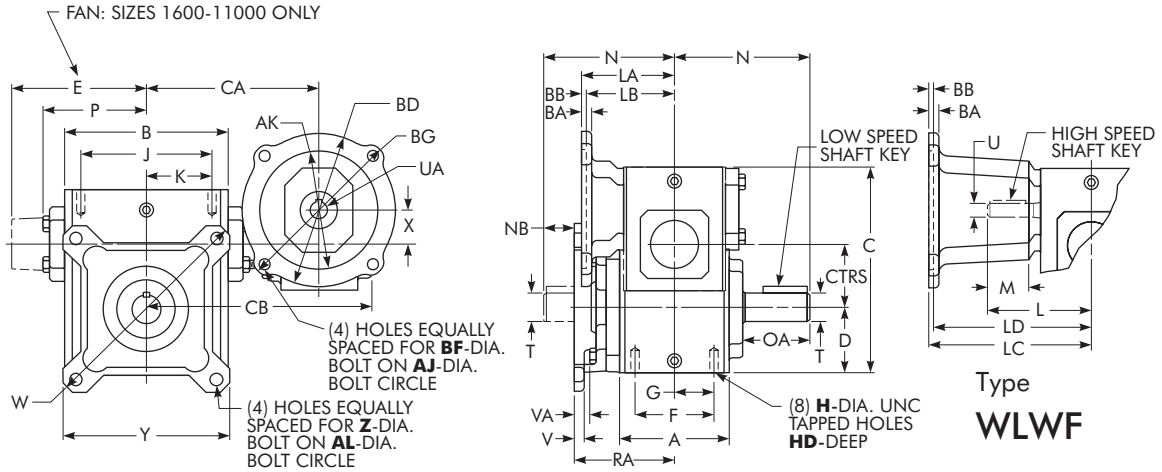

Type  
**WLWM**

Type  
**WLWF**

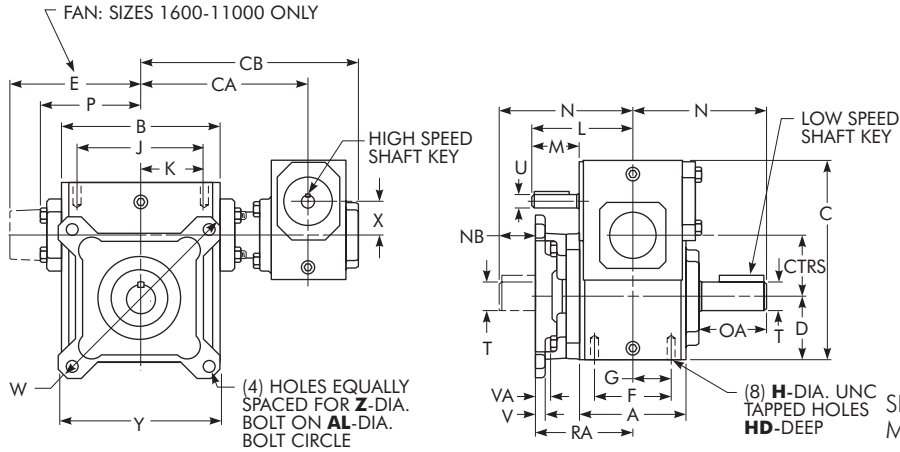

Type  
**WLW**

SEE PAGE 81 FOR MOTOR MOUNTING DIMENSIONS.

(Continued on next page)

DRIVE SIZE *	CTRS	A	B	C	D	E	F	G	H	HD	J	K	L	M •	N	OA •	P	R	Low Speed Shaft		Hollow Low Speed Shaft		
																			T	Key	TA Max ■	Key	
																			-.0005 -.0015		+.002 -.000		
1133	1.33	2.82	3.80	5.99	1.72	...	2.00	1.00	.3125-18	.50	3.25	1.63	3.82	1.76	4.00	2.16	2.61	1.48	.6250	.188 x .188 x 1.50	.625	1.00	.188 x .188 x 1.25
1154	1.54	3.44	4.88	6.38	1.91	...	2.75	1.38	.3125-18	.63	4.19	2.09	3.82	1.76	4.31	2.11	3.14	1.44	.7500	.188 x .188 x 1.50	.625	1.00	.188 x .188 x 1.25
1175	1.75	3.56	5.06	6.75	2.06	...	2.75	1.38	.3125-18	.63	4.19	2.09	3.82	1.76	4.31	2.05	3.24	1.13	.8750	.188 x .188 x 1.38	1.000	1.44	.250 x .250 x 2.50
1206	2.06	3.81	5.80	7.28	2.28	...	3.00	1.50	.3125-18	.63	4.75	2.38	3.82	1.76	4.68	2.29	3.61	.99	1.0000	.250 x .250 x 1.44	1.438	1.94	.375 x .375 x 3.00
1238	2.38	4.06	6.12	7.81	2.50	...	2.88	1.44	.3750-16	.56	5.00	2.50	3.82	1.76	5.14	2.66	3.77	1.47	1.1250	.250 x .250 x 1.75	1.438	1.94	.375 x .375 x 3.00
1262	2.63	4.84	7.12	8.50	2.94	...	3.38	1.69	.3750-16	.69	6.38	3.19	3.82	1.76	5.63	2.73	4.34	1.99	1.1250	.250 x .250 x 1.44	1.438	1.94	.375 x .375 x 3.00
1300	3.00	5.25	8.12	9.72	3.25	...	4.00	2.00	.4375-14	.88	7.00	3.50	4.35	1.76	6.75	3.60	4.84	3.03	1.2500	.250 x .250 x 2.25	1.938	2.51	.500 x .500 x 3.00
1325	3.25	5.75	8.50	10.22	3.50	...	4.00	2.00	.4375-14	.88	7.50	3.75	4.35	1.76	7.06	3.66	5.02	3.08	1.3750	.313 x .313 x 2.50	1.938	2.51	.500 x .500 x 3.00
1425	4.25	6.13	10.25	12.78	4.44	...	5.00	2.50	.6250-11	1.00	8.50	4.25	4.82	1.76	8.12	4.50	6.10	3.62	1.8750	.500 x .500 x 3.06	2.188	2.75	.500 x .500 x 3.00
1525	5.25	7.19	13.00	15.43	5.12	...	5.81	2.91	.6250-11	1.25	11.00	5.50	6.07	2.38	9.06	4.78	7.50	3.50	2.0000	.500 x .500 x 3.50	3.438	4.26	.875 x .875 x 4.00
1600	6.00	8.13	14.25	18.38	6.50	10.24	6.38	3.19	.6250-11	1.00	12.75	6.38	6.76	2.38	10.00	4.66	...	2.78	2.2500	.500 x .500 x 4.00	3.438	4.18	.875 x .875 x 4.00
1700	7.00	7.63	14.88	20.46	7.59	10.63	5.50	2.75	1.0000-8	1.56	12.50	6.25	6.76	2.38	11.76	5.69	...	4.32	2.7500	.625 x .625 x 4.00	3.938	4.92	1.000 x 1.000 x 7.00
1800	8.00	8.63	17.00	23.79	8.86	11.93	6.50	3.25	1.0000-8	1.66	14.25	7.13	9.57	3.47	12.25	6.02	...	3.92	3.0000	.750 x .750 x 4.50	4.438	5.55	1.000 x 1.000 x 7.00
11000	10.00	9.53	20.88	29.24	10.36	14.34	6.88	3.44	1.2500-7	2.04	17.75	8.88	10.88	3.38	14.75	6.80	...	5.70	3.7500	.875 x .875 x 5.00	5.438	6.67	1.250 x 1.250 x 12.00

(See Page 5 for footnotes.)

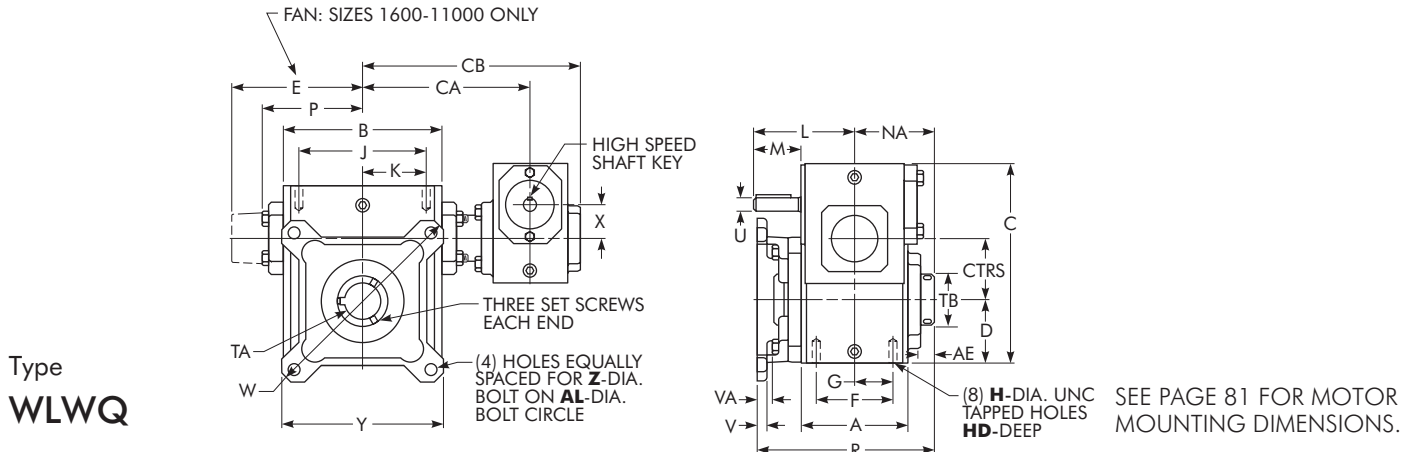
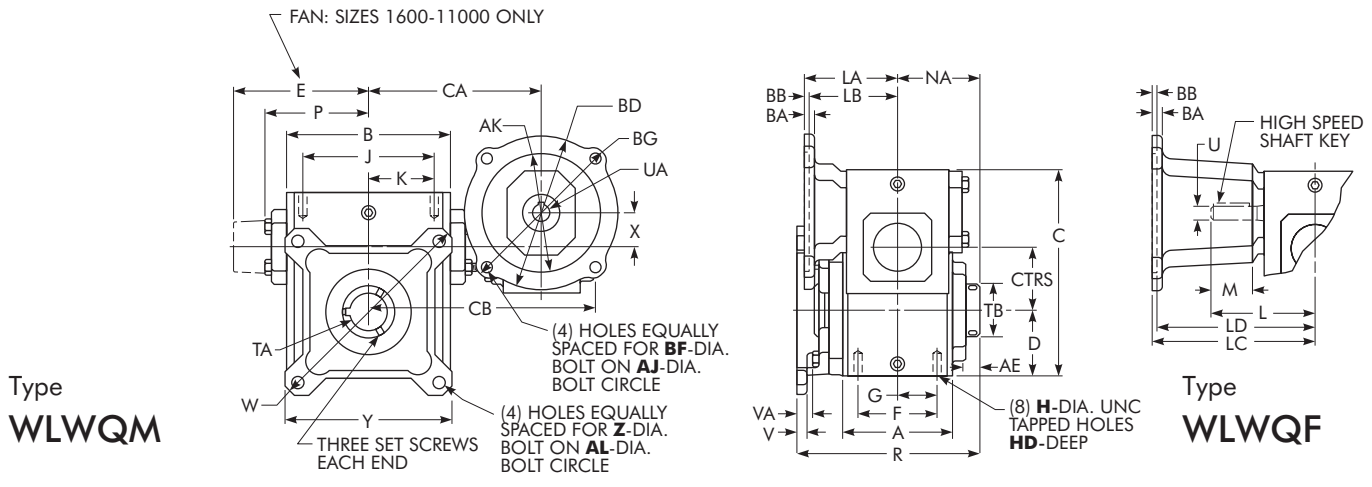

(Continued from preceding page)

DRIVE SIZE ★	High Speed Shaft		V	W	X	Y	Z	AE	AL	CA	CB	NA	NB	RA	VA	Approx. Wt - lb					
	U -.0005 -.0015	Key														WLWM	WLWF	WLW	WLWQM	WLWQF	WLWQ
<b>1133</b>	.5000	.125 x .125 x 1.44	.38	5.92	1.33	4.50	.34	.53	5.00	5.32	7.16	2.38	1.48	2.52	.08	29	33	28	29	33	28
<b>1154</b>	.5000	.125 x .125 x 1.44	.38	5.92	1.33	4.50	.34	.51	5.00	5.85	7.69	2.71	.30	2.87	.08	34	38	33	34	38	33
<b>1175</b>	.5000	.125 x .125 x 1.44	.38	6.64	1.33	5.00	.34	.49	5.88	5.94	7.79	2.75	1.13	3.18	.11	37	41	36	38	42	37
<b>1206</b>	.5000	.125 x .125 x 1.44	.44	7.88	1.33	5.99	.41	.61	7.00	6.32	8.16	3.00	.99	3.69	.55	43	47	42	46	50	45
<b>1238</b>	.5000	.125 x .125 x 1.44	.44	8.39	1.33	6.27	.41	.51	7.50	6.44	8.29	3.00	1.47	3.67	.51	65	69	62	66	67	63
<b>1262</b>	.5000	.125 x .125 x 1.44	.50	8.88	1.33	6.67	.41	.60	8.00	7.01	8.85	3.50	1.99	3.64	.04	78	82	75	76	80	73
<b>1300</b>	.6250	.188 x .188 x 1.50	.50	9.89	1.54	7.37	.41	.60	9.00	7.86	10.06	3.75	3.03	3.72	.07	109	113	106	109	113	106
<b>1325</b>	.6250	.188 x .188 x 1.50	.50	9.89	1.54	7.37	.41	.54	9.00	8.05	10.25	3.94	3.08	3.98	.07	119	124	117	119	124	117
<b>1425</b>	.6250	.188 x .188 x 1.50	.62	12.95	2.06	9.65	.56	.63	11.50	9.18	11.57	4.25	3.62	4.50	.06	178	182	175	178	182	175
<b>1525</b>	.7500	.188 x .188 x 1.75	.75	15.50	2.63	11.75	.69	.97	14.00	11.57	14.47	5.25	3.50	5.56	.34	309	310	301	309	310	301
<b>1600</b>	.8750	.188 x .188 x 1.75	.75	18.00	3.25	6.87	.69	.52	15.63	13.30	16.70	5.75	2.78	7.22	1.38	416	427	412	416	427	412
<b>1700</b>	.8750	.188 x .188 x 1.75	.75	21.00	3.25	7.82	.78	1.09	18.38	12.96	16.90	6.75	4.32	7.44	1.57	497	508	493	497	508	493
<b>1800</b>	1.2500	.250 x .250 x 2.88	.75	24.00	4.25	8.94	1.03	1.03	21.00	13.94	18.19	7.25	3.92	8.33	1.89	746	754	736	746	754	736
<b>11000</b>	1.2500	.250 x .250 x 3.00	1.00	29.00	5.25	10.60	1.03	1.39	25.00	17.05	22.30	9.25	5.70	9.05	1.85	1172	1179	1157	1172	1179	1157

# Assemblies \*

Reverse all arrows for opposite rotation of high speed shaft.  
 Shaft rotation is viewed by looking at each shaft extension.

SIZES 1133-1600

SIZES 1700-11000

WLWM  
&  
WLWF

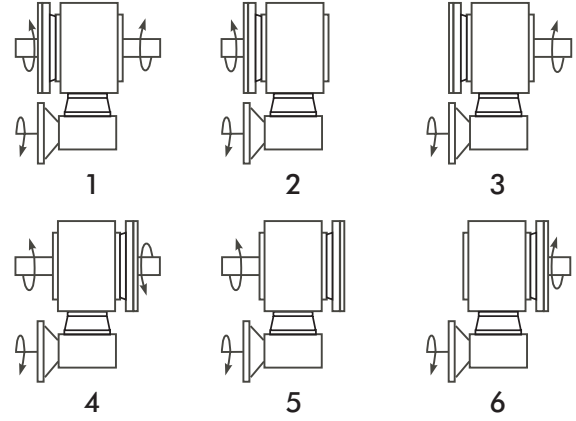
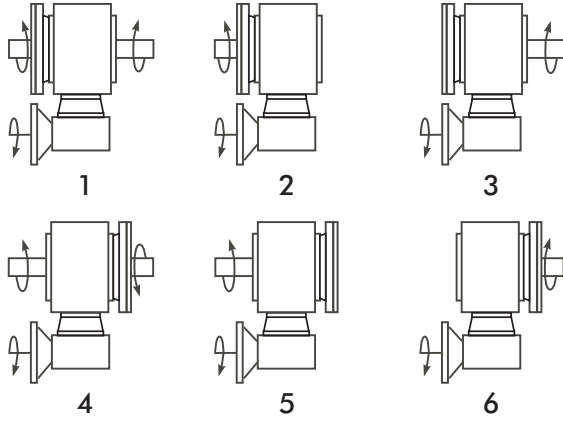

WLWQM  
&  
WLWQF

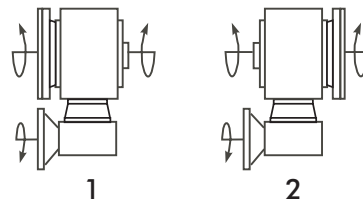
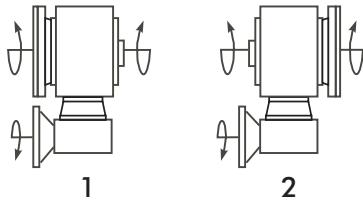

WLW

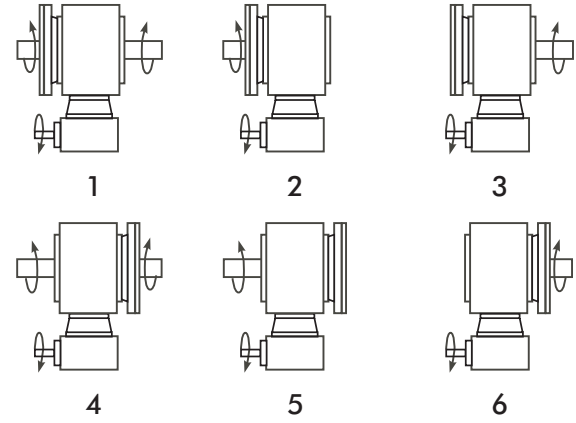
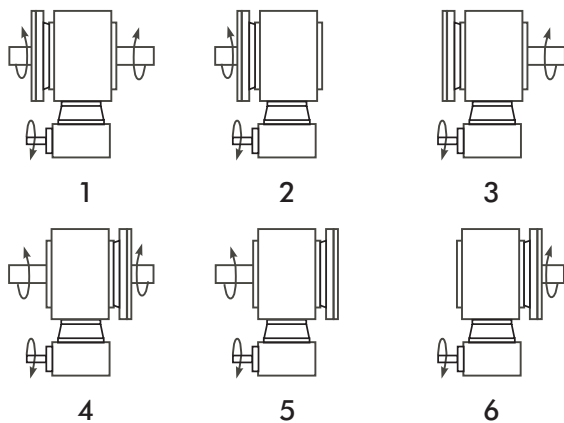

WLWQ

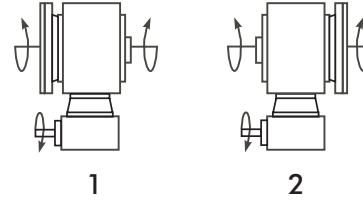
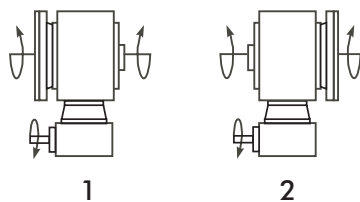

(See Page 5 for footnotes.)



# Motor Data

## NEMA Motor Flange Face Locations — Inches

DRIVE SIZE	56C/140TC		180TC		210TC		250TC	
	LA	LC	LB	LD	LB	LD	LB	LD
1133	3.46	6.07	...	...	...	...	...	...
1154	3.46	6.07	...	...	...	...	...	...
1175	3.46	6.07	...	...	...	...	...	...
1206	3.46	6.07	...	...	...	...	...	...
1238	3.46	6.07	...	...	...	...	...	...
1262	3.46	6.07	...	...	...	...	...	...
1300	3.99	6.60	...	...	...	...	...	...
1325	3.99	6.60	...	...	...	...	...	...
1425	4.46	7.07	...	...	...	...	...	...
1525	5.19	8.32	5.62	9.32	...	9.32	...	...
1600	5.88	9.01	6.31	10.01	6.75	10.01	...	...
1700	5.88	9.01	6.31	10.01	6.75	10.01	...	...
1800	6.45	11.81	7.21	12.90	7.21	12.90	7.77	13.46
11000	7.85	13.21	8.61	14.30	8.61	14.30	9.17	14.86

## NEMA Motor Mounting Dimensions — Inches

FRAME SIZE	AJ	AK	BA	BB	BD	BF	BG	UA	Keyway
56C	5.88	4.50	.38	...	5.88	.41	6.64	.625	.1875 x .0938
140TC	5.88	4.50	.38	...	5.88	.41	6.64	.875	.1875 x .0938
180TC	7.25	8.50	...	.50	9.00	.53	...	1.125	2500 x .1250
210TC	7.25	8.50	...	.50	9.00	.53	...	1.375	.3125 x .1562
250TC	7.25	8.50	...	.50	9.00	.53	...	1.625	.3750 x .1875

## IEC B5 & B3/B5 Motor Flange Dimensions \* — Inches

DRIVE SIZE	D63D	D71D	D80D	D90D	D100LD/D112MD	D132D
	LA	LA	LA	LA	LA	LA
1133	2.62	2.65	2.89	...	...	...
1154	2.62	2.65	2.89	...	...	...
1175	2.62	2.65	2.89	...	...	...
1206	2.62	2.65	2.89	...	...	...
1238	2.62	2.65	2.89	...	...	...
1262	2.62	2.65	2.89	...	...	...
1300	3.15	3.18	3.42	...	...	...
1325	3.15	3.18	3.42	...	...	...
1425	3.62	3.65	3.89	...	...	...
1525	...	4.28	4.90	4.90	5.30	...
1600	...	4.97	5.59	5.59	5.99	...
1700	...	4.97	5.59	5.59	5.99	...
1800	...	...	...	6.38	6.39	7.17
11000	...	...	...	7.78	7.78	8.57

## IEC B5 & B3/B5 Metric Motor Mounting Dimensions — Millimeters

FRAME SIZE	AJ	AK	BA	BD	BF	BG	UA	Keyway
D63D	115	95	10	117	M8 x 1.25	131	11	4 x 2.0
D71D	130	110	11	132	M8 x 1.25	146	14	5 x 2.5
D80D	165	130	15	165	M10 x 1.50	184	19	6 x 3.0
D90D	165	130	15	165	M10 x 1.50	184	24	8 x 3.5
D100LD/D112MD	215	180	18	216	M12 x 1.75	237	28	8 x 3.5
D132D	265	230	18	267	M12 x 1.75	290	38	10 x 4.0

(See Page 5 for footnotes.)

# Horsepower and Torque Ratings/Double Reduction

## Helical-Worm

Nominal Ratio	SPEED (rpm)		SIZE 1133			SIZE 1154			SIZE 1175		
	Input	Approx. Output	Horsepower		Output Torque (lb-in)	Horsepower		Output Torque (lb-in)	Horsepower		Output Torque (lb-in)
			Input	Output		Input	Output		Input	Output	
10	1750	175	0.684	0.589	212	1.120	0.964	347	1.180	1.030	372
	1170	117	0.499	0.423	228	0.834	0.705	380	0.882	0.759	409
	870	87.0	0.390	0.326	236	0.659	0.549	398	0.697	0.592	429
15	1750	117	0.541	0.459	248	0.854	0.709	383	1.080	0.940	508
	1170	78.0	0.389	0.324	262	0.638	0.517	418	0.792	0.675	545
	870	58.0	0.302	0.249	270	0.506	0.402	437	0.618	0.521	566
20	1750	87.5	0.463	0.378	272	0.708	0.564	406	0.867	0.739	532
	1170	58.5	0.335	0.267	288	0.532	0.410	442	0.628	0.525	566
	870	43.5	0.261	0.205	297	0.423	0.320	463	0.489	0.404	585
25	1750	70.0	0.323	0.268	241	0.548	0.454	409	0.579	0.49	441
	1170	46.8	0.225	0.184	248	0.388	0.315	424	0.409	0.34	458
	870	34.8	0.172	0.139	252	0.298	0.239	433	0.314	0.257	466
30	1750	58.3	0.351	0.268	290	0.546	0.400	432	0.669	0.535	578
	1170	39.0	0.257	0.190	307	0.413	0.291	470	0.491	0.382	617
	870	29.0	0.201	0.145	316	0.33	0.226	492	0.385	0.294	639
40	1750	43.8	0.263	0.206	297	0.426	0.321	462	0.492	0.405	584
	1170	29.2	0.186	0.142	306	0.306	0.224	483	0.346	0.280	603
	870	21.8	0.142	0.107	310	0.238	0.170	493	0.264	0.211	612
45	1750	38.9	0.257	0.189	307	0.415	0.291	471	0.492	0.381	618
	1170	26.0	0.184	0.132	319	0.305	0.205	498	0.353	0.266	645
	870	19.3	0.143	0.100	325	0.240	0.157	513	0.274	0.203	660
50	1750	35.0	0.216	0.168	302	0.353	0.263	474	0.403	0.330	595
	1170	23.4	0.151	0.115	309	0.252	0.182	491	0.281	0.227	610
	870	17.4	0.115	0.086	313	0.194	0.138	500	0.214	0.171	618
60	1750	29.2	0.202	0.146	316	0.333	0.227	491	0.388	0.295	638
	1170	19.5	0.143	0.101	325	0.241	0.159	513	0.275	0.204	660
	870	14.5	0.110	0.076	330	0.188	0.121	524	0.212	0.154	671
75	1750	23.3	0.166	0.119	321	0.277	0.187	504	0.319	0.241	651
	1170	15.6	0.117	0.081	329	0.199	0.129	522	0.225	0.166	669
	870	11.6	0.090	0.061	333	0.155	0.098	531	0.172	0.125	678
80	1750	21.8	0.160	0.109	315	0.277	0.175	505	0.300	0.220	634
	1170	14.6	0.113	0.075	323	0.202	0.122	526	0.212	0.152	653
	870	10.9	0.087	0.057	328	0.158	0.093	538	0.163	0.114	663
100	1750	17.5	0.143	0.090	323	0.232	0.144	518	0.246	0.179	646
	1170	11.7	0.103	0.062	332	0.167	0.099	535	0.173	0.123	661
	870	8.70	0.079	0.047	337	0.130	0.075	544	0.133	0.092	669
125	1750	14.0	0.119	0.073	329	0.200	0.115	519	0.200	0.140	629
	1170	9.36	0.084	0.050	336	0.145	0.080	536	0.141	0.095	642
	870	6.96	0.065	0.038	340	0.113	0.060	545	0.108	0.072	650
150	1750	11.7	0.106	0.061	329	0.185	0.096	516	0.198	0.124	667
	1170	7.80	0.076	0.042	336	0.135	0.066	533	0.141	0.085	684
	870	5.80	0.058	0.031	340	0.106	0.050	543	0.109	0.064	694
200	1750	8.75	0.084	0.044	318	0.156	0.071	514	0.151	0.089	641
	1170	5.84	0.060	0.030	324	0.114	0.049	531	0.108	0.061	656
	870	4.35	0.047	0.023	328	0.090	0.037	540	0.083	0.046	664
250	1750	7.00	0.068	0.033	299	0.134	0.055	498	0.122	0.067	603
	1170	4.68	0.049	0.023	305	0.099	0.038	514	0.087	0.046	616
	870	3.48	0.038	0.017	308	0.078	0.029	523	0.067	0.034	623
300	1750	5.83	0.060	0.027	287	0.117	0.044	472	0.105	0.053	573
	1170	3.90	0.044	0.018	293	0.087	0.030	487	0.075	0.036	585
	870	2.90	0.034	0.014	296	0.069	0.023	495	0.058	0.027	592

# Horsepower and Torque Ratings/Double Reduction

## Helical-Worm

Nominal Ratio	SPEED (rpm)		SIZE 1206			SIZE 1238			SIZE 1262		
	Input	Approx. Output	Horsepower		Output Torque (lb-in)	Horsepower		Output Torque (lb-in)	Horsepower		Output Torque (lb-in)
			Input	Output		Input	Output		Input	Output	
10	1750	175	1.780	1.540	574	2.92	2.60	935	3.57	3.30	1187
	1170	117	1.200	1.010	564	2.23	1.96	1054	2.75	2.50	1349
	870	87.0	0.895	0.746	558	1.79	1.55	1121	2.21	1.99	1441
15	1750	117	1.610	1.41	762	2.46	2.16	1166	3.09	2.73	1474
	1170	78.0	1.190	1.03	829	1.85	1.60	1289	2.34	2.03	1641
	870	58.0	0.895	0.76	826	1.47	1.25	1357	1.86	1.60	1734
20	1750	87.5	1.360	1.180	847	2.11	1.82	1309	2.73	2.37	1707
	1170	58.5	0.998	0.845	910	1.56	1.32	1426	2.04	1.74	1875
	870	43.5	0.780	0.652	945	1.23	1.03	1491	1.62	1.36	1968
25	1750	70.0	0.907	0.751	699	1.490	1.290	1160	1.86	1.660	1495
	1170	46.8	0.643	0.525	730	1.060	0.904	1217	1.33	1.170	1574
	870	34.8	0.495	0.399	746	0.821	0.689	1247	1.02	0.892	1616
30	1750	58.3	1.000	0.843	911	1.520	1.320	1427	1.99	1.740	1876
	1170	39.0	0.714	0.591	955	1.100	0.935	1511	1.44	1.240	1997
	870	29.0	0.552	0.451	979	0.853	0.716	1556	1.12	0.949	2062
40	1750	43.8	0.786	0.655	944	1.230	1.030	1490	1.610	1.360	1966
	1170	29.2	0.554	0.454	979	0.872	0.722	1555	1.150	0.957	2061
	870	21.8	0.425	0.344	997	0.672	0.549	1590	0.886	0.729	2111
45	1750	38.9	0.749	0.60	973	1.140	0.941	1525	1.40	1.190	1925
	1170	26.0	0.537	0.42	1018	0.826	0.665	1611	1.01	0.836	2026
	870	19.3	0.415	0.32	1043	0.643	0.508	1657	0.78	0.638	2080
50	1750	35.0	0.646	0.536	965	1.020	0.849	1529	1.340	1.120	2023
	1170	23.4	0.452	0.369	993	0.720	0.587	1582	0.949	0.780	2100
	870	17.4	0.345	0.278	1008	0.552	0.445	1610	0.728	0.591	2141
60	1750	29.2	0.590	0.466	1007	0.922	0.735	1589	1.180	0.948	2048
	1170	19.5	0.417	0.322	1042	0.658	0.512	1656	0.856	0.669	2162
	870	14.5	0.321	0.244	1061	0.508	0.389	1691	0.667	0.511	2223
75	1750	23.3	0.485	0.381	1028	0.769	0.603	1629	0.936	0.758	2047
	1170	15.6	0.341	0.261	1056	0.544	0.417	1684	0.658	0.523	2111
	870	11.6	0.261	0.197	1072	0.418	0.315	1712	0.504	0.395	2145
80	1750	21.9	0.476	0.356	1026	0.738	0.559	1611	0.954	0.740	2133
	1170	14.6	0.338	0.246	1061	0.528	0.389	1677	0.682	0.516	2222
	870	10.9	0.261	0.186	1080	0.409	0.295	1712	0.528	0.392	2269
100	1750	17.5	0.393	0.291	1047	0.617	0.458	1650	0.797	0.607	2186
	1170	11.7	0.277	0.200	1076	0.438	0.316	1704	0.565	0.419	2258
	870	8.70	0.213	0.151	1091	0.338	0.239	1733	0.435	0.317	2297
125	1750	14.0	0.311	0.223	1004	0.509	0.361	1627	0.649	0.475	2139
	1170	9.36	0.219	0.153	1029	0.362	0.249	1678	0.460	0.328	2206
	870	6.96	0.168	0.115	1042	0.279	0.188	1704	0.354	0.248	2241
150	1750	11.7	0.293	0.195	1053	0.465	0.309	1669	0.551	0.389	2100
	1170	7.80	0.208	0.134	1081	0.333	0.213	1724	0.391	0.268	2163
	870	5.80	0.161	0.101	1096	0.258	0.161	1752	0.302	0.202	2196
200	1750	8.75	0.240	0.145	1041	0.376	0.228	1640	0.478	0.302	2174
	1170	5.84	0.171	0.099	1069	0.271	0.157	1693	0.343	0.208	2244
	870	4.35	0.133	0.075	1084	0.211	0.119	1721	0.267	0.157	2281
250	1750	7.00	0.188	0.107	964	0.308	0.174	1562	0.385	0.228	2054
	1170	4.68	0.134	0.073	987	0.223	0.120	1610	0.278	0.157	2118
	870	3.48	0.104	0.055	1000	0.174	0.090	1635	0.216	0.119	2151
300	1750	5.83	0.175	0.089	959	0.236	0.129	1394	0.318	0.177	1912
	1170	3.90	0.126	0.061	984	0.170	0.089	1432	0.229	0.122	1969
	870	2.90	0.098	0.046	998	0.132	0.067	1452	0.179	0.092	1999

# Horsepower and Torque Ratings/Double Reduction

## Helical-Worm

Nominal Ratio	SPEED (rpm)		SIZE 1300			SIZE 1325			SIZE 1425			SIZE 1525			SIZE 1600		
	Input	Approx. Output	Horsepower		Output Torque	Horsepower		Output Torque	Horsepower		Output Torque	Horsepower		Output Torque	Horsepower		Output Torque
			Input	Output		Input	Output		Input	Output		Input	Output		Input	Output	
10	1750	175	5.08	4.57	1645	6.99	6.30	2343	11.90	10.80	4036	13.3	12.5	4615	13.3	12.3	4414
	1170	117	4.01	3.55	1911	5.55	4.93	2743	8.91	7.99	4449	8.91	8.06	4450	8.91	8.10	4364
	870	87.0	3.25	2.85	2065	4.53	3.98	2976	6.63	5.88	4402	6.63	5.93	4405	6.63	5.97	4321
15	1750	117	4.56	4.03	2180	5.92	5.26	2839	10.8	9.74	5263	13.3	12.1	6513	13.3	12.1	6541
	1170	78.0	3.49	3.04	2458	4.61	4.03	3256	8.75	7.75	6261	8.91	7.94	6418	8.91	7.98	6450
	870	58.0	2.80	2.41	2615	3.73	3.22	3495	6.63	5.8	6303	6.63	5.84	6342	6.63	5.87	6377
20	1750	87.5	3.97	3.45	2488	5.19	4.56	3287	9.83	8.74	6295	13.3	11.8	8518	13.3	11.9	8569
	1170	58.5	3.01	2.57	2769	3.95	3.41	3678	7.75	6.78	7302	8.91	7.76	8364	8.91	7.82	8422
	870	43.5	2.40	2.02	2927	3.16	2.69	3897	6.31	5.44	7884	6.63	5.69	8242	6.63	5.73	8304
25	1750	70.0	2.75	2.40	2157	3.83	3.35	3117	6.11	5.39	5017	6.11	5.44	5022	6.11	5.48	4929
	1170	46.8	1.98	1.70	2290	2.77	2.39	3320	4.08	3.55	4938	4.08	3.58	4945	4.08	3.60	4855
	870	34.8	1.54	1.30	2362	2.15	1.83	3430	3.04	2.61	4881	3.04	2.63	4888	3.04	2.65	4799
30	1750	58.3	2.93	2.56	2771	3.85	3.41	3680	7.71	6.76	7308	11.2	9.54	10303	13.3	11.5	12393
	1170	39.0	2.15	1.84	2976	2.83	2.45	3966	5.79	4.99	8068	8.91	7.42	11990	8.91	7.49	12101
	870	29.0	1.68	1.42	3088	2.21	1.90	4122	4.59	3.91	8491	6.63	5.41	11751	6.63	5.46	11867
40	1750	43.8	2.39	2.03	2924	3.14	2.70	3894	6.31	5.47	7874	8.91	7.32	10549	10.8	8.98	12932
	1170	29.2	1.72	1.43	3085	2.26	1.91	4118	4.62	3.94	8480	7.59	6.05	13033	8.91	7.19	15481
	870	21.8	1.33	1.09	3171	1.75	1.46	4240	3.62	3.04	8812	6.46	5.01	14539	6.63	5.21	15108
45	1750	38.9	2.23	1.87	3026	2.97	2.50	4044	5.66	4.75	7691	9.42	7.88	12770	10.8	9.13	14810
	1170	26.0	1.63	1.33	3234	2.19	1.80	4365	4.28	3.50	8495	7.24	5.89	14276	7.24	5.95	14420
	870	19.3	1.28	1.03	3347	1.73	1.39	4541	3.41	2.74	8944	5.38	4.29	13977	5.38	4.33	14123
50	1750	35.0	2.00	1.68	3020	2.64	2.24	4028	5.34	4.57	8234	7.44	5.90	10621	9.01	7.23	13027
	1170	23.4	1.42	1.17	3152	1.88	1.56	4213	3.85	3.24	8738	6.38	4.87	13110	7.93	6.14	16527
	870	17.4	1.10	0.89	3223	1.45	1.19	4312	2.99	2.49	9010	5.45	4.04	14618	6.63	4.98	18050
60	1750	29.2	1.82	1.47	3181	2.44	1.98	4284	4.66	3.84	8290	7.39	6.06	13086	9.4	7.61	16447
	1170	19.5	1.31	1.03	3344	1.77	1.40	4536	3.44	2.76	8932	4.94	3.94	12718	7.24	5.67	18323
	870	14.5	1.02	0.79	3432	1.38	1.08	4673	2.71	2.14	9284	3.67	2.86	12452	5.38	4.11	17859
75	1750	23.3	1.520	1.210	3279	2.06	1.640	4434	3.95	3.21	8672	6.11	4.92	13302	7.88	6.13	16549
	1170	15.6	1.090	0.845	3412	1.47	1.150	4642	2.88	2.28	9205	4.08	3.20	12925	6.43	4.8	19394
	870	11.6	0.838	0.641	3483	1.14	0.875	4754	2.25	1.75	9494	3.04	2.33	12656	5.35	3.88	21053
80	1750	21.9	1.430	1.100	3186	1.89	1.470	4247	3.77	2.99	8613	6.45	5.04	14512	7.39	5.84	16825
	1170	14.6	1.040	0.778	3351	1.37	1.040	4477	2.78	2.14	9237	4.94	3.72	16028	4.94	3.77	16251
	870	10.9	0.808	0.594	3440	1.07	0.794	4601	2.19	1.65	9577	3.67	2.69	15615	3.67	2.73	15835
100	1750	17.5	1.210	0.912	3284	1.590	1.220	4385	3.20	2.49	8985	5.62	4.30	15468	6.85	5.18	18653
	1170	11.7	0.864	0.635	3420	1.140	0.849	4574	2.33	1.76	9501	4.08	3.01	16227	4.94	3.58	19295
	870	8.70	0.669	0.482	3492	0.882	0.645	4675	1.82	1.35	9780	3.04	2.18	15815	3.67	2.58	18719
125	1750	14.0	1.030	0.746	3359	1.300	0.958	4312	2.61	1.96	8833	4.76	3.45	15548	6.03	4.45	20042
	1170	9.36	0.740	0.519	3493	0.933	0.667	4488	1.90	1.38	9312	3.61	2.51	16914	4.08	2.89	19474
	870	6.96	0.574	0.394	3564	0.724	0.506	4582	1.49	1.06	9570	2.89	1.95	17667	3.04	2.09	18898
150	1750	11.7	0.903	0.622	3362	1.230	0.842	4547	2.35	1.650	8902	4.17	2.88	15564	5.26	3.70	19988
	1170	7.80	0.651	0.433	3495	0.895	0.589	4755	1.73	1.170	9436	3.18	2.10	16928	4.05	2.72	21989
	870	5.80	0.506	0.328	3566	0.700	0.448	4867	1.36	0.895	9724	2.55	1.63	17680	3.04	1.97	21404
200	1750	8.75	0.728	0.453	3266	0.951	0.606	4361	1.90	1.240	8941	3.39	2.14	15389	4.27	2.76	19841
	1170	5.84	0.530	0.315	3398	0.692	0.422	4546	1.40	0.877	9447	2.61	1.55	16734	3.32	2.03	21812
	870	4.35	0.415	0.239	3469	0.542	0.321	4644	1.11	0.671	9720	2.11	1.21	17475	2.7	1.58	22907
250	1750	7.00	0.619	0.358	3226	0.772	0.460	4141	1.530	0.943	8487	2.86	1.660	14934	3.59	2.14	19255
	1170	4.68	0.452	0.249	3352	0.563	0.320	4308	1.140	0.664	8942	2.22	1.210	16238	2.82	1.57	21166
	870	3.48	0.355	0.189	3420	0.442	0.243	4398	0.899	0.507	9187	1.80	0.936	16956	2.30	1.23	22227
300	1750	5.83	0.529	0.283	3062	0.639	0.358	3868	1.260	0.733	7923	2.44	1.31	14176	3.06	1.690	18209
	1170	3.90	0.388	0.197	3182	0.468	0.249	4019	0.938	0.516	8331	1.91	0.955	15440	2.42	1.240	20024
	870	2.90	0.306	0.149	3246	0.367	0.189	4100	0.743	0.393	8550	1.56	0.741	16094	1.99	0.968	21032

# Horsepower and Torque Ratings/Double Reduction

## Helical-Worm

Nominal Ratio	SPEED (rpm)		SIZE 1700			SIZE 1800			SIZE 11000		
	Input	Approx. Output	Horsepower		Output Torque (lb-in)	Horsepower		Output Torque (lb-in)	Horsepower		Output Torque (lb-in)
			Input	Output		Input	Output		Input	Output	
25	1750	70.0	19.6	18.1	17000	31.9	29.7	26900	42.1	39.3	36800
	1170	46.8	14.5	13.3	18600	23.6	21.7	29500	31.1	28.7	40200
	870	34.8	11.6	10.5	19800	18.9	17.3	31500	24.9	22.7	42800
37.5	1750	18.6	18.6	16.9	22900	26.8	24.6	32300	42.1	39	52300
	1170	13.7	13.7	12.3	25000	20.0	18.1	35600	31.1	28.5	57000
	870	10.7	10.7	9.56	26000	15.7	14.1	37200	24.9	22.6	60900
50	1750	35.0	15.2	13.7	24400	21.7	19.7	34100	37.8	34.6	61700
	1170	23.4	11.0	9.73	26000	16.1	14.4	37300	28.4	25.7	68400
	870	17.4	8.50	7.44	26700	12.6	11.2	38800	22.6	20.2	72500
75	1750	23.3	11.2	9.74	26200	16.2	14.3	37100	28.4	25.2	67700
	1170	15.6	8.20	7.00	28100	11.8	10.2	39700	21.3	18.6	74600
	870	11.6	6.41	5.40	29200	9.30	7.94	41500	16.9	14.6	78600
100	1750	17.5	8.95	7.41	27800	12.6	10.6	38600	22.3	19.0	71400
	1170	11.7	6.55	5.31	29800	9.30	7.67	41700	16.9	14.1	79100
	870	8.70	5.14	4.10	31000	7.30	5.93	43300	13.5	11.1	83500
125	1750	14.0	7.56	6.14	27500	10.8	8.90	38600	18.9	15.8	70600
	1170	9.36	5.51	4.34	29100	8.00	6.43	41800	14.2	12.4	83100
	870	6.96	4.31	3.33	30000	6.29	4.96	43300	11.3	9.03	81300
138	1750	12.7	6.90	5.84	29000	10.2	8.75	41200	17.8	15.4	79000
	1170	8.4	4.90	4.07	30000	7.22	6.09	42800	12.8	10.9	83500
	870	6.3	3.69	3.08	30800	5.54	4.67	44200	9.73	8.25	85100
150	1750	11.7	6.26	4.95	26700	9.05	7.27	38000	15.8	13.0	69000
	1170	7.80	4.56	3.52	28400	6.70	5.23	40900	11.7	9.35	75400
	870	5.80	3.57	2.70	29300	5.24	4.00	42100	9.26	7.26	78800
185	1750	9.46	5.52	4.43	30800	8.00	6.53	42900	14.2	11.7	83900
	1170	6.3	3.92	3.08	32000	5.71	4.56	44800	10.2	8.22	88100
	870	4.7	2.98	2.35	32800	4.42	3.51	46400	7.83	6.27	90400
200	1750	8.75	5.06	3.70	27100	7.00	5.22	37000	12.4	9.46	69200
	1170	5.84	3.70	2.62	28700	5.35	3.85	40800	9.41	6.93	75700
	870	4.35	2.91	2.01	29600	4.22	2.96	42200	7.54	5.41	79500
210	1750	8.33	4.9	4.07	30200	6.94	5.84	43200	12.6	10.7	80800
	1170	5.57	3.34	2.78	30800	4.77	3.99	44200	8.63	7.28	83200
	870	4.14	2.51	2.06	30700	3.59	2.97	44200	6.50	5.42	83200
250	1750	7.00	3.77	3.25	28500	5.35	4.63	41100	10.1	8.81	77300
	1170	4.68	2.55	2.17	23500	3.62	3.09	41000	6.82	5.87	77000
	870	3.48	1.92	1.62	28500	2.72	2.30	41000	5.12	4.36	77000
280	1750	6.25	3.98	3.09	32000	5.50	4.38	45300	10.1	8.13	86800
	1170	4.17	2.70	2.11	32800	3.81	3.00	46400	6.95	5.53	88400
	870	3.10	2.04	1.59	32800	2.88	2.23	46400	5.25	4.11	83300
300	1750	5.83	3.31	2.23	24500	4.78	3.23	34300	8.15	5.69	62400
	1170	3.90	2.44	1.58	25900	3.58	2.32	36800	6.19	4.12	67600
	870	2.90	1.93	1.21	26700	2.83	1.78	38000	4.96	3.19	70500

# Double Reduction/Helical-Worm/Basic Drive (Larger Sizes on Page 90)

Dimensions— Inches

Type  
**WBHM**

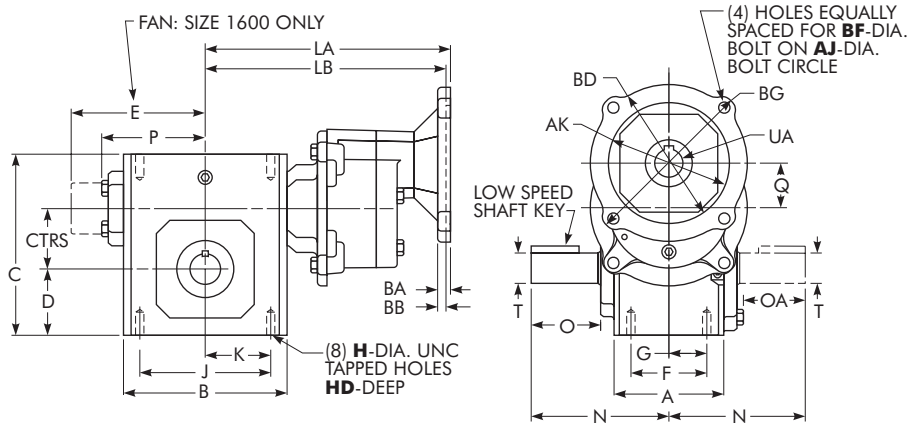

Type  
**WBH**

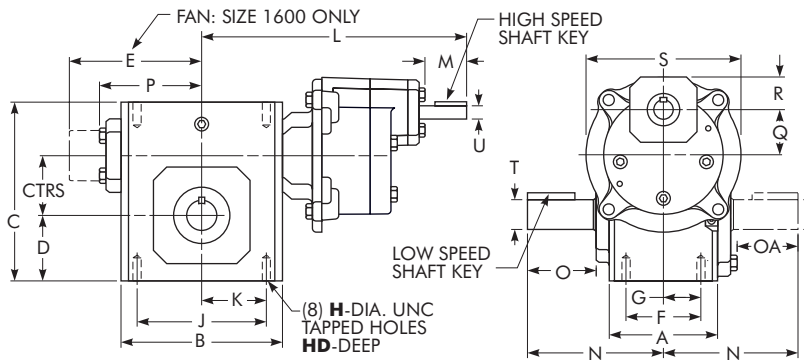

SEE PAGE 89 FOR MOTOR MOUNTING DIMENSIONS.

(Continued on next page)

DRIVE SIZE ★	CTRS	A	B	C	D	E	F	G	H	HD	J	K	L	M•	N	O♦	OA♦	P	Q	R	S
1133	1.33	2.82	3.80	4.66	1.72	...	2.00	1.00	.3125-18	.50	3.25	1.63	9.02	1.58	4.00	2.16	1.94	2.61	1.68	1.37	4.52
1154	1.54	3.44	4.88	5.38	1.91	...	2.75	1.38	.3125-18	.63	4.19	2.09	9.55	1.58	4.31	2.11	1.90	3.14	1.68	1.37	4.52
1175	1.75	3.56	5.06	5.75	2.06	...	2.75	1.38	.3125-18	.63	4.19	2.09	9.65	1.58	4.31	2.05	1.84	3.24	1.68	1.37	4.52
1206	2.06	3.81	5.80	6.38	2.28	...	3.00	1.50	.3125-18	.63	4.75	2.38	10.02	1.58	4.68	2.29	2.08	3.61	1.68	1.37	4.52
1238	2.38	4.06	6.12	6.94	2.50	...	2.88	1.44	.3750-16	.56	5.00	2.50	9.88	1.48	5.14	2.66	2.44	3.77	2.88	2.73	6.74
1262	2.63	4.84	7.12	8.00	2.94	...	3.38	1.69	.3750-16	.69	6.38	3.19	10.44	1.48	5.63	2.73	2.52	4.34	2.88	2.73	6.74
1300	3.00	5.25	8.12	8.88	3.25	...	4.00	2.00	.4375-14	.88	7.00	3.50	10.94	1.48	6.75	3.60	3.36	4.84	2.88	2.73	6.74
1325	3.25	5.75	8.50	9.38	3.50	...	4.00	2.00	.4375-14	.88	7.50	3.75	11.13	1.48	7.06	3.66	3.42	5.02	2.88	2.73	6.74
1425	4.25	6.13	10.25	11.38	4.44	...	5.00	2.50	.6250-11	1.00	8.50	4.25	14.97	1.96	8.12	4.50	4.21	6.10	2.88	1.75	8.50
1525	5.25	7.19	13.00	14.00	5.12	...	5.81	2.91	.6250-11	1.25	11.00	5.50	16.37	1.96	9.06	4.78	4.53	7.50	2.88	1.75	8.50
1600	6.00	8.13	14.25	16.50	6.50	10.24	6.38	3.19	.6250-11	1.00	12.75	6.38	17.09	1.96	10.00	4.65	4.65	...	2.88	1.75	8.50

(See Page 5 for footnotes.)



# Assemblies \*

Reverse all arrows for opposite rotation of high speed shaft.

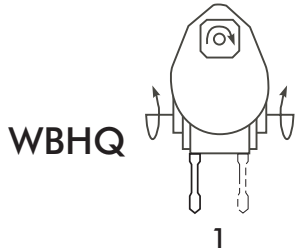
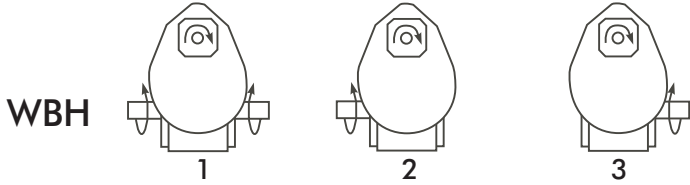
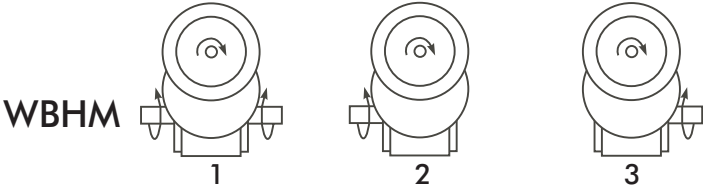

(See Page 5 for footnotes.)



# Motor Data

## NEMA Motor Flange Face Locations — Inches

DRIVE SIZE	56C/140TC	180TC	210TC
	LA	LB	LB
1133	8.12	...	...
1154	8.65	...	...
1175	8.75	...	...
1206	9.12	...	...
1238	9.88	...	...
1262	10.44	...	...
1300	10.94	...	...
1325	11.13	...	...
1425	13.79	14.23	14.23
1525	15.19	15.63	15.63
1600	15.91	16.35	16.35

## NEMA Motor Mounting Dimensions — Inches

FRAME SIZE	AJ	AK	BA	BB	BD	BF	BG	UA	Keyway
56C	5.88	4.50	.50	...	6.50 *	.41	6.50	.625	.1875 x .0938
140TC	5.88	4.50	.50	...	6.50 *	.41	6.50	.875	.1875 x .0938
180TC	7.25	8.50	...	.56	9.00	.53	9.00	1.125	.2500 x .1250
210TC	7.25	8.50	...	.56	9.00	.53	9.00	1.375	.3125 x .1562

(See Page 5 for footnotes.)

# Double & Triple Reduction/Helical-Worm/Basic Drive (Smaller Sizes on Pages 86 & 87)

Type  
**WBH**

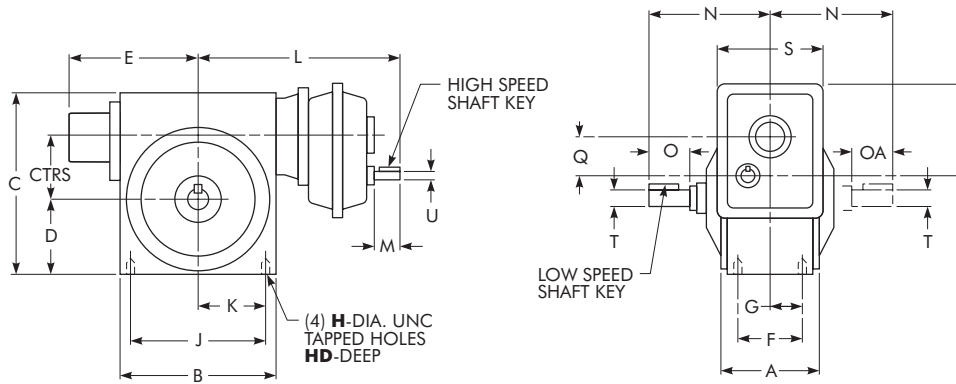

Type  
**WBHQ**

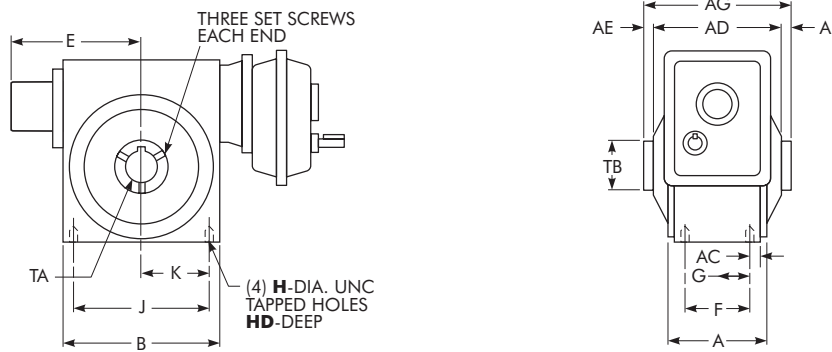

DRIVE SIZE ★	CTRS	A	B	C	D	E	F	G	H	HD	J	K	L	M •	N	O ♦	OA ♦	Q	R	S
<b>1700</b>	7.00	7.63	14.88	18.91	7.59	10.63	5.50	2.75	1.0000-8	1.56	12.50	6.25	19.68	2.50	11.76	5.65	5.65	3.49	8.10	10.36
<b>1800</b>	8.00	8.63	17.00	20.96	8.86	11.93	6.50	3.25	1.0000-8	1.66	14.25	7.13	21.30	3.00	12.25	5.98	5.98	4.07	9.89	11.64
<b>11000</b>	10.00	9.53	20.88	25.47	10.36	14.34	6.88	3.44	1.2500-7	2.04	17.75	8.88	25.78	3.50	14.75	6.76	6.76	4.90	11.83	13.85

DRIVE SIZE ★	Low Speed Shaft		Hollow Low Speed Shaft		High Speed Shaft		AC	AD	AE	AG	AL	Approx. Wt – lb		
	T -.0005 -.0015	Key	TA Max ■ +.002 -.000	TB	Key	U +.0000 -.0005						Key	WBH	WBHQ
<b>1700</b>	2.750	.625 x .625 x 4.00	3.938	4.92	1.000 x .750 x 7.00	1.1250	.250 x .250 x 2.25	1.06	11.36	1.09	13.50	1.09	510	510
<b>1800</b>	3.000	.750 x .750 x 4.50	4.438	5.55	1.000 x .750 x 8.50	1.3750	.313 x .313 x 2.75	1.06	12.48	1.03	14.50	1.03	770	770
<b>11000</b>	3.750	.875 x .875 x 5.00	5.438	6.67	1.250 x .938 x 12.00	1.5000	.375 x .375 x 3.25	1.33	15.78	1.39	18.50	1.39	1250	1250

(See Page 5 for footnotes.)

# Assemblies \*

Reverse all arrows for opposite rotation of high speed shaft.

Double Reduction — Solid Output Shaft

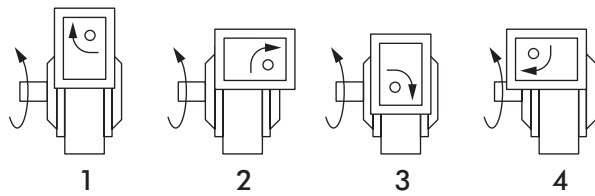

WBH

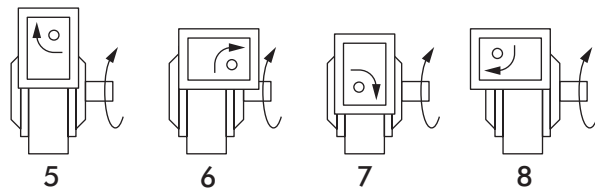

Double Reduction — Double L.S. Shaft Extension

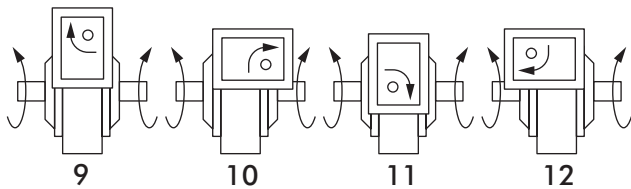

Triple Reduction — Solid Output Shaft

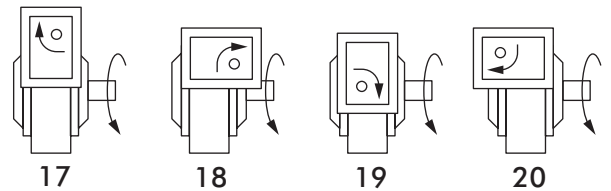
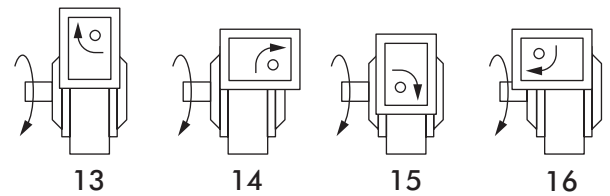

Triple Reduction — Double L.S. Shaft Extension

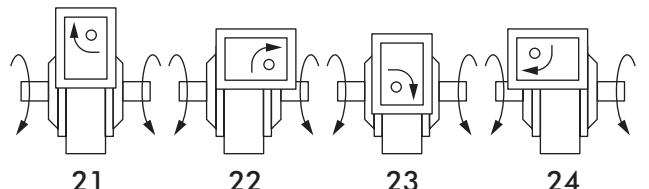

Double Reduction — Hollow Output

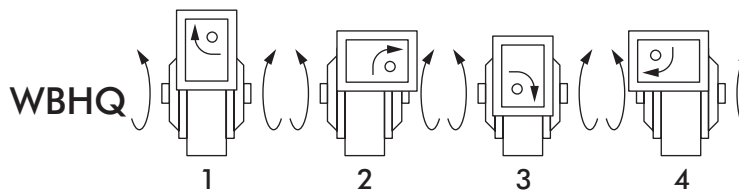

Triple Reduction — Hollow Output

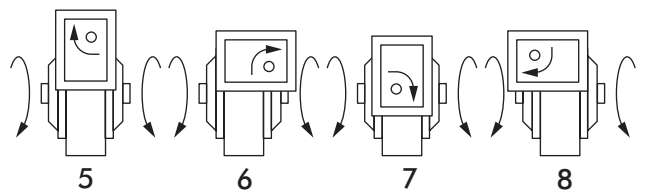

**DOUBLE  
REDUCTION  
RATIOS  
(Nominal)**

- 25:1
- 37.5:1
- 50:1
- 75:1
- 100:1
- 125:1
- 150:1
- 200:1
- 300:1

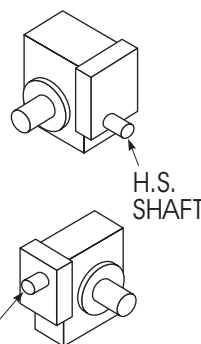

**TRIPLE  
REDUCTION  
RATIOS  
(Nominal)**

- |       |        |
|-------|--------|
| 138:1 | 560:1  |
| 185:1 | 625:1  |
| 210:1 | 700:1  |
| 250:1 | 750:1  |
| 280:1 | 840:1  |
| 350:1 | 1000:1 |
| 375:1 | 1250:1 |
| 420:1 | 1500:1 |
| 500:1 | 1750:1 |

(See Page 5 for footnotes.)

# Double Reduction/Helical-Worm/Worm Over (Larger Sizes on Page 96)

## Dimensions — Inches

Type  
WOHM

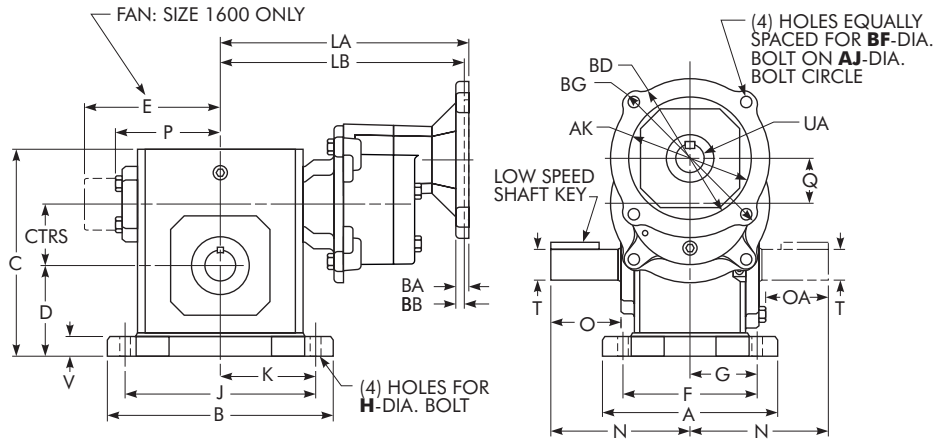

Type  
WOH

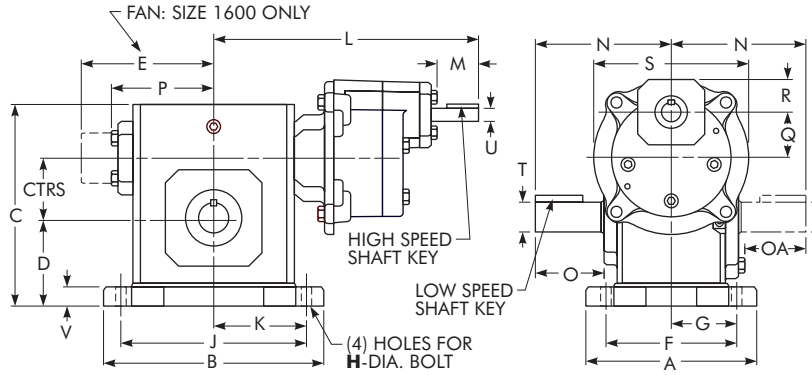

SEE PAGE 95 FOR MOTOR MOUNTING DIMENSIONS.

(Continued on next page)

DRIVE SIZE ★	CTRS	A	B	C	D	E	F	G	H	J	K	L	M•	N	O♦	OA♦	P	Q	R	S
1133	1.33	5.38	5.37	5.19	2.25	...	4.38▲	2.19▲	.34	4.37	2.19	9.02	1.58	4.00	2.16	1.94	2.61	1.68	1.37	4.52
1154	1.54	5.56	6.50	5.97	2.50	...	4.31	2.16	.41	5.25	2.63	9.55	1.58	4.31	2.11	1.90	3.14	1.68	1.37	4.52
1175	1.75	5.75	6.99	6.44	2.75	...	4.50	2.25	.41	5.75	2.88	9.65	1.58	4.31	2.05	1.84	3.24	1.68	1.37	4.52
1206	2.06	6.00	7.69	7.09	3.00	...	4.69	2.34	.47	6.38	3.19	10.02	1.58	4.68	2.29	2.08	3.61	1.68	1.37	4.52
1238	2.38	6.19	8.37	7.69	3.25	...	4.88	2.44	.47	7.06	3.53	9.88	1.48	5.14	2.66	2.44	3.77	2.88	2.73	6.74
1262	2.63	6.50	9.25	8.75	3.69	...	5.25	2.63	.53	8.00	4.00	10.44	1.48	5.63	2.73	2.52	4.34	2.88	2.73	6.74
1300	3.00	7.50	10.00	9.63	4.00	...	5.88	2.94	.53	8.44	4.22	10.94	1.48	6.75	3.60	3.36	4.84	2.88	2.73	6.74
1325	3.25	7.75	11.12	10.25	4.38	...	6.13	3.06	.53	9.50	4.75	11.13	1.48	7.06	3.66	3.42	5.02	2.88	2.73	6.74
1425	4.25	9.75	13.24	12.38	5.44	...	7.63	3.81	.66	11.12	5.56	14.97	1.96	8.12	4.50	4.21	6.10	2.88	1.75	8.50
1525	5.25	10.50	16.24	15.13	6.25	...	8.38	4.19	.78	14.12	7.06	16.37	1.96	9.06	4.78	4.53	7.50	2.88	1.75	8.50
1600	6.00	12.00	18.99	17.75	7.75	10.24	9.50	4.75	.91	16.49	8.25	17.09	1.96	10.00	4.66	4.66	...	2.88	1.75	8.50

(See Page 5 for footnotes.)

Type  
**WOHQM**

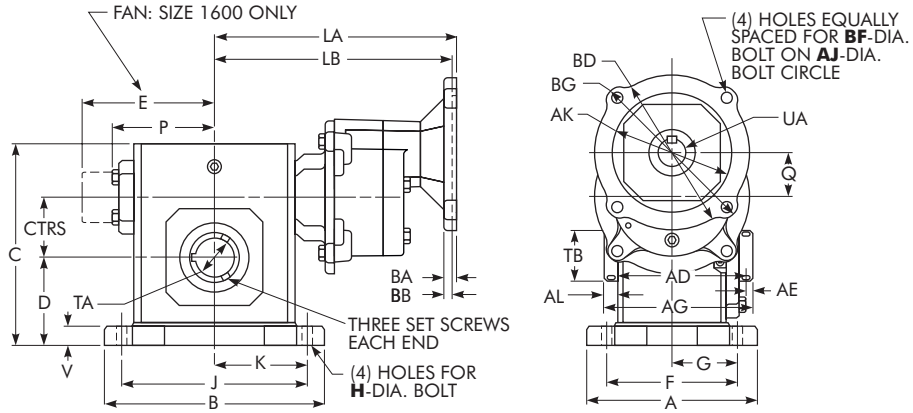

Type  
**WOHQ**

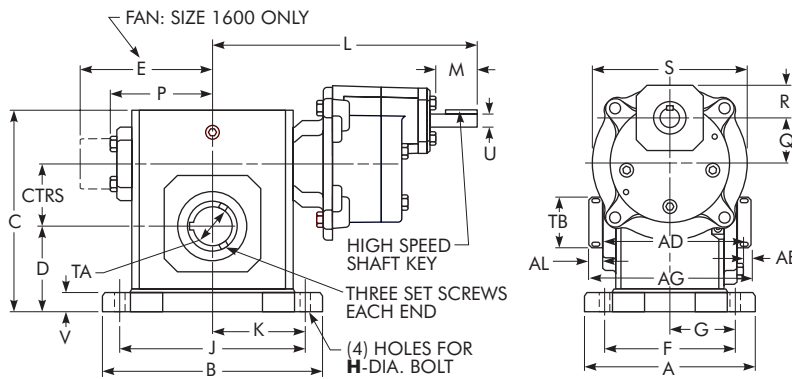

SEE PAGE 95 FOR MOTOR MOUNTING DIMENSIONS.

(Continued from preceding page)

DRIVE SIZE ★	Low Speed Shaft		Hollow Low Speed Shaft		High Speed Shaft		V	AD	AE	AG	AL	Approx				
	T -.0005 -.0015	Key	TA Max ■ +.002 -.000	TB	Key	U -.0005 -.0015						Key	WOHM	WOH	WOHQM	WOHQ
<b>1133</b>	.6250	.188 x .188 x 1.50	.625	1.00	.188 x .188 x 1.50	.5000	.125 x .125 x 1.25	.53	3.90	.32	4.75	.53	37	37	37	41
<b>1154</b>	.7500	.188 x .188 x 1.50	.625	1.00	.188 x .188 x 1.50	.5000	.125 x .125 x 1.25	.59	4.61	.30	5.42	.51	42	42	42	44
<b>1175</b>	.8750	.188 x .188 x 1.38	1.000	1.44	.250 x .250 x 2.50	.5000	.125 x .125 x 1.25	.69	4.73	.28	5.50	.49	44	45	45	46
<b>1206</b>	1.0000	.250 x .250 x 1.44	1.438	1.94	.375 x .313 x 3.00	.5000	.125 x .125 x 1.25	.72	4.99	.40	6.00	.61	51	54	54	53
<b>1238</b>	1.1250	.250 x .250 x 1.75	1.438	1.94	.375 x .313 x 3.00	.6250	.188 x .188 x 1.25	.75	5.18	.31	6.00	.51	77	78	78	79
<b>1262</b>	1.1250	.250 x .250 x 1.44	1.438	1.94	.375 x .313 x 3.00	.6250	.188 x .188 x 1.25	.75	6.01	.39	7.00	.60	92	90	90	94
<b>1300</b>	1.2500	.250 x .250 x 2.25	1.938	2.51	.500 x .375 x 3.00	.6250	.188 x .188 x 1.25	.75	6.53	.36	7.50	.60	119	119	119	121
<b>1325</b>	1.3750	.313 x .313 x 2.50	1.938	2.51	.500 x .375 x 3.00	.6250	.188 x .188 x 1.25	.88	7.04	.29	7.88	.54	122	122	122	124
<b>1425</b>	1.8750	.500 x .500 x 3.06	2.188	2.75	.500 x .375 x 3.00	.8750	.188 x .188 x 1.50	1.00	7.53	.34	8.50	.63	190	190	190	194
<b>1525</b>	2.0000	.500 x .500 x 3.50	3.438	4.26	.875 x .688 x 4.00	.8750	.188 x .188 x 1.50	1.13	8.85	.68	10.50	.97	303	303	303	307
<b>1600</b>	2.2500	.500 x .500 x 4.00	3.438	4.18	.875 x .688 x 4.00	.8750	.188 x .188 x 1.50	1.25	10.52	.52	11.50	.52	398	398	398	402

# Assemblies \*

Reverse all arrows for opposite rotation of high speed shaft.

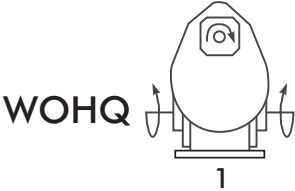
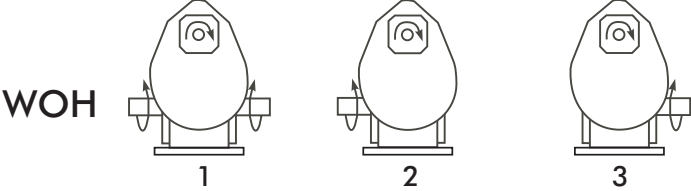
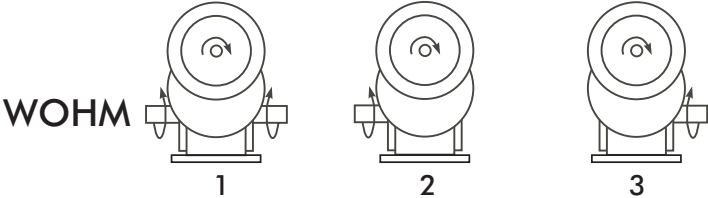

(See Page 5 for footnotes.)

# Motor Data

## NEMA Motor Flange Face Locations — Inches

DRIVE SIZE	56C/140TC	180TC	210TC
	LA	LB	LB
1133	8.12	...	...
1154	8.65	...	...
1175	8.75	...	...
1206	9.12	...	...
1238	9.88	...	...
1262	10.44	...	...
1300	10.94	...	...
1325	11.13	...	...
1425	13.79	14.23	14.23
1525	15.19	15.63	15.63
1600	15.91	16.35	16.35

## NEMA Motor Mounting Dimensions — Inches

FRAME SIZE	AJ	AK	BA	BB	BD	BF	BG	UA	Keyway
56C	5.88	4.50	.50	...	6.50 <sup>♣</sup>	.41	6.50	.625	.1875 x .0938
140TC	5.88	4.50	.50	...	6.50 <sup>♣</sup>	.41	6.50	.875	.1875 x .0938
180TC	7.25	8.50	...	.56	9.00	.53	9.00	1.125	.2500 x .1250
210TC	7.25	8.50	...	.56	9.00	.53	9.00	1.375	.3125 x .1562

(See Page 5 for footnotes.)

# Double & Triple Reduction/Helical-Worm/Worm Over (Smaller Sizes on Pages

92 & 93)

Type  
WOH

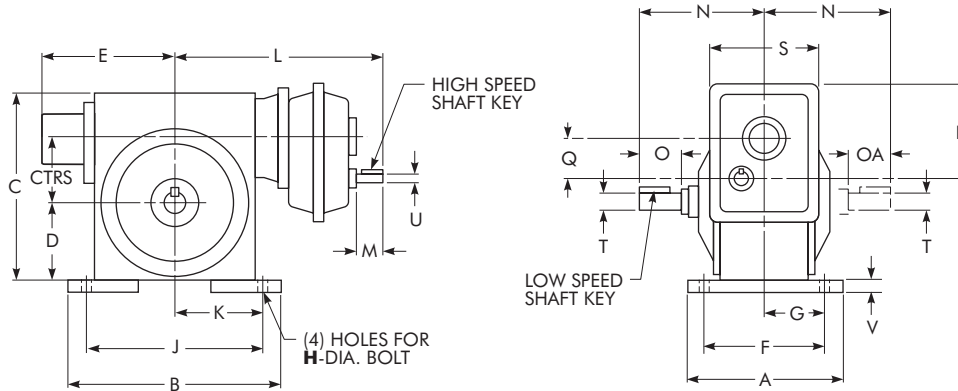

Type  
WOHQ

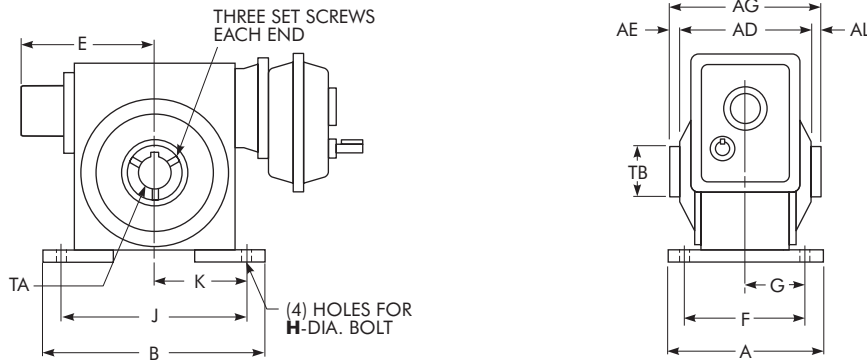

DRIVE SIZE ★	CTRS	A	B	C	D	E	F	G	H	J	K	L	M •	N	O ♦	OA ♦	Q	R	S
1700	7.00	13.38	15.38	20.33	9.00	10.63	11.25	5.63	1.13	13.00	6.50	19.68	2.50	11.76	5.69	5.69	3.49	8.10	10.36
1800	8.00	13.50	17.37	22.61	10.50	11.93	11.50	5.75	1.13	14.75	7.38	21.30	3.00	12.25	6.02	6.02	4.07	9.89	11.64
11000	10.00	16.88	21.24	27.12	12.00	14.34	14.00	7.00	1.44	17.00	8.50	25.78	3.50	14.75	6.80	6.80	4.90	11.83	13.85

DRIVE SIZE ★	Low Speed Shaft		Hollow Low Speed Shaft		High Speed Shaft		V	AD	AE	AG	AL	Approx. Wt - lb		
	T -.0005 -.0015	Key	TA Max ■ +.002 -.000	TB	Key	U +.0000 -.0005						Key	WOH	WOHQ
1700	2.7500	.625 x .625 x 4.00	3.938	4.92	1.000 x .750 x 7.00	1.1250	.250 x .250 x 2.25	1.42	11.36	1.09	13.50	1.09	510	510
1800	3.0000	.750 x .750 x 4.50	4.438	5.55	1.000 x .750 x 8.50	1.3750	.313 x .313 x 2.75	1.65	12.48	1.03	14.50	1.03	770	770
11000	3.7500	.875 x .875 x 5.00	5.438	6.67	1.250 x .938 x 12.00	1.5000	.375 x .375 x 3.25	1.65	15.78	1.39	18.50	1.39	1250	1250

(See Page 5 for footnotes.)



# Assemblies \*

Reverse all arrows for opposite rotation of high speed shaft.

Double Reduction — Solid Output Shaft

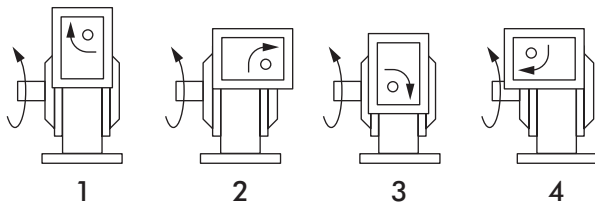

WOH

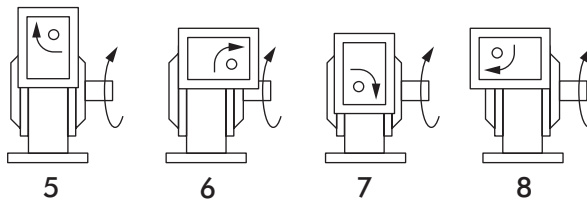

Double Reduction — Double L.S. Shaft Extension

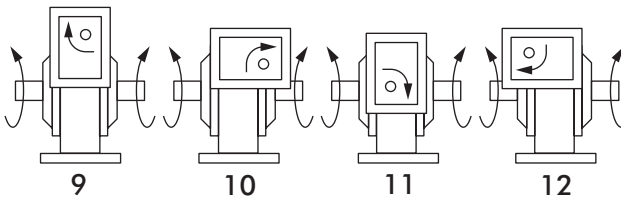

Triple Reduction — Solid Output Shaft

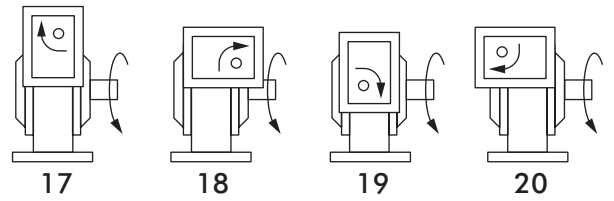
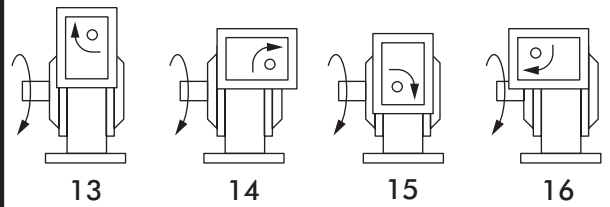

Triple Reduction — Double L.S. Shaft Extension

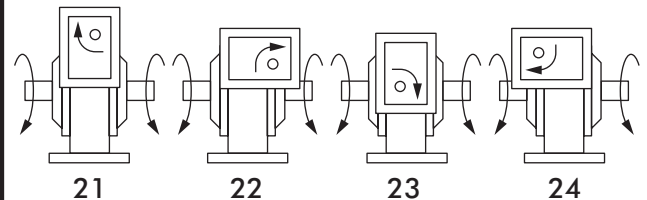

Double Reduction — Hollow Output

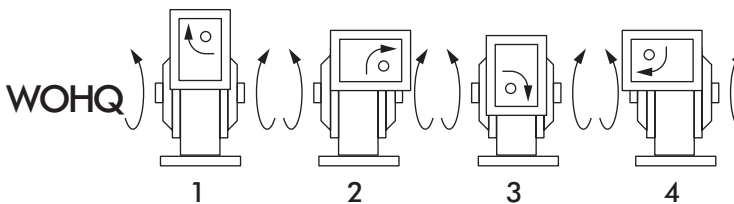

WOHQ

Triple Reduction — Hollow Output

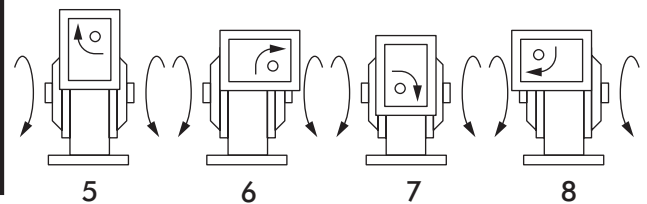

**DOUBLE  
REDUCTION  
RATIOS  
(Nominal)**

- 25:1
- 37.5:1
- 50:1
- 75:1
- 100:1
- 125:1
- 150:1
- 200:1
- 300:1

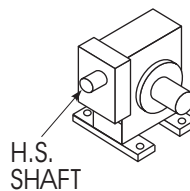
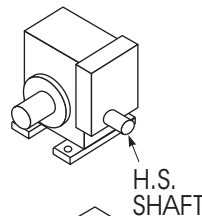

**TRIPLE  
REDUCTION  
RATIOS  
(Nominal)**

- |       |        |
|-------|--------|
| 138:1 | 560:1  |
| 185:1 | 625:1  |
| 210:1 | 700:1  |
| 250:1 | 750:1  |
| 280:1 | 840:1  |
| 350:1 | 1000:1 |
| 375:1 | 1250:1 |
| 420:1 | 1500:1 |
| 500:1 | 1750:1 |

(See Page 5 for footnotes.)

# Double Reduction/Helical-Worm/Worm Under (Larger Sizes on Page 102)

## Dimensions — Inches

Type  
**WUHM**

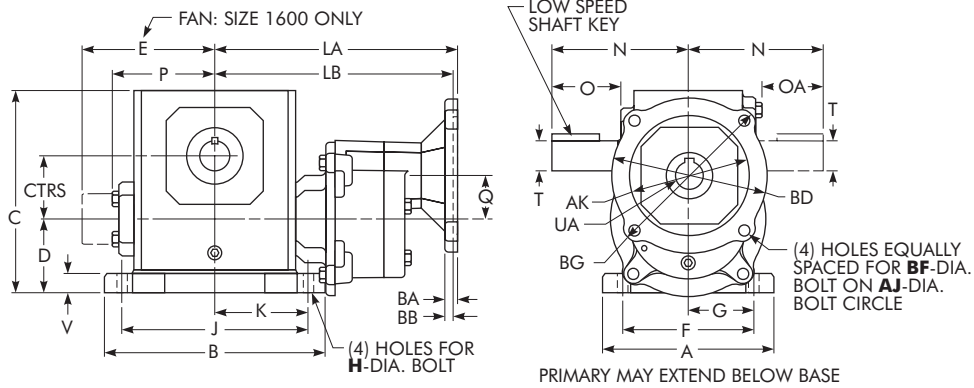

Type  
**WUH**

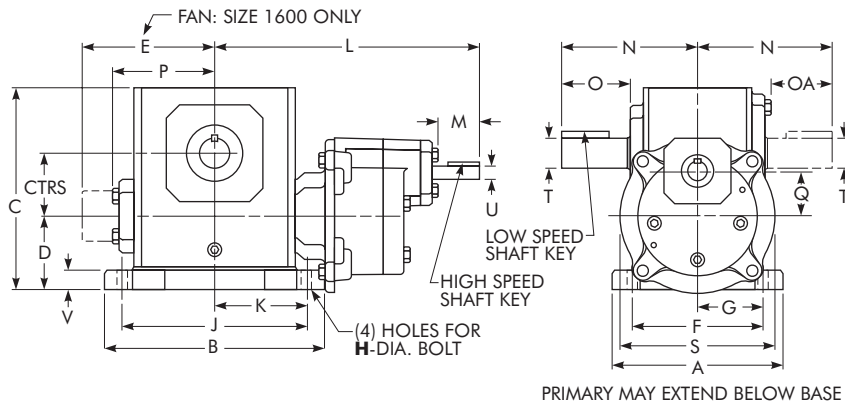

SEE PAGE 101 FOR MOTOR MOUNTING DIMENSIONS.

(Continued on next page)

DRIVE SIZE ★	CTRS	A	B	C	D	E	F	G	H	J	K	L	M •	N	O †	OA †	P	Q	S
<b>1133</b>	1.33	5.38	5.37	5.19	2.14	...	4.38 ▲	2.19 ▲	.34	4.37	2.19	9.02	1.58	4.00	2.16	1.94	2.61	1.68	4.52
<b>1154</b>	1.54	5.56	6.50	5.97	2.52	...	4.31	2.16	.41	5.25	2.63	9.55	1.58	4.31	2.11	1.90	3.14	1.68	4.52
<b>1175</b>	1.75	5.75	6.99	6.44	2.63	...	4.50	2.25	.41	5.75	2.88	9.65	1.58	4.31	2.05	1.84	3.24	1.68	4.52
<b>1206</b>	2.06	6.00	7.69	7.09	2.75	...	4.69	2.34	.47	6.38	3.19	10.02	1.58	4.68	2.29	2.08	3.61	1.68	4.52
<b>1238</b>	2.38	6.19	8.37	7.69	2.81	...	4.88	2.44	.47	7.06	3.53	9.88	1.48	5.14	2.66	2.44	3.77	2.88	6.74
<b>1262</b>	2.63	6.50	9.25	8.75	3.19	...	5.25	2.63	.53	8.00	4.00	10.44	1.48	5.63	2.73	2.52	4.34	2.88	6.74
<b>1300</b>	3.00	7.50	10.00	9.63	3.38	...	5.88	2.94	.53	8.44	4.22	10.94	1.48	6.75	3.60	3.36	4.84	2.88	6.74
<b>1325</b>	3.25	7.75	11.12	10.25	3.50	...	6.13	3.06	.53	9.50	4.75	11.13	1.48	7.06	3.66	3.42	5.02	2.88	6.74
<b>1425</b>	4.25	9.75	13.24	12.38	3.69	...	7.63	3.81	.66	11.12	5.56	14.97	1.96	8.12	4.50	4.21	6.10	2.88	8.50
<b>1525</b>	5.25	10.50	16.24	15.13	4.76	...	8.38	4.19	.78	14.12	7.06	16.37	1.96	9.06	4.78	4.53	7.50	2.88	8.50
<b>1600</b>	6.00	12.00	18.99	17.75	5.25	10.24	9.50	4.75	.91	16.49	8.25	17.09	1.96	10.00	4.66	4.66	...	2.88	8.50

(See Page 5 for footnotes.)

Type  
**WUHQM**

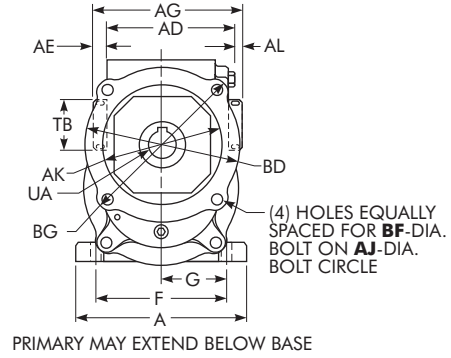
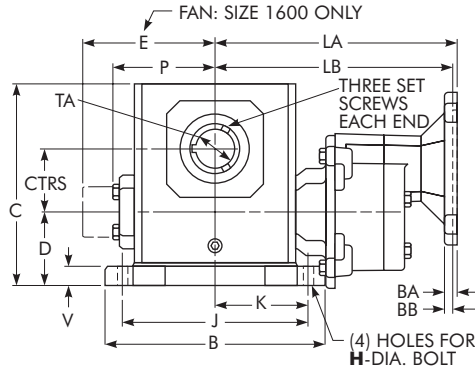

Type  
**WUHQ**

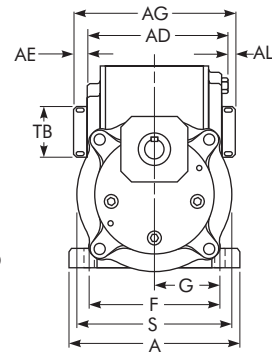
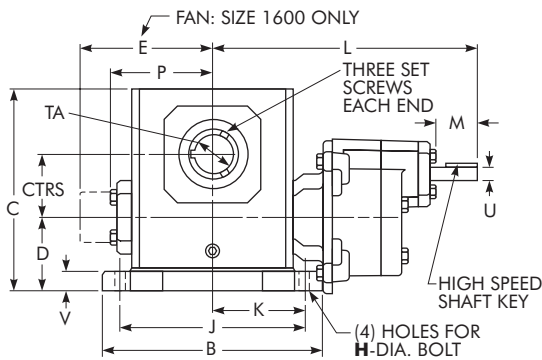

(Continued from preceding page)

DRIVE SIZE ★	Low Speed Shaft		Hollow Low Speed Shaft		High Speed Shaft		V	AD	AE	AG	AL	Approx. Wt - lb				
	T -.0005 -.0015	Key	TA Max ■ +.002 -.000	TB	Key	U -.0005 -.0015						Key	WUHM	WUH	WUHQM	WUHQ
<b>1133</b>	.6250	.188 x .188 x 1.50	.625	1.00	.188 x .188 x 1.50	.5000	.125 x .125 x 1.25	.53	3.90	.32	4.75	.53	41	37	37	37
<b>1154</b>	.7500	.188 x .188 x 1.50	.625	1.00	.188 x .188 x 1.50	.5000	.125 x .125 x 1.25	.59	4.61	.30	5.42	.51	44	42	42	42
<b>1175</b>	.8750	.188 x .188 x 1.38	1.000	1.44	.250 x .250 x 2.50	.5000	.125 x .125 x 1.25	.69	4.73	.28	5.50	.49	46	44	45	45
<b>1206</b>	1.0000	.250 x .250 x 1.44	1.438	1.94	.375 x .313 x 3.00	.5000	.125 x .125 x 1.25	.72	4.99	.40	6.00	.61	53	51	54	54
<b>1238</b>	1.1250	.250 x .250 x 1.75	1.438	1.94	.375 x .313 x 3.00	.6250	.188 x .188 x 1.25	.75	5.18	.31	6.00	.51	79	77	78	78
<b>1262</b>	1.1250	.250 x .250 x 1.44	1.438	1.94	.375 x .313 x 3.00	.6250	.188 x .188 x 1.25	.75	6.01	.39	7.00	.60	94	92	90	90
<b>1300</b>	1.2500	.250 x .250 x 2.25	1.938	2.51	.500 x .375 x 3.00	.6250	.188 x .188 x 1.25	.75	6.53	.36	7.50	.60	121	119	119	119
<b>1325</b>	1.3750	.313 x .313 x 2.50	1.938	2.51	.500 x .375 x 3.00	.6250	.188 x .188 x 1.25	.88	7.04	.29	7.88	.54	124	122	122	122
<b>1425</b>	1.8750	.500 x .500 x 3.06	2.188	2.75	.500 x .375 x 3.00	.8750	.188 x .188 x 1.50	1.00	7.53	.34	8.50	.63	194	190	190	190
<b>1525</b>	2.0000	.500 x .500 x 3.50	3.438	4.26	.875 x .688 x 4.00	.8750	.188 x .188 x 1.50	1.13	8.85	.68	10.50	.97	307	303	303	303
<b>1600</b>	2.2500	.500 x .500 x 4.00	3.438	4.18	.875 x .688 x 4.00	.8750	.188 x .188 x 1.50	1.25	10.52	.52	11.50	.52	402	398	398	398

# Assemblies \*

Reverse all arrows for opposite rotation of high speed shaft.

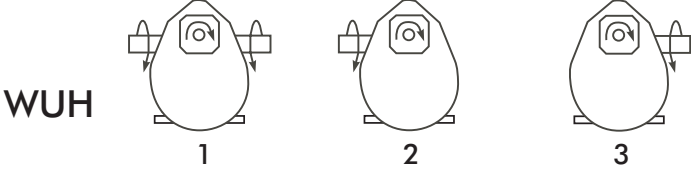
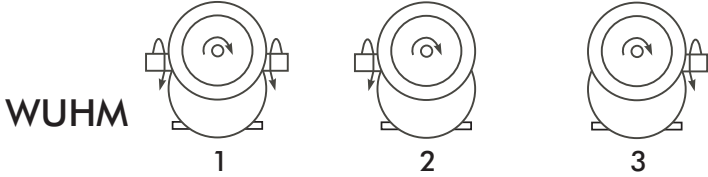

(See Page 5 for footnotes.)

# Motor Data

## NEMA Motor Flange Face Locations — Inches

DRIVE SIZE	56C/140TC	180TC	210TC
	LA	LB	LB
1133	8.12	...	...
1154	8.65	...	...
1175	8.75	...	...
1206	9.12	...	...
1238	9.88	...	...
1262	10.44	...	...
1300	10.94	...	...
1325	11.13	...	...
1425	13.79	14.23	14.23
1525	15.19	15.63	15.63
1600	15.91	16.35	16.35

## NEMA Motor Mounting Dimensions — Inches

FRAME SIZE	AJ	AK	BA	BB	BD	BF	BG	UA	Keyway
56C	5.88	4.50	.50	...	6.50 *	.41	6.50	.625	.1875 x .0938
140TC	5.88	4.50	.50	...	6.50 *	.41	6.50	.875	.1875 x .0938
180TC	7.25	8.50	...	.56	9.00	.53	9.00	1.125	.2500 x .1250
210TC	7.25	8.50	...	.56	9.00	.53	9.00	1.375	.3125 x .1562

(See Page 5 for footnotes.)

# Double & Triple Reduction/Helical-Worm/Worm Under

Dimensions — Inches (Smaller Sizes on Pages 98 & 99)

Type  
**WUH**

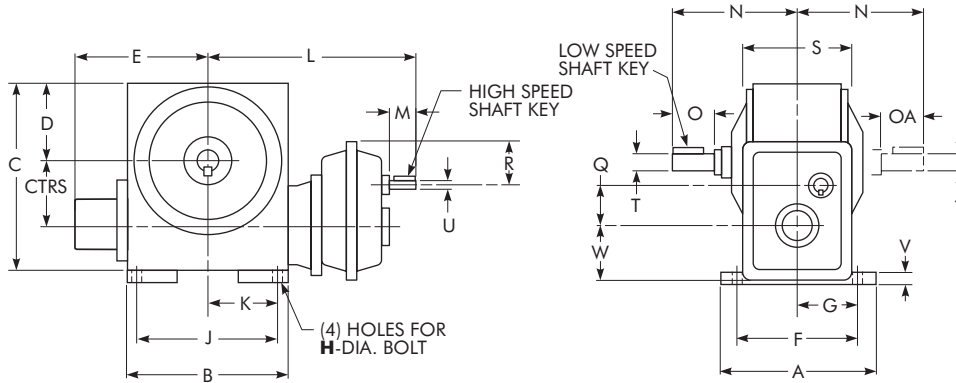

Type  
**WUHQ**

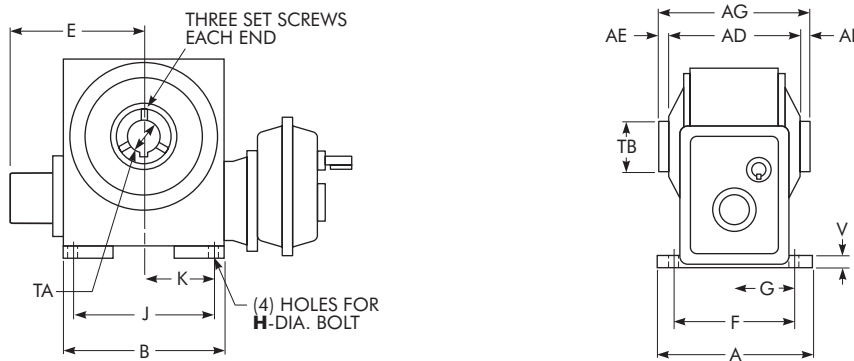

DRIVE SIZE ★	CTRS	A	B	C	D	E	F	G	H	J	K	L	M •	N	O †	OA †	Q	R	S
1700	7.00	13.38	15.38	20.33	5.74	10.63	11.25	5.63	1.13	13.00	6.50	19.68	2.50	11.76	5.69	5.69	3.49	8.10	10.36
1800	8.00	13.50	17.37	22.61	5.75	11.93	11.50	5.75	1.13	14.75	7.38	21.30	3.00	12.25	6.02	6.02	4.07	9.89	11.64
11000	10.00	16.88	21.24	27.12	6.76	14.34	14.00	7.00	1.44	17.00	8.50	25.78	3.50	14.75	6.80	6.80	4.90	11.83	13.85

DRIVE SIZE ★	Low Speed Shaft		Hollow Low Speed Shaft		High Speed Shaft		V	W	AD	AE	AG	AL	Approx. Wt – lb		
	T - .0005 - .0015	Key	TA Max ■ + .002 - .000	TB	Key	U + .0000 - .0005							Key	WUH	WUHQ
1700	2.7500	.625 x .625 x 4.00	3.938	4.92	1.000 x .750 x 7.00	1.1250	.250 x .250 x 2.25	1.42	4.11	11.36	1.09	13.50	1.09	510	510
1800	3.0000	.750 x .750 x 4.50	4.438	5.55	1.000 x .750 x 8.50	1.3750	.313 x .313 x 2.75	1.65	4.61	12.48	1.03	14.50	1.03	770	770
11000	3.7500	.875 x .875 x 5.00	5.438	6.67	1.250 x .938 x 12.00	1.5000	.375 x .375 x 3.25	1.65	5.82	15.78	1.39	18.50	1.39	1250	1250

(See Page 5 for footnotes.)

# Assemblies \*

Reverse all arrows for opposite rotation of high speed shaft.

## Double Reduction — Solid Output Shaft

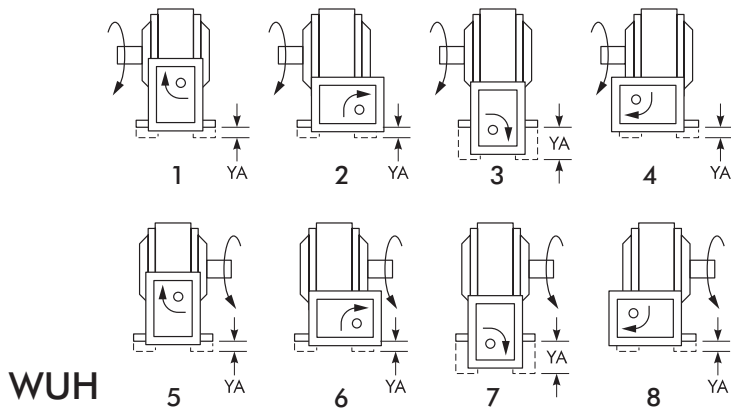

## Triple Reduction — Solid Output Shaft

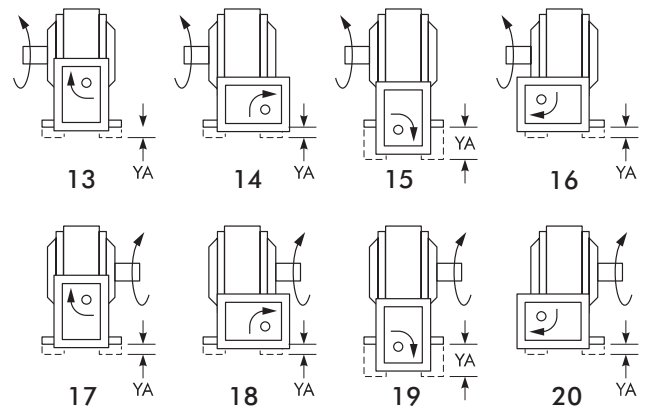

## Double Reduction — Double L.S. Shaft Extension

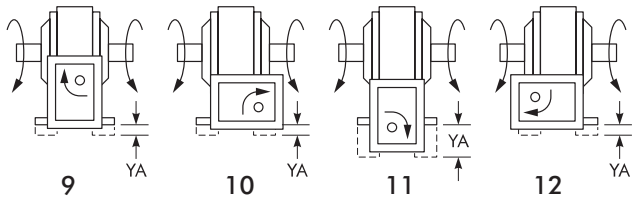

## Triple Reduction — Double L.S. Shaft Extension

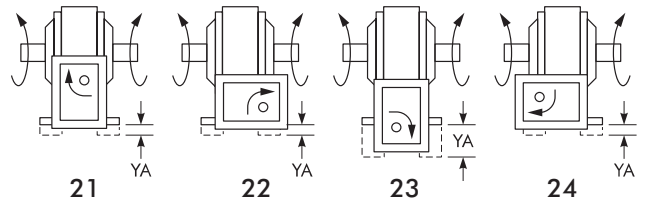

## Double Reduction — Hollow Output

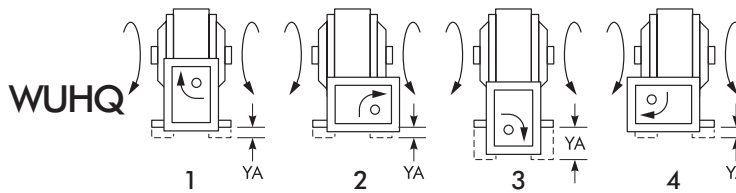

## Triple Reduction — Hollow Output

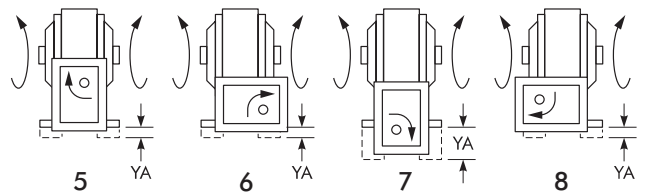

### DOUBLE REDUCTION RATIOS (Nominal)

25:1  
37.5:1  
50:1  
75:1  
100:1  
125:1  
150:1  
200:1  
300:1

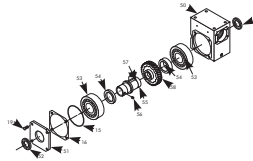

### TRIPLE REDUCTION RATIOS (Nominal)

138:1	560:1
185:1	625:1
210:1	700:1
250:1	750:1
280:1	840:1
350:1	1000:1
375:1	1250:1
420:1	1500:1
500:1	1750:1

## Dimension YA §

Assembly Numbers	DRIVE SIZE		
	1700	1800	11000
1, 5, 9, 13, 17, & 21	0	.25	.39
2, 6, 10, 14, 18, & 22	0	.25	.39
3, 7, 11, 15, 19, & 23	1.75	3.51	4.45
4, 8, 12, 16, 20, & 24	0	.25	.39

(See Page 5 for footnotes.)

# Double Reduction/Helical-Worm/Vertical Output (Larger Sizes on Page 108)

## Dimensions — Inches

Type  
**WXHM**

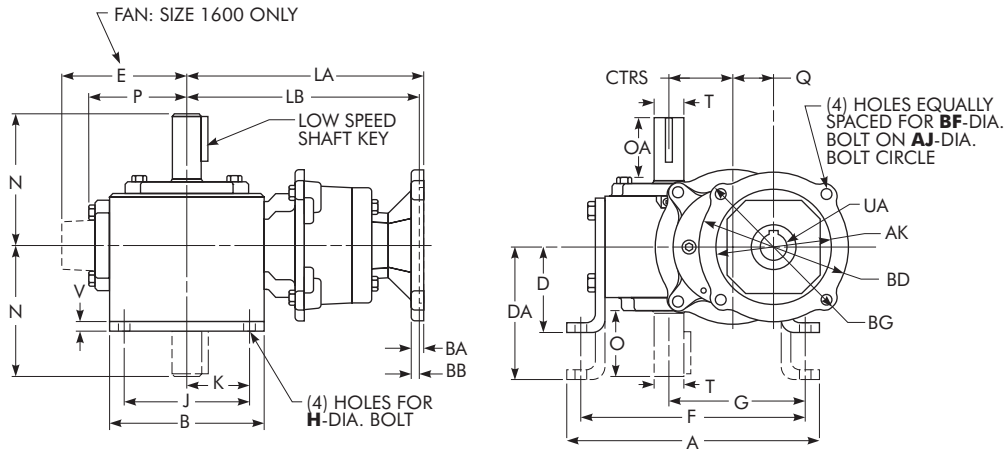

Type  
**WXH**

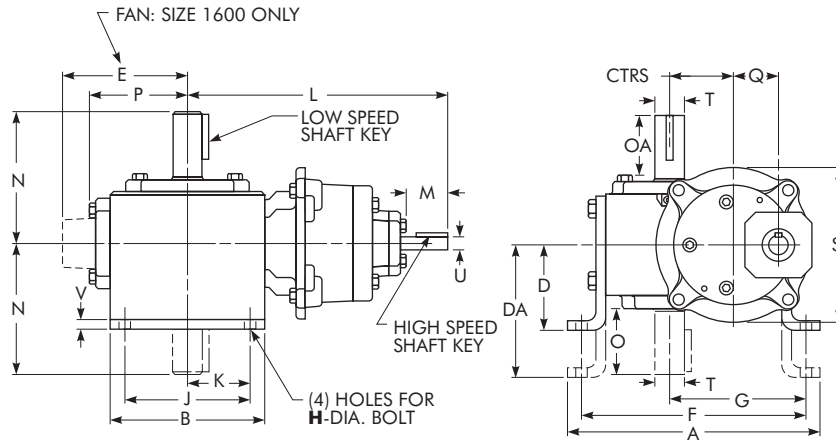

SEE PAGE 107 FOR MOTOR

(Continued on next page)

DRIVE SIZE ★	CTRS	A	B	D	E	F	G	H	J	K	L	M•	N	O♦	OA♦	P	Q	S
<b>1133</b>	1.33	7.26	4.00	2.63	...	6.50	3.86	.38	3.00	1.50	9.02	1.58	4.00	2.16	1.94	2.61	1.68	4.52
<b>1154</b>	1.54	7.88	5.00	3.00	...	7.00	4.28	.44	4.00	2.00	9.55	1.58	4.31	2.11	1.90	3.14	1.68	4.52
<b>1175</b>	1.75	8.25	5.00	3.00	...	7.37	4.50	.44	4.00	2.00	9.65	1.58	4.31	2.05	1.84	3.24	1.68	4.52
<b>1206</b>	2.06	9.38	6.00	3.13	...	8.38	5.09	.50	4.88	2.44	10.02	1.58	4.68	2.29	2.08	3.61	1.68	4.52
<b>1238</b>	2.38	9.94	6.00	3.38	...	8.81	5.38	.50	4.88	2.44	9.88	1.48	5.14	2.66	2.44	3.77	2.88	6.74
<b>1262</b>	2.63	11.24	7.00	3.63	...	10.12	6.12	.56	5.75	2.88	10.44	1.48	5.63	2.73	2.52	4.34	2.88	6.74
<b>1300</b>	3.00	12.50	8.00	3.94	...	11.13	6.75	.56	6.00	3.00	10.94	1.48	6.75	3.60	3.36	4.84	2.88	6.74
<b>1325</b>	3.25	13.00	8.50	4.69	...	11.88	7.13	.56	6.13	3.06	11.13	1.48	7.06	3.66	3.42	5.02	2.88	6.74
<b>1425</b>	4.25	16.26	10.00	5.00	...	14.88	8.69	.69	7.88	3.94	14.97	1.96	8.12	4.50	4.21	6.10	2.88	8.50
<b>1525</b>	5.25	19.62	13.00	5.16	...	18.00	10.88	.78	10.00	5.00	16.37	1.96	9.06	4.78	4.53	7.50	2.88	8.50
<b>1600</b>	6.00	23.26	14.75	7.31	10.24	20.88	12.19	.91	11.76	5.88	17.09	1.96	10.00	4.66	4.66	...	2.88	8.50

(See Page 5 for footnotes.)



Type  
**WXHQM**

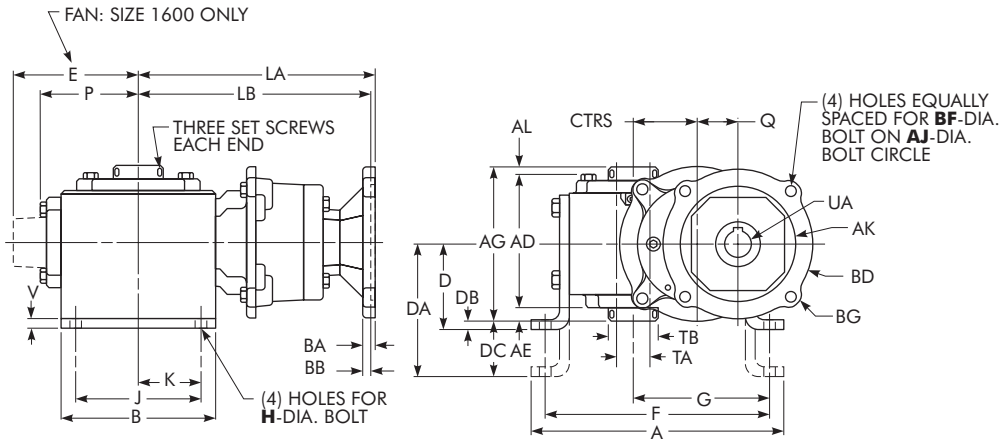

Type  
**WXHQ**

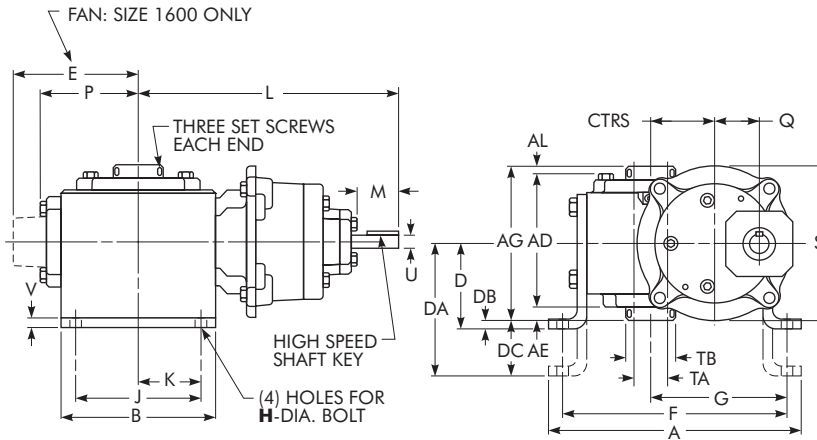

SEE PAGE 107 FOR MOTOR MOUNTING DIMENSIONS.

(Continued from preceding page)

DRIVE SIZE ★	Low Speed Shaft		Hollow Low Speed Shaft		High Speed Shaft		V	AD	AE	AG	AL	DA	DB	DC	Approx. Wt - lb				
	T -.0005 -.0015	Key	TA Max ■ +.002 -.000	TB	Key	U -.0005 -.0015									Key	WXH	WXHM	WXHQ	WXQM
<b>1133</b>	.6250	.188 x .188 x 1.50	.625	1.00	.188 x .188 x 1.50	.5000	.125 x .125 x 1.25	.25	3.90	.32	4.75	.53	3.56	.25	1.19	38	40	38	40
<b>1154</b>	.7500	.188 x .188 x 1.50	.625	1.00	.188 x .188 x 1.50	.5000	.125 x .125 x 1.25	.25	4.61	.30	5.42	.51	4.38	.29	1.67	44	46	44	46
<b>1175</b>	.8750	.188 x .188 x 1.38	1.000	1.44	.250 x .250 x 2.50	.5000	.125 x .125 x 1.25	.25	4.73	.28	5.50	.49	4.38	.25	1.63	45	47	46	48
<b>1206</b>	1.0000	.250 x .250 x 1.44	1.438	1.94	.375 x .313 x 3.00	.5000	.125 x .125 x 1.25	.38	4.99	.40	6.00	.61	4.88	.13	1.88	66	67	68	71
<b>1238</b>	1.1250	.250 x .250 x 1.75	1.438	1.94	.375 x .313 x 3.00	.6250	.188 x .188 x 1.25	.38	5.18	.31	6.00	.51	5.25	.38	2.25	77	79	78	80
<b>1262</b>	1.1250	.250 x .250 x 1.44	1.438	1.94	.375 x .313 x 3.00	.6250	.188 x .188 x 1.25	.38	6.01	.39	7.00	.60	5.56	.13	2.06	93	95	94	93
<b>1300</b>	1.2500	.250 x .250 x 2.25	1.938	2.51	.500 x .375 x 3.00	.6250	.188 x .188 x 1.25	.38	6.53	.36	7.50	.60	5.88	.19	2.13	117	119	115	119
<b>1325</b>	1.3750	.313 x .313 x 2.50	1.938	2.51	.500 x .375 x 3.00	.6250	.188 x .188 x 1.25	.38	7.04	.29	7.88	.54	6.25	.75	2.31	120	122	120	122
<b>1425</b>	1.8750	.500 x .500 x 3.06	2.188	2.75	.500 x .375 x 3.00	.8750	.188 x .188 x 1.50	.50	7.53	.34	8.50	.63	7.50	.75	3.25	208	212	208	212
<b>1525</b>	2.0000	.500 x .500 x 3.50	3.438	4.26	.875 x .688 x 4.00	.8750	.188 x .188 x 1.50	.50	8.85	.68	10.50	.97	9.16	-.09	3.91	316	320	316	320
<b>1600</b>	2.2500	.500 x .500 x 4.00	3.438	4.18	.875 x .688 x 4.00	.8750	.188 x .188 x 1.50	.50	10.52	.52	11.50	.52	9.63	1.56	3.88	405	409	405	409

# Assemblies \*

Reverse all arrows for opposite rotation of high speed shaft.

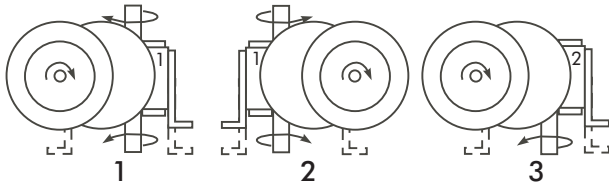

WXHM

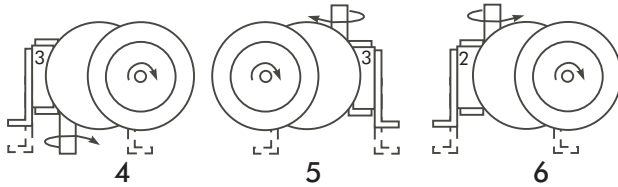

WXHQM

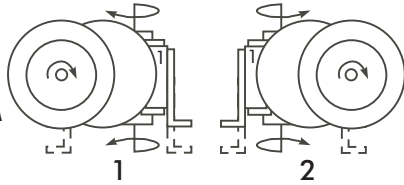

WXH

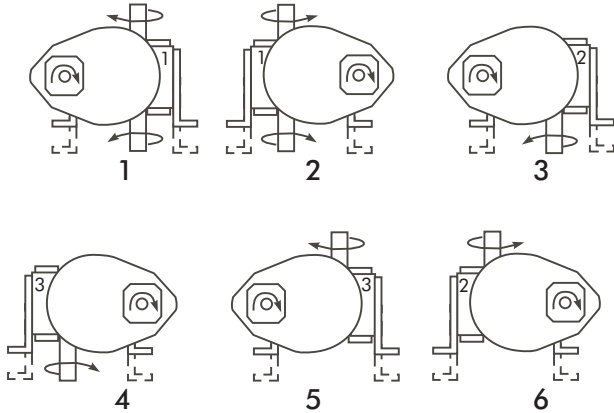

WXHQ

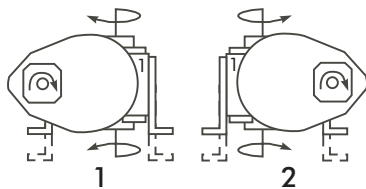

(See Page 5 for footnotes.)

# Motor Data

## NEMA Motor Flange Face Locations — Inches

DRIVE SIZE	56C/140TC	180TC	210TC
	LA	LB	LB
1133	8.12	...	...
1154	8.65	...	...
1175	8.75	...	...
1206	9.12	...	...
1238	9.88	...	...
1262	10.44	...	...
1300	10.94	...	...
1325	11.13	...	...
1425	13.79	14.23	14.23
1525	15.19	15.63	15.63
1600	15.91	16.35	16.35

## NEMA Motor Mounting Dimensions — Inches

FRAME SIZE	AJ	AK	BA	BB	BD	BF	BG	UA	Keyway
56C	5.88	4.50	.50	...	6.50 *	.41	6.50	.625	.1875 x .0938
140TC	5.88	4.50	.50	...	6.50 *	.41	6.50	.875	.1875 x .0938
180TC	7.25	8.50	...	.56	9.00	.53	9.00	1.125	.2500 x .1250
210TC	7.25	8.50	...	.56	9.00	.53	9.00	1.375	.3125 x .1562

(See Page 5 for footnotes.)

# Double & Triple Reduction/Helical-Worm/Vertical Output

Dimensions — Inches (Smaller Sizes on Pages 104 & 105)

Type  
**WXH**

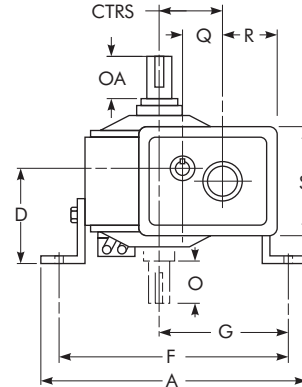
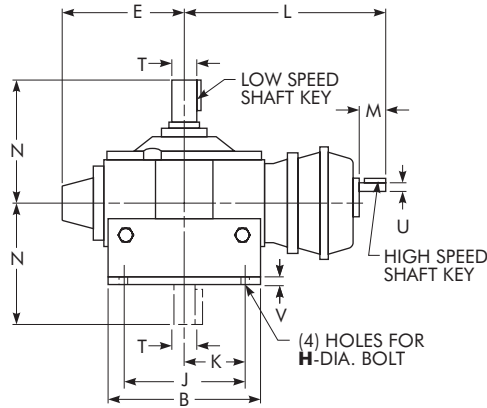

Type  
**WXHQ**

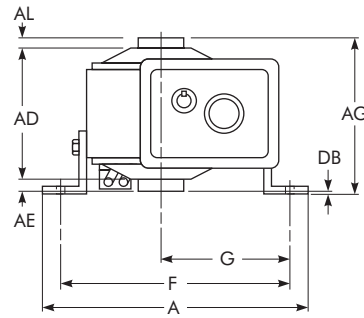
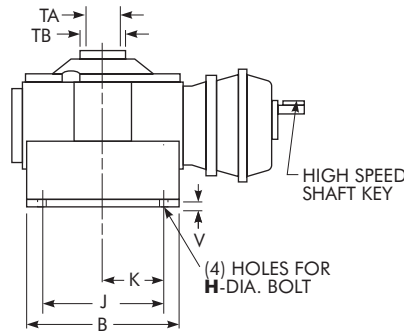

DRIVE SIZE ★	CTRS	A	B	D	E	F	G	H	J	K	L	M •	N	O +	OA +	Q	R	S
<b>1700</b>	7.00	26.91	14.88	7.00	10.63	23.99	13.87	1.13	12.50	6.25	19.68	2.50	11.76	5.69	5.69	3.49	7.59	10.36
<b>1800</b>	8.00	28.96	17.00	8.00	11.93	25.50	14.38	1.13	14.00	7.00	21.30	3.00	12.25	6.02	6.02	4.07	8.86	11.64
<b>11000</b>	10.00	37.47	20.88	9.00	14.34	30.75	17.76	1.44	17.75	8.88	25.78	3.50	14.75	6.80	6.80	4.90	10.36	13.85

DRIVE SIZE ★	Low Speed Shaft		Hollow Low Speed Shaft		High Speed Shaft		V	AD	AE	AG	AL	DB	Approx. Wt – lb		
	T - .0005 - .0015	Key	TA Max ■ + .002 - .000	TB	Key	U + .0000 - .0005							Key	WXH	WXHQ
<b>1700</b>	2.7498	.625 x .625 x 4.00	3.938	4.92	1.000 x .750 x 7.00	1.1250	.250 x .250 x 2.25	.75	11.36	1.09	13.50	1.09	.25	510	510
<b>1800</b>	2.9995	.750 x .750 x 4.50	4.438	5.55	1.000 x .750 x 8.50	1.3750	.313 x .313 x 2.75	.75	12.48	1.03	14.50	1.03	.75	770	770
<b>11000</b>	3.7495	.875 x .875 x 5.00	5.438	6.67	1.250 x .938 x 12.00	1.5000	.375 x .375 x 3.25	1.00	15.78	1.39	18.50	1.39	-.25	1250	1250

(See Page 5 for footnotes.)

# Assemblies Reverse all arrows for opposite rotation of high speed shaft.

## Double Reduction

WXH  
Low Speed Shaft  
Extension Up

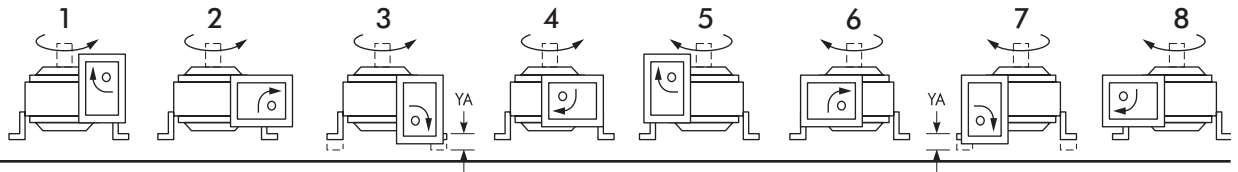

WXH  
Low Speed Shaft  
Extension Down

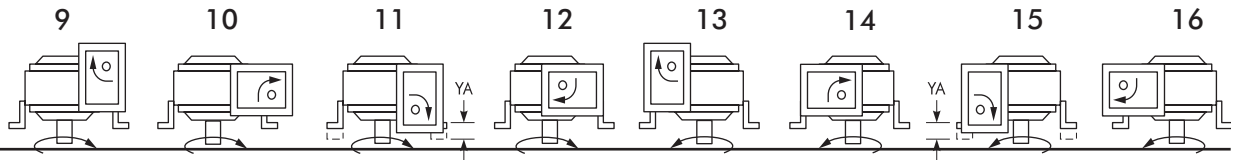

WXH  
Double Low  
Speed Shaft  
Extension

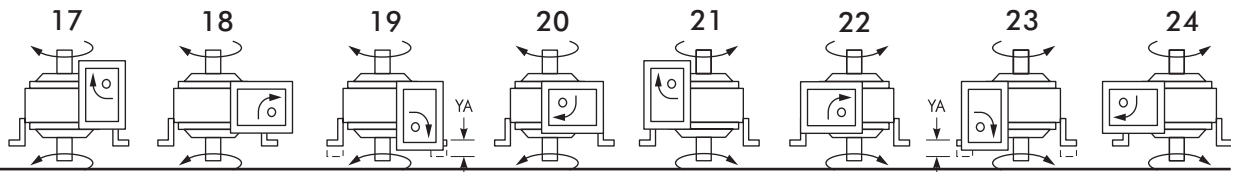

WXHQ  
Hollow Output

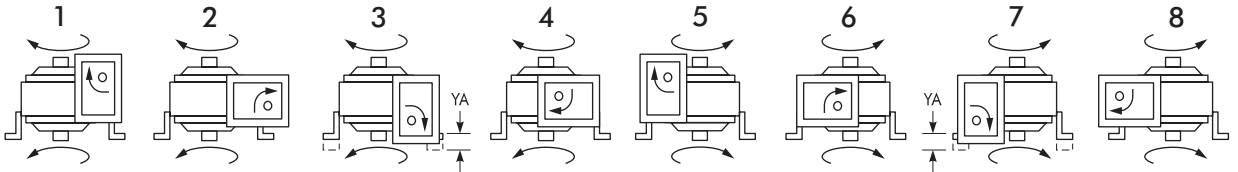

## Triple Reduction

WXH  
Low Speed Shaft  
Extension Up

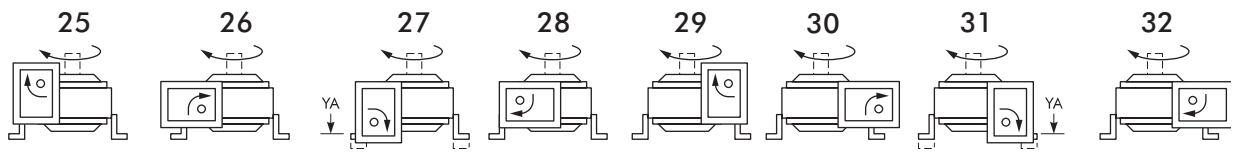

WXH  
Low Speed Shaft  
Extension Down

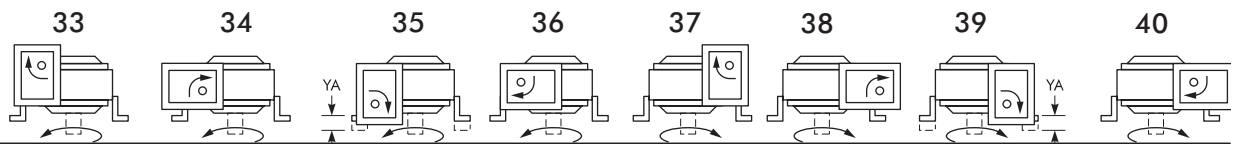

WXH  
Double Low  
Speed Shaft  
Extension

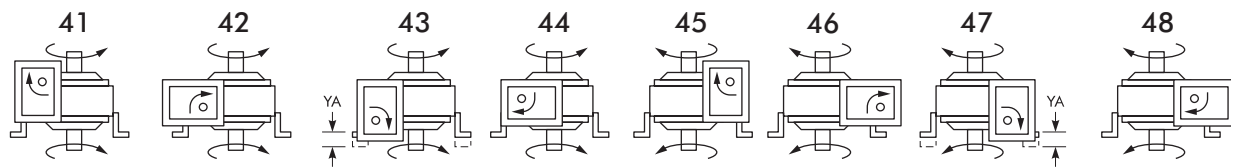

WXHQ  
Hollow Output

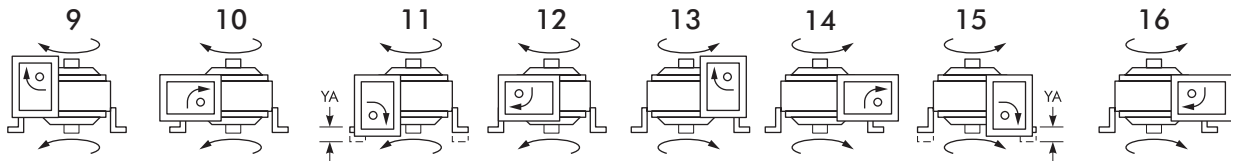

### DOUBLE REDUCTION RATIOS (Nominal)

25:1  
37.5:1  
50:1  
75:1  
100:1  
125:1  
150:1  
200:1  
300:1

L.S. SHAFT

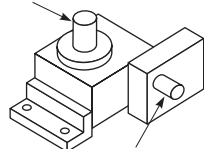

H.S. SHAFT

(See Page 5 for footnotes.)

### TRIPLE REDUCTION RATIOS (Nominal)

138:1  
185:1  
210:1  
250:1  
280:1  
350:1  
375:1  
420:1  
500:1

560:1  
625:1  
700:1  
750:1  
840:1  
1000:1  
1250:1  
1500:1  
1750:1

L.S. SHAFT

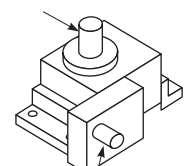

H.S. SHAFT

# Double Reduction/Helical-Worm/Vertical Input

Dimensions — Inches

Type  
**WJHM**

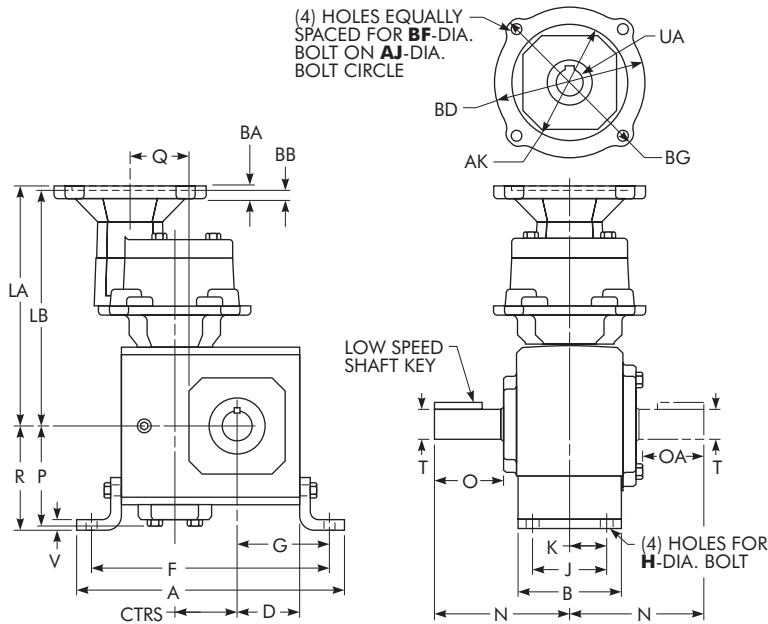

Type  
**WJH**

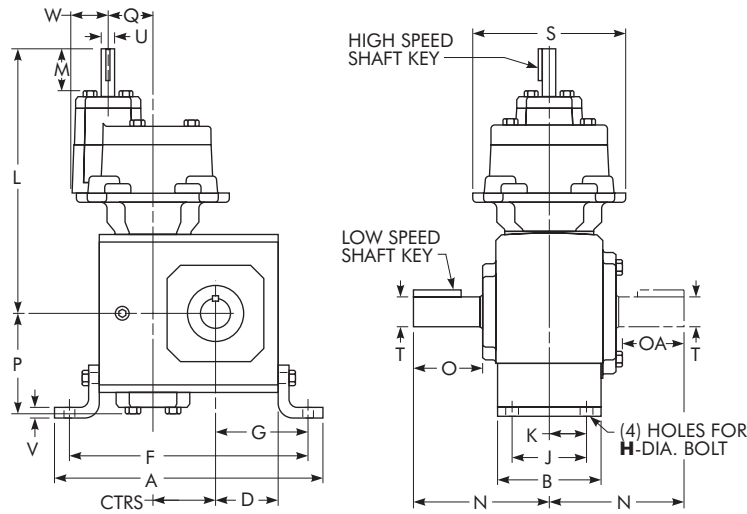

SEE PAGE 113 FOR MOTOR MOUNTING DIMENSIONS.

(Continued on next page)

DRIVE SIZE ★	CTRS	A	B	D	F	G	H	J	K	L	M •	N	O ♦	OA ♦	P	Q	R	S
<b>1133</b>	1.33	7.42	2.75	1.72	6.42	2.60	.38	2.00	1.00	9.02	1.58	4.00	2.16	1.94	2.61	1.68	2.94	4.52
<b>1154</b>	1.54	8.14	3.50	1.91	7.08	2.76	.44	2.75	1.38	9.55	1.58	4.31	2.11	1.90	3.14	1.68	3.50	4.52
<b>1175</b>	1.75	8.51	3.50	2.06	7.45	2.91	.44	2.75	1.38	9.65	1.58	4.31	2.05	1.84	3.24	1.68	3.50	4.52
<b>1206</b>	2.06	9.76	4.00	2.28	8.62	3.40	.50	2.75	1.38	10.02	1.58	4.68	2.29	2.08	3.61	1.68	4.01	4.52
<b>1238</b>	2.38	10.31	4.00	2.50	9.19	3.63	.50	2.88	1.44	9.88	1.48	5.14	2.66	2.44	3.77	2.88	4.06	6.74
<b>1262</b>	2.63	11.62	5.00	2.94	10.38	4.13	.56	3.38	1.69	10.44	1.48	5.63	2.73	2.52	4.34	2.88	5.00	6.74
<b>1300</b>	3.00	12.64	6.00	3.25	11.38	4.50	.56	3.88	1.94	10.94	1.48	6.75	3.60	3.36	4.84	2.88	5.62	6.74
<b>1325</b>	3.25	13.14	6.00	3.50	11.88	4.75	.56	3.88	1.94	11.13	1.48	7.06	3.66	3.42	5.02	2.88	5.63	6.74
<b>1425</b>	4.25	16.38	7.00	4.44	14.88	6.19	.69	5.00	2.50	14.97	1.96	8.12	4.50	4.21	6.10	2.88	6.50	8.50
<b>1525</b>	5.25	19.00	7.00	5.12	17.50	6.87	.69	5.81	2.91	16.37	1.96	9.06	4.78	4.53	7.50	2.88	7.75	8.50

(See Page 5 for footnotes.)

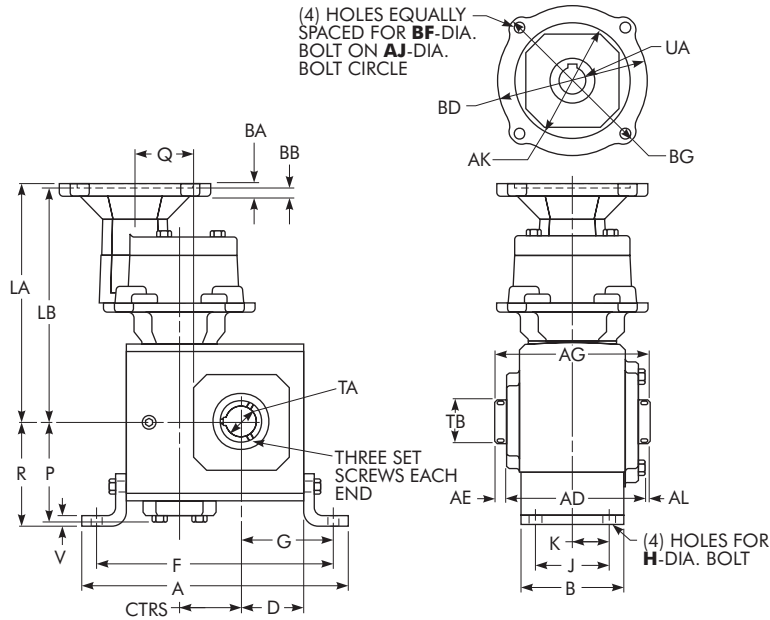

Type  
**WJHQM**

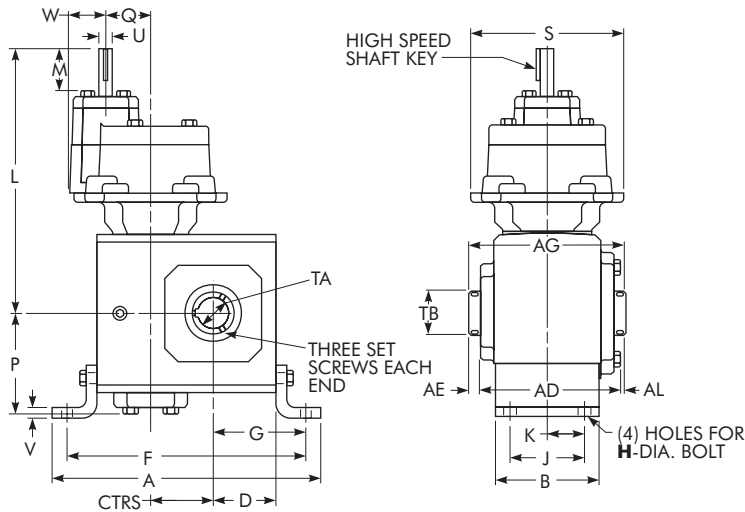

Type  
**WJHQ**

SEE PAGE 113 FOR MOTOR MOUNTING DIMENSIONS.

(Continued from preceding page)

DRIVE SIZE ★	Low Speed Shaft		Hollow Low Speed Shaft		High Speed Shaft		V	W	AD	AE	AG	AL	Approx. Wt – lb				
	T -.0005 -.0015	Key	TA Max ■ +.002 -.000	TB	Key	U -.0005 -.0015							Key	WJHM	WJH	WJHQM	WJHQ
<b>1133</b>	.6250	.188 x .188 x 1.50	.625	1.00	.188 x .188 x 1.50	.5000	.125 x .125 x 1.25	.25	1.37	3.90	.32	4.75	.53	36	38	36	39
<b>1154</b>	.7500	.188 x .188 x 1.50	.625	1.00	.188 x .188 x 1.50	.5000	.125 x .125 x 1.25	.25	1.37	4.61	.30	5.42	.51	42	44	42	44
<b>1175</b>	.8750	.188 x .188 x 1.38	1.000	1.44	.250 x .250 x 2.50	.5000	.125 x .125 x 1.25	.25	1.37	4.73	.28	5.50	.49	44	47	45	46
<b>1206</b>	1.0000	.250 x .250 x 1.44	1.438	1.94	.375 x .313 x 3.00	.5000	.125 x .125 x 1.25	.38	1.37	4.99	.40	6.00	.61	51	56	54	54
<b>1238</b>	1.1250	.250 x .250 x 1.75	1.438	1.94	.375 x .313 x 3.00	.6250	.188 x .188 x 1.25	.38	2.73	5.18	.31	6.00	.51	72	75	73	81
<b>1262</b>	1.1250	.250 x .250 x 1.44	1.438	1.94	.375 x .313 x 3.00	.6250	.188 x .188 x 1.25	.38	2.73	6.01	.39	7.00	.60	86	86	84	94
<b>1300</b>	1.2500	.250 x .250 x 2.25	1.938	2.51	.500 x .375 x 3.00	.6250	.188 x .188 x 1.25	.38	2.73	6.53	.36	7.50	.60	109	111	109	121
<b>1325</b>	1.3750	.313 x .313 x 2.50	1.938	2.51	.500 x .375 x 3.00	.6250	.188 x .188 x 1.25	.38	2.73	7.04	.29	7.88	.54	112	114	112	124
<b>1425</b>	1.8750	.500 x .500 x 3.06	2.188	2.75	.500 x .375 x 3.00	8750	.188 x .188 x 1.50	.50	1.75	7.53	.34	8.50	.63	191	195	191	190
<b>1525</b>	2.0000	.500 x .500 x 3.50	3.438	4.26	.875 x .688 x 4.00	8750	.188 x .188 x 1.50	.50	1.75	8.85	.68	10.50	.97	299	303	299	303

# Assemblies \*

Reverse all arrows for opposite rotation of high speed shaft. Refer to assembly A or B for low speed rotation relative to high speed shaft position.

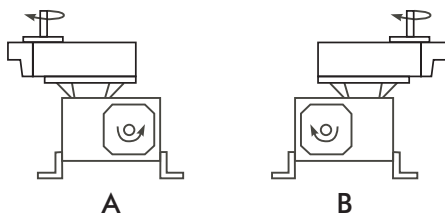
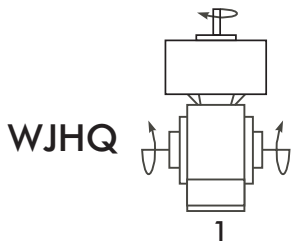
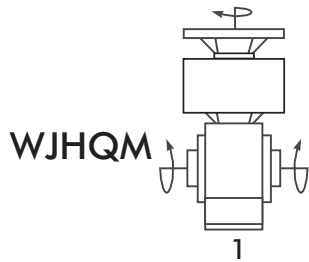
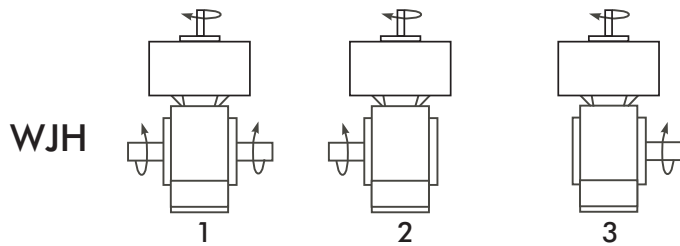
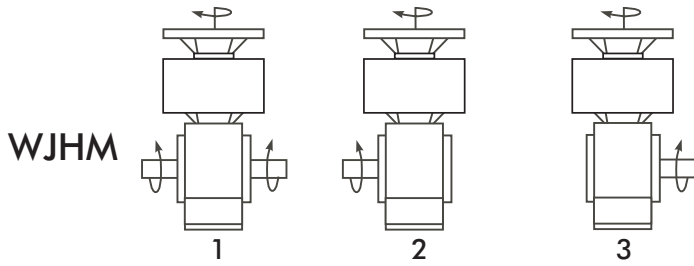

(See Page 5 for footnotes.)



# Motor Data

## NEMA Motor Flange Face Locations — Inches

DRIVE SIZE	56C/140TC	180TC	210TC
	LA	LB	LB
1133	8.12	...	...
1154	8.65	...	...
1175	8.75	...	...
1206	9.12	...	...
1238	9.88	...	...
1262	10.44	...	...
1300	10.94	...	...
1325	11.13	...	...
1425	13.79	14.23	14.23
1525	15.19	15.63	15.63

## NEMA Motor Mounting Dimensions — Inches

FRAME SIZE	AJ	AK	BA	BB	BD	BF	BG	UA	Keyway
56C	5.88	4.50	.50	...	6.50 *	.41	6.50	.625	.1875 x .0938
140TC	5.88	4.50	.50	...	6.50 *	.41	6.50	.875	.1875 x .0938
180TC	7.25	8.50	...	.56	9.00	.53	9.00	1.125	.2500 x .1250
210TC	7.25	8.50	...	.56	9.00	.53	9.00	1.375	.3125 x .1562

(See Page 5 for footnotes.)

# Double Reduction/Helical-Worm/Flanged Output

Dimensions — Inches

Type  
**WLHM**

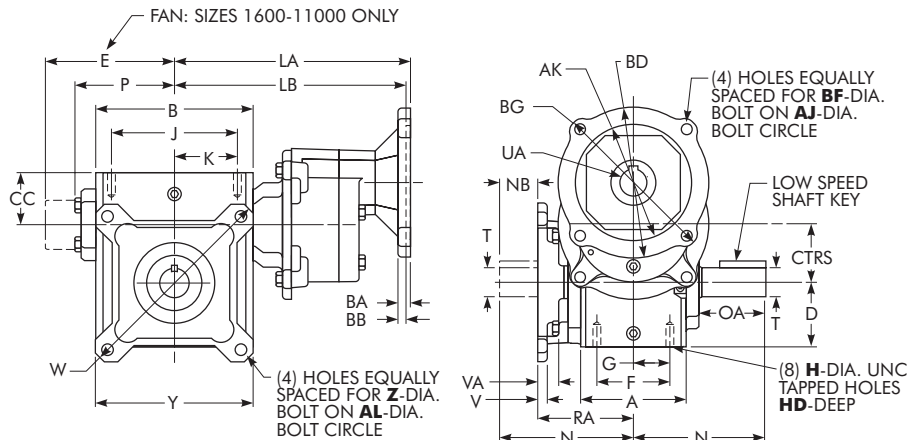

Type  
**WLH**

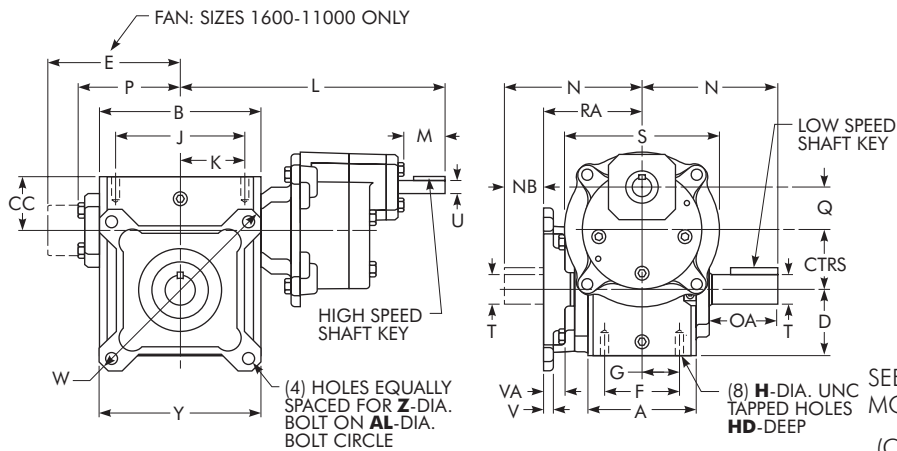

SEE PAGE 117 FOR MOTOR MOUNTING DIMENSIONS.

(Continued on next page)

DRIVE SIZE *	CTRS	A	B	D	E	EA	F	G	H	HD	J	K	L	M •	N	OA •	P	Q	R	S	Low Speed Shaft	
																					T - .0005 - .0015	Key
1133	1.33	2.82	3.80	1.72	...	...	2.00	1.00	.3125-18	.50	3.25	1.63	9.02	1.58	4.00	2.16	2.61	1.68	1.37	4.52	.6250	.188 x .188 x 1.50
1154	1.54	3.44	4.88	1.91	...	...	2.75	1.38	.3125-18	.63	4.19	2.09	9.55	1.58	4.31	2.11	3.14	1.68	1.37	4.52	.7500	.188 x .188 x 1.50
1175	1.75	3.56	5.06	2.06	...	...	2.75	1.38	.3125-18	.63	4.19	2.09	9.65	1.58	4.31	2.05	3.24	1.68	1.37	4.52	.8750	.188 x .188 x 1.38
1206	2.06	3.81	5.80	2.28	...	...	3.00	1.50	.3125-18	.63	4.75	2.38	10.02	1.58	4.68	2.29	3.61	1.68	1.37	4.52	1.0000	.250 x .250 x 1.44
1238	2.38	4.06	6.12	2.50	...	...	2.88	1.44	.3750-16	.56	5.00	2.50	9.88	1.48	5.14	2.66	3.77	2.88	2.73	6.74	1.1250	.250 x .250 x 1.75
1262	2.63	4.84	7.12	2.94	...	...	3.38	1.69	.3750-16	.69	6.38	3.19	10.44	1.48	5.63	2.73	4.34	2.88	2.73	6.74	1.1250	.250 x .250 x 1.44
1300	3.00	5.25	8.12	3.25	...	...	4.00	2.00	.4375-14	.88	7.00	3.50	10.94	1.48	6.75	3.60	4.84	2.88	2.73	6.74	1.2500	.250 x .250 x 2.25
1325	3.25	5.75	8.50	3.50	...	...	4.00	2.00	.4375-14	.88	7.50	3.75	11.13	1.48	7.06	3.66	5.02	2.88	2.73	6.74	1.3750	.313 x .313 x 2.50
1425	4.25	6.13	10.25	4.44	...	...	5.00	2.50	.6250-11	1.00	8.50	4.25	14.97	1.96	8.12	4.50	6.10	2.88	1.75	8.50	1.8750	.500 x .500 x 3.06
1525	5.25	7.19	13.00	5.12	...	...	5.81	2.91	.6250-11	1.25	11.00	5.50	16.37	1.96	9.06	4.78	7.50	2.88	1.75	8.50	2.0000	.500 x .500 x 3.50
1600	6.00	8.13	14.25	6.50	11.13	10.24	6.38	3.19	.6250-11	1.00	12.75	6.38	17.09	1.96	10.00	4.66	...	2.88	1.75	8.50	2.2500	.500 x .500 x 4.00

(See Page 5 for footnotes.)

Type  
**WLHQM**

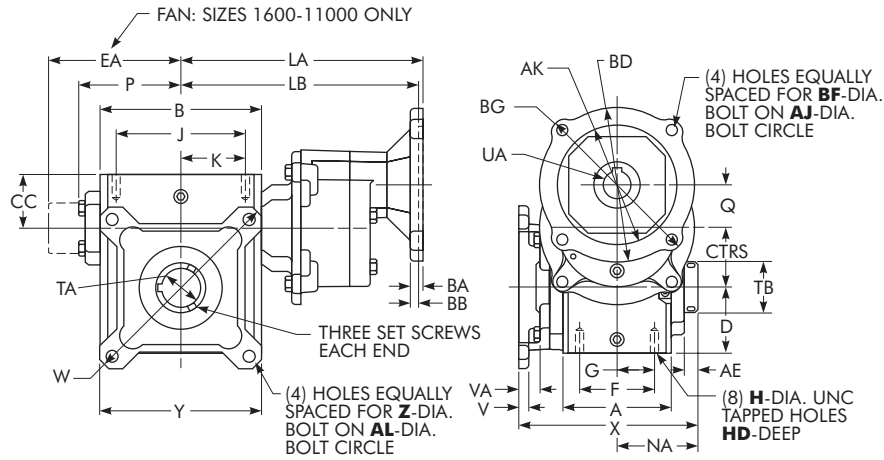

Type  
**WLHQ**

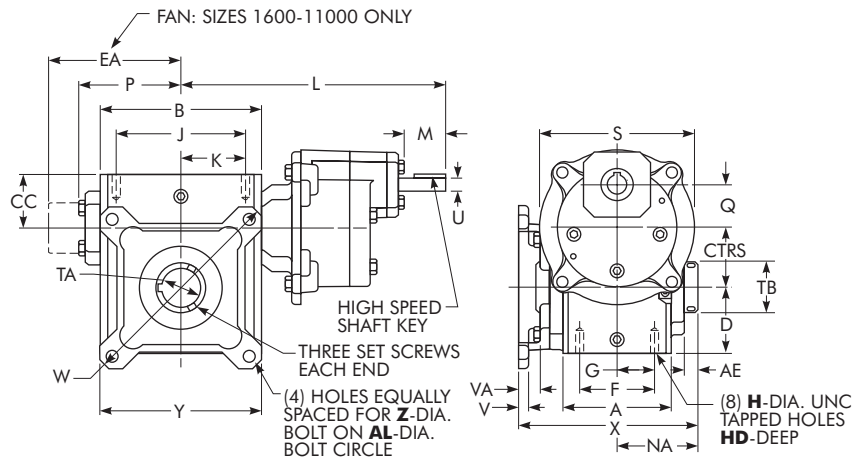

SEE PAGE 117 FOR MOTOR MOUNTING DIMENSIONS.

(Continued from preceding page)

DRIVE SIZE	Hollow Low Speed Shaft		High Speed Shaft		V	W	X	Y	Z	AE	AL	CC	NA	NB	RA	VA	Approx. Wt - lb				
	TA Max = +.002 -.000	TB	Key	U -.0005 -.0015													Key	WLHM	WLH	WLQM	WLHQ
<b>1133</b>	.625	1.00	.188 x .188 x 1.50	.500	.125 x .125 x 1.25	.38	5.92	4.90	4.50	.34	.53	5.00	1.61	2.38	1.48	2.52	.08	39	37	39	37
<b>1154</b>	.625	1.00	.188 x .188 x 1.50	.500	.125 x .125 x 1.25	.38	5.92	5.59	4.50	.34	.51	5.00	1.93	2.71	1.44	2.88	.08	44	42	44	42
<b>1175</b>	1.000	1.44	.250 x .250 x 2.50	.500	.125 x .125 x 1.25	.38	6.64	5.94	5.00	.34	.49	5.88	1.94	2.75	1.13	3.19	.11	46	44	47	45
<b>1206</b>	1.438	1.94	.375 x .313 x 3.00	.500	.125 x .125 x 1.25	.44	7.88	6.69	5.99	.41	.61	7.00	2.03	3.00	.99	3.69	.55	54	52	57	55
<b>1238</b>	1.438	1.94	.375 x .313 x 3.00	.625	.188 x .188 x 1.25	.44	8.39	6.73	6.27	.41	.51	7.50	2.06	3.00	1.47	3.67	.51	81	79	82	80
<b>1262</b>	1.438	1.94	.375 x .313 x 3.00	.625	.188 x .188 x 1.25	.50	8.88	7.20	6.67	.41	.60	8.00	2.44	3.50	1.99	3.64	.04	94	92	92	90
<b>1300</b>	1.938	2.51	.500 x .375 x 3.00	.625	.188 x .188 x 1.25	.50	9.89	7.53	7.37	.41	.60	9.00	2.63	3.75	3.03	3.72	.07	121	119	121	119
<b>1325</b>	1.938	2.51	.500 x .375 x 3.00	.625	.188 x .188 x 1.25	.50	9.89	7.97	7.37	.41	.54	9.00	2.63	3.94	3.08	3.98	.07	124	122	124	122
<b>1425</b>	2.188	2.75	.500 x .375 x 3.00	.875	.188 x .188 x 1.50	.62	12.95	8.81	9.65	.56	.63	11.50	2.69	4.25	3.62	4.50	.06	190	186	190	186
<b>1525</b>	3.438	4.26	.875 x .688 x 4.00	.875	.188 x .188 x 1.50	.75	15.50	10.87	11.75	.69	.97	14.00	3.63	5.25	3.50	5.56	.34	303	299	303	299
<b>1600</b>	3.438	4.18	.875 x .688 x 4.00	.875	.188 x .188 x 1.50	.75	18.00	13.01	6.87	.69	.52	15.63	4.00	5.75	2.78	7.22	1.38	394	390	394	390

# Assemblies \*

Reverse all arrows for opposite rotation of high speed shaft.

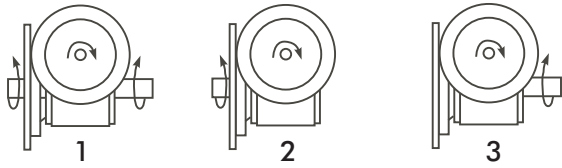

**WLHM**

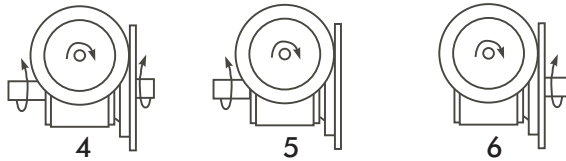

**WLHQM**

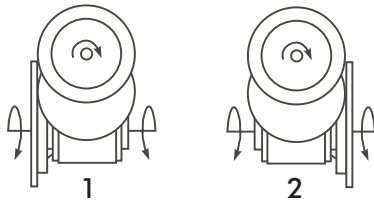

**WLH**

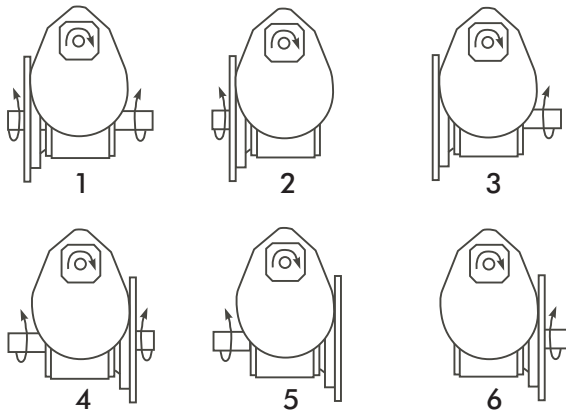

**WLHQ**

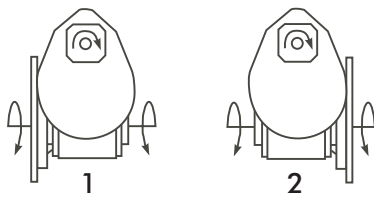

(See Page 5 for footnotes.)

# Motor Data

## NEMA Motor Flange Face Locations — Inches

DRIVE SIZE	56C/140TC	180TC	210TC
	LA	LB	LB
1133	8.12	...	...
1154	8.65	...	...
1175	8.75	...	...
1206	9.12	...	...
1238	9.88	...	...
1262	10.44	...	...
1300	10.94	...	...
1325	11.13	...	...
1425	13.79	14.23	14.23
1525	15.19	15.63	15.63
1600	15.91	16.35	16.35

## NEMA Motor Mounting Dimensions — Inches

FRAME SIZE	AJ	AK	BA	BB	BD	BF	BG	UA	Keyway
56C	5.88	4.50	.50	...	6.50 <sup>♣</sup>	.41	6.50	.625	.1875 x .0938
140TC	5.88	4.50	.50	...	6.50 <sup>♣</sup>	.41	6.50	.875	.1875 x .0938
180TC	7.25	8.50	...	.56	9.00	.53	9.00	1.125	.2500 x .1250
210TC	7.25	8.50	...	.56	9.00	.53	9.00	1.375	.3125 x .1562

(See Page 5 for footnotes.)

# Selection Guide/Extended Output Shaft Drives

## Type WR

Select extended output shaft reducers using the Rating Table Method shown on Page 119.

Step 4, select drive configuration from below, then refer to Page 119 to select drive size and check overhung load.

Step 5, load connection factors ( $F_c$ ) are listed on Page 119.

Step 7, Check drive dimensions — Pages 120-129.

## Overhead Conveyor Drive

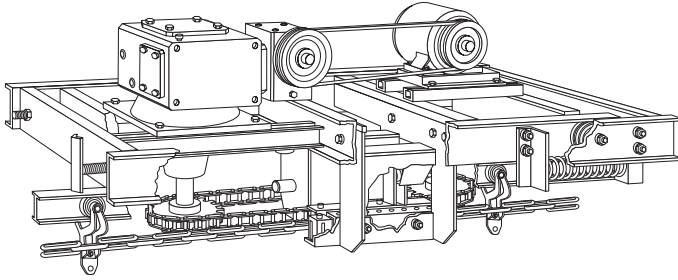

### Single Reduction

Ratings — Pages 24-27

Dimensions — Pages 120-123

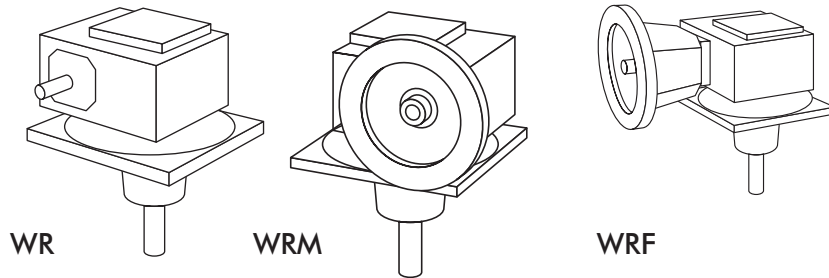

WR

WRM

WRF

### Double Reduction Worm-Worm

Ratings — Pages 54-57

Dimensions — Pages 124-127

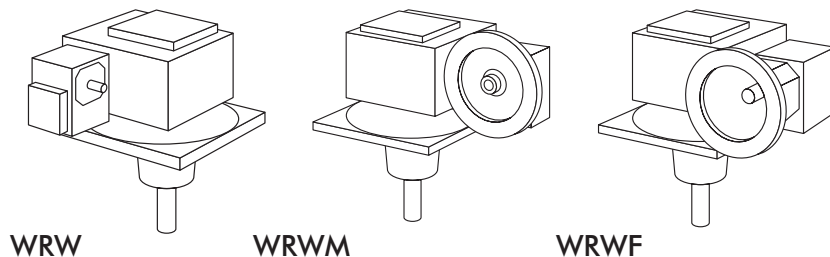

WRW

WRWM

WRWF

### Double Reduction Helical-Worm

Ratings — Page 82-85

Dimensions — Pages 128-129

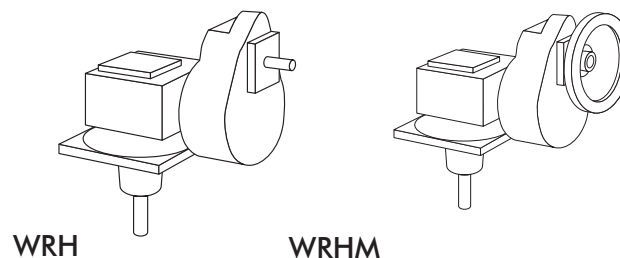

WRH

WRHM

# Overhung Load

## Single and Double Reduction Input Shaft Overhung Load — Pounds

DRIVE SIZE	1133	1154	1175	1206	1237	1262	1300	1325	1425	1525	1600	1700	1800	11000
Single Reduction	75	75	75	75	125	125	150	150	175	300	450	450	450	500
Double Reduction Worm Worm	75	75	75	75	75	75	75	75	75	125	150	150	175	300
Double Reduction Helical Worm	75	75	75	75	75	75	75	75	150	150	150	175	300	450

## Single and Double Reduction Output Shaft Overhung Load — Pounds

DRIVE SIZE	1300	1325	1425	1525	1600	1700	1800	11000
O.H.L.	605	959	1200	2524	2245	3791	4850	8500

## L<sub>f</sub> — Load Location Factors for Output Shafts

Distance From End of Shaft In Inches ×	DRIVE SIZE					
	1425	1525	1600	1700	1800	11000
0	1.00	1.00	1.00	1.00	1.00	1.00
0.5	1.03	1.03	1.02	1.02	1.02	1.02
1.0	1.06	1.06	1.04	1.04	1.04	1.03
1.5	1.09	1.09	1.06	1.06	1.05	1.05
2.0	1.12	1.12	1.09	1.08	1.07	1.06
2.5	1.16	1.15	1.11	1.10	1.09	1.08
3.0	1.20	1.19	1.14	1.13	1.11	1.10
3.5	1.24	1.23	1.16	1.15	1.13	1.12
4.0	1.28	1.27	1.19	1.17	1.15	1.14
4.5	1.32	1.32	1.22	1.20	1.18	1.16
5.0	1.37	1.36	1.25	1.23	1.20	1.18
5.5	1.43	1.42	1.28	1.26	1.23	1.20
6.0	...	...	1.31	1.29	1.25	1.22
6.5	...	...	1.35	1.32	1.28	1.24
7.0	...	...	1.39	1.35	1.31	1.27
7.5	...	...	1.42	1.38	1.33	1.29
8.0	...	...	...	...	1.36	1.31
8.5	...	...	...	...	1.40	1.34
9.0	...	...	...	...	1.43	1.37

\* Distance is in inches from the end of output shaft (inward towards housing). Interpolate for load location factors at intermediate distances. For example, the load location factor is 1.21 for size 1525 when distance is 3.25 inches.

## Consult Factory for Higher Input Shaft Overhung Ratings

In many cases, overhung load capacity in excess of that published is available. Published ratings are based on a combination of the most unfavorable conditions of rotation, speed, direction of applied load and drive loading. If the actual load should exceed the published capacity, refer full details to the Factory.

## Input Shaft OHL

Calculate the input shaft overhung load using the following formula:

$$\text{Input OHL} = \frac{126,000 \times \text{motor hp} \times F_c \times L_f}{\text{pitch diameter} \times \text{input rpm}}$$

Where:

F<sub>c</sub> = load connection factor (below)

L<sub>f</sub> = load location factor — the input shaft OHL is assumed to be applied at one shaft diameter from the seal cage, (L<sub>f</sub> = 1.0).

If the calculated overhung load exceeds the capacity shown above or if the load is applied at a distance greater than one shaft diameter from the seal cage, refer the application to the Factory.

## Load Connection Factor (F<sub>c</sub>)

Type of Connection	Factor
Sprocket or Timing Belt	1.00
Machined Pinion & Gear†	1.25
V-Belt	1.50
Flat-Belt	2.00
Synchronous (Timing) Belts†	1.30

▼ Refer all multiple chain, sprocket, and pinion mounted applications to Factory for deflection analysis.

# Single Reduction/Extended Output Shaft

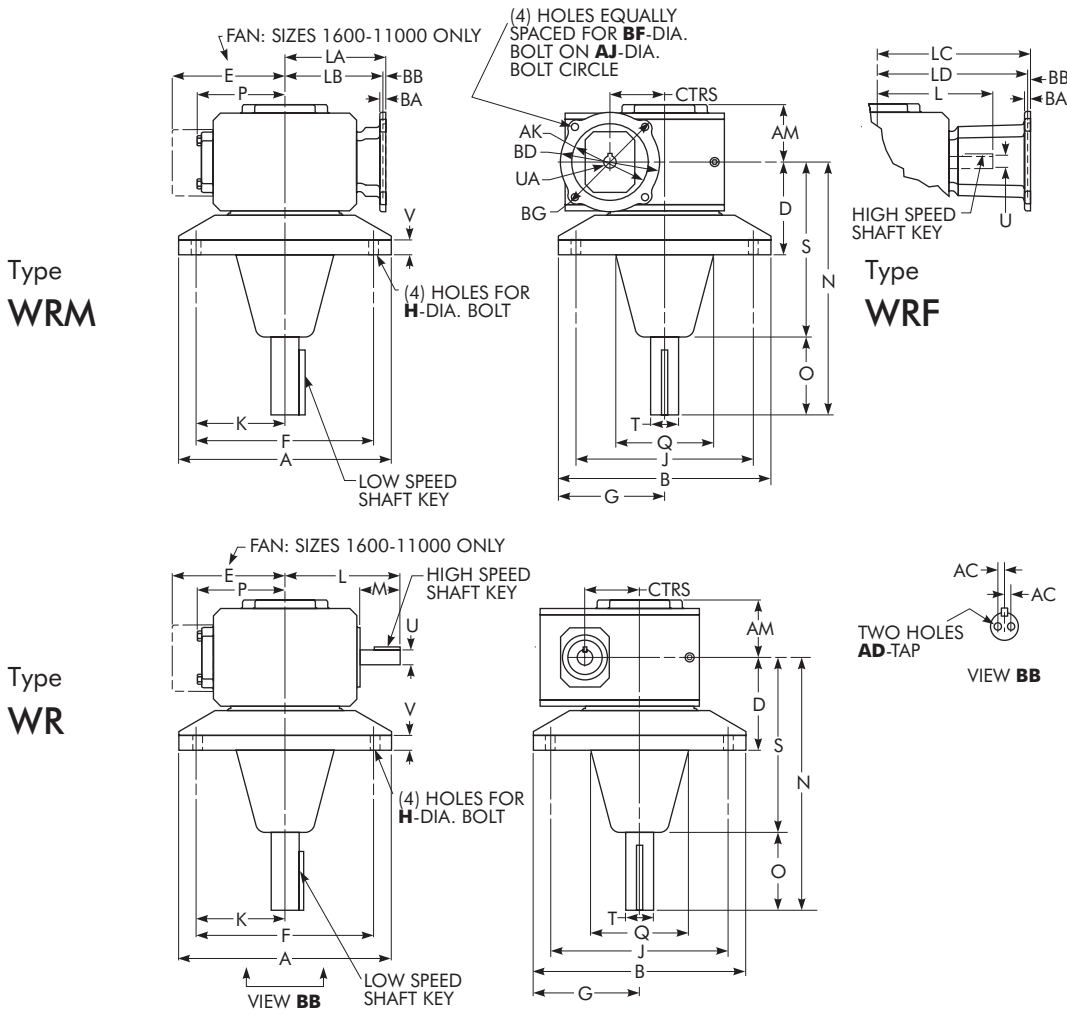

SEE PAGE 123 FOR MOTOR MOUNTING DIMENSIONS.

(Continued on next page)

DRIVE SIZE ★	CTRS	A	B	D	E	F	G	H	J	K	L	M •	N	O ♦	P
1300	3.00	11.00	11.00	4.60	...	9.00	5.50	.56	9.00	4.50	6.57	2.38	14.38	4.96	4.84
1325	3.25	12.50	12.50	5.52	...	10.50	6.25	.56	10.50	5.25	6.76	2.38	15.00	4.63	5.02
1425	4.25	14.00	14.00	5.74	...	12.00	7.00	.69	12.00	6.00	9.57	3.47	16.50	5.91	6.10
1525	5.25	16.00	16.00	6.00	...	14.00	8.00	.81	14.00	7.00	10.88	3.38	16.50	5.62	7.50
1600	6.00	19.50	19.50	7.00	11.13	17.00	9.75	.88	17.00	8.50	11.78	3.41	22.50	7.63	...
1700	7.00	22.00	22.00	8.50	11.37	19.00	11.00	1.13	19.00	9.50	11.50	2.97	24.00	7.63	...
1800	8.00	28.00	28.00	10.00	12.52	24.00	14.00	1.31	24.00	12.00	12.50	2.84	27.06	9.25	...
11000	10.00	32.00	32.00	12.50	14.69	28.00	16.00	1.31	28.00	14.00	15.50	3.76	29.50	9.43	...

(See Page 5 for footnotes.)



**Note:**

**Omnibox Extended Output Shaft Drivers**

feature mounting and output shaft dimensions which are interchangeable with major competition:

Omnibox Size	Falk Center Distance	Competitive Size Center Distance
1300	3.000"	3.0"
1325	3.250"	3.5"
1425	4.250"	4.0"
1525	5.250"	5.0"
1600	6.000"	6.0"
1700	7.000"	7.0"
1800	8.000"	9.0"
11000	10.000"	11.0"

(Continued from preceding page)

DRIVE SIZE ★	Q	S	Low Speed Shaft		High Speed Shaft Key		V	AC	AD Dia x Depth	AM	Approx. Wt – lb		
			T	Key	U	Key					WRM	WRF	WR
			-.0005 -.0015		-.0005 -.0015								
1300	5.12	9.42	1.4380	.375 x .375 x 3.88	.8750	.188 x .188 x 1.75	.78	.375	.31-18 UNC X 1.00	3.15	103	114	99
1325	5.75	10.37	1.6250	.375 x .375 x 3.69	.8750	.188 x .188 x 1.75	.88	.375	.31-18 UNC X 1.00	3.40	105	116	101
1425	6.75	10.59	1.6880	.375 x .375 x 4.68	1.2500	.250 x .250 x 2.88	1.00	.500	.38-16 UNC X 1.00	3.62	176	184	166
1525	8.00	10.88	2.1880	.500 x .500 x 4.63	1.2500	.250 x .250 x 3.00	1.25	.750	.38-16 UNC X 1.00	4.28	268	275	263
1600	9.50	14.87	2.4380	.625 x .625 x 6.50	1.5000	.375 x .375 x 3.00	1.50	.750	.38-16 UNC X 1.00	5.28	376	383	363
1700	10.75	16.37	2.9370	.750 x .750 x 6.44	1.6250	.375 x .375 x 2.87	1.75	1.000	.38-16 UNC X 1.00	6.06	...	590	560
1800	13.75	17.81	3.4380	.875 x .875 x 8.00	1.8750	.500 x .500 x 2.81	2.00	1.062	.62-11 UNC X 1.50	6.22	...	810	780
11000	17.00	20.07	3.9380	1.000 x 1.000 x 7.75	2.2500	.500 x .500 x 3.69	2.25	1.188	.62-11 UNC X 1.50	7.94	...	...	1180

---

# Assemblies \*

Reverse all arrows for opposite rotation of high speed shaft.

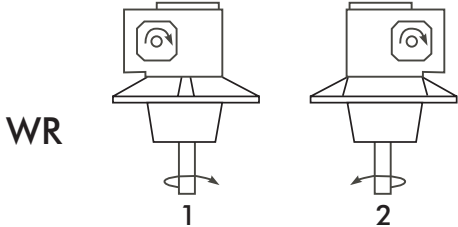
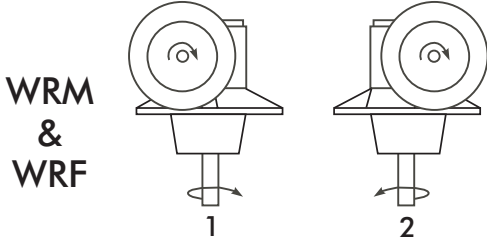

(See Page 5 for footnotes.)

# Motor Data

## NEMA Motor Flange Face Locations — Inches

DRIVE SIZE	56C/140TC		180TC		210TC		250TC	
	LA	LC	LB	LD	LB	LD	LB	LD
1300	5.69	8.82	6.12	9.82	6.56	9.82	...	...
1325	5.88	9.01	6.31	10.01	6.75	10.01	...	...
1425	6.45	11.81	7.21	12.90	7.21	12.90	7.77	13.46
1525	7.85	13.21	8.61	14.30	8.61	14.30	9.17	14.86
1600	10.45	...	9.33	15.88	9.33	15.88	9.94	16.50
1700	...	...	...	15.50	...	15.50	...	15.50
1800	...	...	...	...	...	16.58	...	16.58

## NEMA Motor Mounting Dimensions — Inches

FRAME SIZE	AJ	AK	BA	BB	BD	BF	BG	UA	Keyway
56C	5.88	4.50	.38	...	5.88	.41	6.64	.625	.1875 x .0938
140TC	5.88	4.50	.38	...	5.88	.41	6.64	.875	.1875 x .0938
180TC	7.25	8.50	...	.50	9.00	.53	...	1.125	.2500 x .1250
210TC	7.25	8.50	...	.50	9.00	.53	...	1.375	.3125 x .1875
250TC	7.25	8.50	...	.50	9.00	.53	...	1.625	.3750 x .1875

## IEC B5 & B3/B5 Motor Flange Dimensions \* — Inches

DRIVE SIZE	D71D	D80D	D90D	D100LD/D112MD	D132D
	LA	LA	LA	LA	LA
1300	4.78	5.41	5.41	5.80	...
1325	4.97	5.59	5.59	5.99	...
1425	...	...	6.38	6.39	7.17
1525	...	...	7.78	7.78	8.57

## IEC B5 & B3/B5 Metric Motor Mounting Dimensions — Millimeters

FRAME SIZE	AJ	AK	BA	BD	BF	BG	UA	Keyway
D71D	130	110	11	132	M8 x 1.25	146	14	5 x 2.5
D80D	165	130	15	165	M10 x 1.50	184	19	6 x 3.0
D90D	165	130	15	165	M10 x 1.50	184	24	8 x 3.5
D100LD/D112MD	215	180	18	216	M12 x 1.75	237	28	8 x 3.5
D132D	265	230	18	267	M12 x 1.75	290	38	10 x 4.0

(See Page 5 for footnotes.)

# Double Reduction/Worm-Worm/Extended Output Shaft

Dimensions — Inches

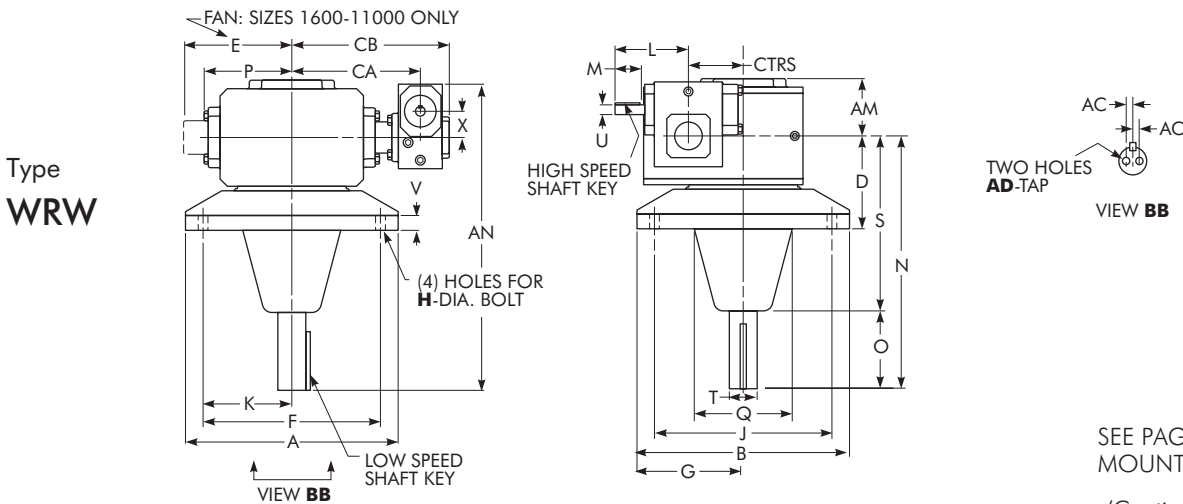
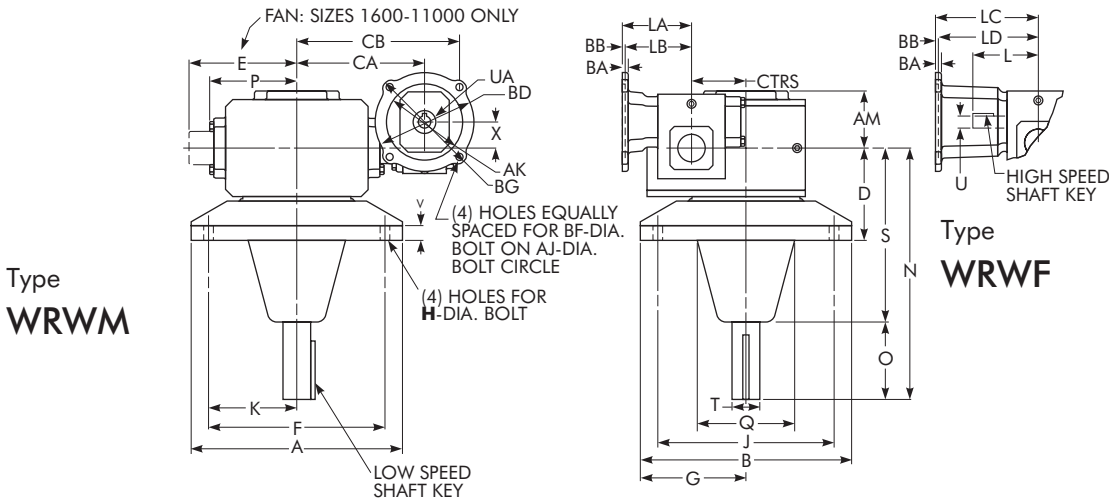

SEE PAGE 127 FOR MOTOR MOUNTING DIMENSIONS.

(Continued on next page)

DRIVE SIZE ★	CTRS	A	B	D	E	F	G	H	J	K	L	M •	N	O •	P	Q	S
1300	3.00	11.00	11.00	4.60	...	9.00	5.50	.56	9.00	4.50	4.35	1.76	14.38	4.96	4.84	5.12	9.42
1325	3.25	12.50	12.50	5.52	...	10.50	6.25	.56	10.50	5.25	4.35	1.76	15.00	4.63	5.02	5.75	10.37
1425	4.25	14.00	14.00	5.74	...	12.00	7.00	.69	12.00	6.00	4.82	1.76	16.50	5.91	6.10	6.75	10.59
1525	5.25	16.00	16.00	6.00	...	14.00	8.00	.81	14.00	7.00	6.07	2.38	16.50	5.62	7.50	8.00	10.88
1600	6.00	19.50	19.50	7.00	10.24	17.00	9.75	.88	17.00	8.50	6.76	2.38	22.50	7.63	...	9.50	14.87
1700	7.00	22.00	22.00	8.50	10.63	19.00	11.00	1.13	19.00	9.50	6.76	2.38	24.00	7.63	...	10.75	16.37
1800	8.00	28.00	28.00	10.00	11.93	24.00	14.00	1.31	24.00	12.00	9.57	3.47	27.06	9.25	...	13.75	17.81
11000	10.00	32.00	32.00	12.50	14.34	28.00	16.00	1.31	28.00	14.00	10.88	3.38	29.50	9.43	...	17.00	20.07

(See Page 5 for footnotes.)

**Note:**

**Omnibox Extended Output Shaft Drivers**

feature mounting and output shaft dimensions which are interchangeable with major competition:

Omnibox Size	Falk Center Distance	Competitive Size Center Distance
<b>1300</b>	3.000"	3.0"
<b>1325</b>	3.250"	3.5"
<b>1425</b>	4.250"	4.0"
<b>1525</b>	5.250"	5.0"
<b>1600</b>	6.000"	6.0"
<b>1700</b>	7.000"	7.0"
<b>1800</b>	8.000"	9.0"
<b>11000</b>	10.000"	11.0"

(Continued from preceding page)

DRIVE SIZE ★	Low Speed Shaft		High Speed Shaft		V	X	AC	AD	AM	AN	CA	CB	Approx. Wt – lb		
	T	Key	U	Key									WRWM	WRWF	WRW
	-.0005 -.0015		-.0005 -.0015												
<b>1300</b>	1.4380	.375 x .375 x 3.88	.6250	.188 x .188 x 1.50	.78	1.54	.375	.31-18 UNC X 1.00	3.15	17.85	7.86	10.06	123	128	121
<b>1325</b>	1.6250	.375 x .375 x 3.69	.6250	.188 x .188 x 1.50	.88	1.54	.375	.31-18 UNC X 1.00	3.40	18.47	8.05	10.25	125	130	123
<b>1425</b>	1.6880	.375 x .375 x 4.68	.6250	.188 x .188 x 1.50	1.00	2.06	.500	.38-16 UNC X 1.00	3.62	20.59	9.18	11.57	196	200	193
<b>1525</b>	2.1880	.500 x .500 x 4.63	.7500	.188 x .188 x 1.75	1.25	2.63	.750	.38-16 UNC X 1.00	4.28	21.56	11.57	14.47	322	323	314
<b>1600</b>	2.4380	.625 x .625 x 6.50	.8750	.188 x .188 x 1.75	1.50	3.25	.750	.38-16 UNC X 1.00	5.28	28.38	13.30	16.70	446	457	442
<b>1700</b>	2.9370	.750 x .750 x 6.44	.8750	.188 x .188 x 1.75	1.75	3.25	1.000	.38-16 UNC X 1.00	6.06	29.88	12.96	16.90	647	658	643
<b>1800</b>	3.4380	.875 x .875 x 8.00	1.2500	.250 x .250 x 2.88	2.00	4.25	1.062	.62-11 UNC X 1.50	6.22	34.00	13.94	18.19	930	938	920
<b>11000</b>	3.9380	1.000 x 1.000 x 7.75	1.2500	.250 x .250 x 3.00	2.25	5.25	1.188	.62-11 UNC X 1.50	7.94	38.38	17.05	22.30	1431	1438	1406

---

# Assemblies \*

Reverse all arrows for opposite rotation of high speed shaft.

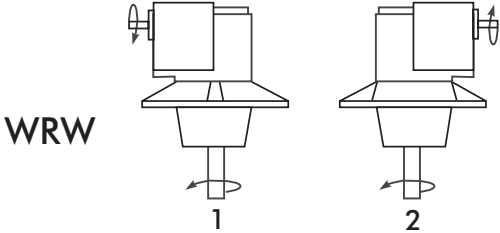
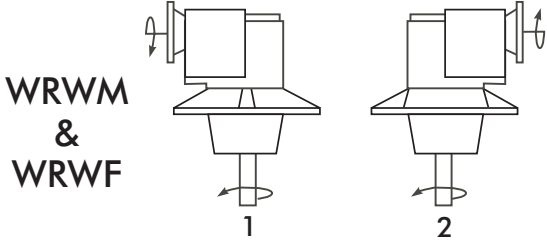

(See Page 5 for footnotes.)

# Motor Data

## NEMA Motor Flange Face Locations — Inches

DRIVE SIZE	56C/140TC		180TC		210TC		250TC	
	LA	LC	LB	LD	LB	LD	LB	LD
1300	3.99	6.60	...	...	...	...	...	...
1325	3.99	6.60	...	...	...	...	...	...
1425	4.46	7.07	...	...	...	...	...	...
1525	5.19	8.32	5.62	9.32	...	9.32	...	...
1600	5.88	9.01	6.31	10.01	6.75	10.01	...	...
1700	5.88	9.01	6.31	10.01	6.75	10.01	...	...
1800	6.45	11.81	7.21	12.90	7.21	12.90	7.77	13.46
11000	7.85	13.21	8.61	14.30	8.61	14.30	9.17	14.86

## NEMA Motor Mounting Dimensions — Inches

FRAME SIZE	AJ	AK	BA	BB	BD	BF	BG	UA	Keyway
56C	5.88	4.50	.38	...	5.88	.41	6.64	.625	.1875 x .0938
140TC	5.88	4.50	.38	...	5.88	.41	6.64	.875	.1875 x .0938
180TC	7.25	8.50	...	.50	9.00	.53	...	1.125	.2500 x .1250
210TC	7.25	8.50	...	.50	9.00	.53	...	1.375	.3125 x .1562
250TC	7.25	8.50	...	.50	9.00	.53	...	1.625	.3750 x .1875

## IEC B5 & B3/B5 Motor Flange Dimensions \* — Inches

DRIVE SIZE	D63D	D71D	D80D	D90D	D100LD/D112MD	D132D
	LA	LA	LA	LA	LA	LA
1300	3.15	3.18	3.42	...	...	...
1325	3.15	3.18	3.42	...	...	...
1425	3.62	3.65	3.89	...	...	...
1525	...	4.28	4.90	4.90	5.30	...
1600	...	4.97	5.59	5.59	5.99	...
1700	...	4.97	5.59	5.59	5.99	...
1800	...	...	...	6.38	6.39	7.17
11000	...	...	...	7.78	7.78	8.57

## IEC B5 & B3/B5 Metric Motor Mounting Dimensions — Millimeters

FRAME SIZE	AJ	AK	BA	BD	BF	BG	UA	Keyway
D63D	115	95	117	10	M8 x 1.25	131	11	4 x 2.0
D71D	130	110	132	11	M8 x 1.25	146	14	5 x 2.5
D80D	165	130	165	15	M10 x 1.50	184	19	6 x 3.0
D90D	165	130	165	15	M10 x 1.50	184	24	8 x 3.5
D100LD/D112MD	215	180	216	18	M12 x 1.75	237	28	8 x 3.5
D132D	265	230	267	18	M12 x 1.75	290	38	10 x 4.0

(See Page 5 for footnotes.)

# Double Reduction/Helical-Worm/Extended Output Shaft

Dimensions — Inches

Type  
**WRHM**

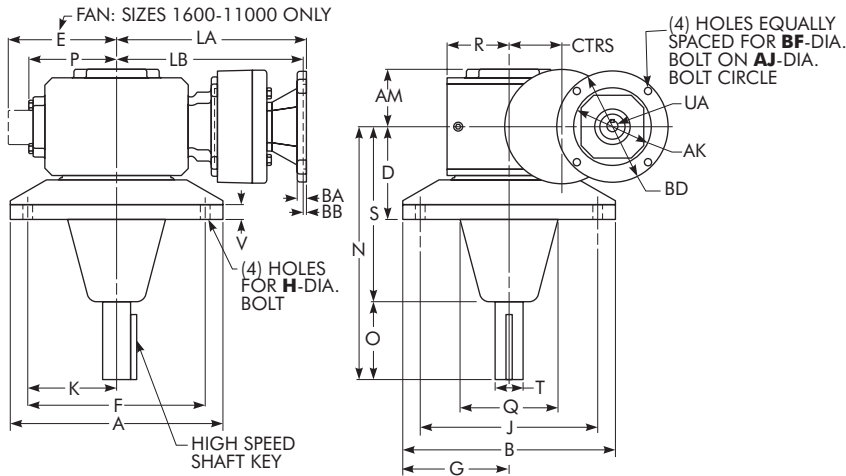

Type  
**WRH**

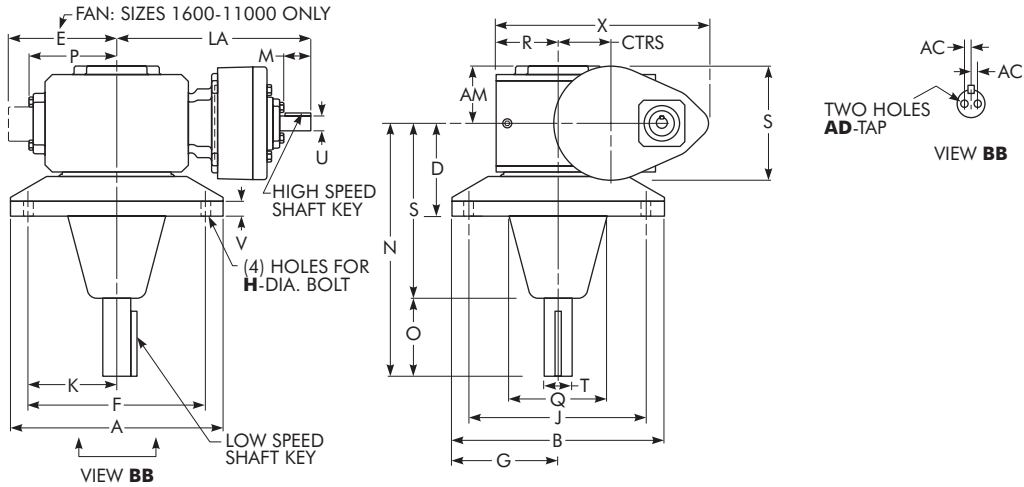

DRIVE SIZE ★	CTRS	A	B	D	E	F	G	H	J	K	L	M •	N	O •	P	Q	R	S
1300	3.00	11.00	11.00	4.60	...	9.00	5.50	.56	9.00	4.50	10.94	1.48	14.38	4.96	4.84	5.12	3.25	9.42
1325	3.25	12.50	12.50	5.52	...	10.50	6.25	.56	10.50	5.25	11.13	1.48	15.00	4.63	5.02	5.75	3.50	10.37
1425	4.25	14.00	14.00	5.74	...	12.00	7.00	.69	12.00	6.00	14.97	1.96	16.50	5.91	6.10	6.75	4.44	10.59
1525	5.25	16.00	16.00	6.00	...	14.00	8.00	.81	14.00	7.00	16.37	1.96	16.50	5.62	7.50	8.00	5.12	10.88
1600	6.00	19.50	19.50	7.00	10.24	17.00	9.75	.88	17.00	8.50	17.09	1.96	22.50	7.63	...	9.50	6.50	14.87
1700	7.00	22.00	22.00	8.50	10.63	19.00	11.00	1.13	19.00	9.50	19.68	2.50	24.00	7.63	...	10.75	7.59	16.37
1800	8.00	28.00	28.00	10.00	11.93	24.00	14.00	1.31	24.00	12.00	21.30	3.00	27.06	9.25	...	13.75	8.86	17.81
11000	10.00	32.00	32.00	12.50	14.34	28.00	16.00	1.31	28.00	14.00	25.78	3.50	29.50	9.43	...	17.00	10.36	20.07

DRIVE SIZE ★	Low Speed Shaft		High Speed Shaft		V	X	AC	AD	AM	Approx. Wt – lb	
	T -.0005 -.0015	Key	U -.0005 -.0015	Key						WRHM	WRH
1300	1.4380	.375 x .375 x 3.88	.6250	.188 x .188 x 1.25	.78	12.16	.375	.31-18 UNCX 1.00	3.15	128	126
1325	1.6250	.375 x .375 x 3.69	.6250	.188 x .188 x 1.25	.88	12.66	.375	.31-18 UNCX 1.00	3.40	130	128
1425	1.6880	.375 x .375 x 4.68	.8750	.188 x .188 x 1.50	1.00	13.31	.500	.38-16 UNCX 1.00	3.62	214	210
1525	2.1880	.500 x .500 x 4.63	.8750	.188 x .188 x 1.50	1.25	14.99	.750	.38-16 UNCX 1.00	4.28	306	302
1600	2.4380	.625 x .625 x 6.50	.8750	.188 x .188 x 1.50	1.50	17.12	.750	.38-16 UNCX 1.00	5.28	414	410
1700	2.9375	.750 x .750 x 6.44	1.1250	.250 x .250 x 2.25	1.75	21.84	1.000	.38-16 UNCX 1.00	6.06	...	640
1800	3.4375	.875 x .875 x 8.00	1.3750	.312 x .312 x 2.75	2.00	25.93	1.062	.62-11 UNCX 1.50	6.22	...	925
11000	3.9375	1.00 x 1.00 x 7.75	1.5000	.375 x .375 x 3.25	2.25	31.35	1.188	.62-11 UNCX 1.50	7.94	...	1405

(See Page 5 for footnotes.)



# Assemblies \*

Reverse all arrows for opposite rotation of high speed shaft.

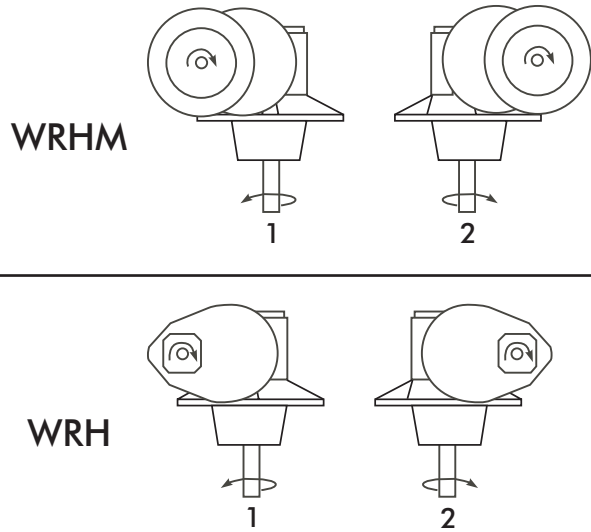

**Note:**

Omnibox Extended Output Shaft Drivers feature mounting and output shaft dimensions which are interchangeable with major competition:

Omnibox Size	Falk Center Distance	Competitive Size Center Distance
1300	3.000"	3.0"
1325	3.250"	3.5"
1425	4.250"	4.0"
1525	5.250"	5.0"
1600	6.000"	6.0"
1700	7.000"	7.0"
1800	8.000"	9.0"
11000	10.000"	11.0"

# Motor Data

## NEMA Motor Flange Face Locations — Inches

DRIVE SIZE	56C/140TC	180TC	210TC
	LA	LB	LB
1300	10.94	...	...
1325	11.13	...	...
1425	13.79	14.23	14.23
1525	15.19	15.63	15.63
1600	15.91	16.35	16.35

## NEMA Motor Mounting Dimensions — Inches

FRAME SIZE	AJ	AK	BA	BB	BD	BF	BG	UA	Keyway
56C	5.88	4.50	.50	...	6.50	.41	6.50	.625	.1875 x .0938
140TC	5.88	4.50	.50	...	6.50	.41	6.50	.875	.1875 x .0938
180TC	7.25	8.50	...	.56	9.00	.53	9.00	1.125	2500 x .1250
210TC	7.25	8.50	...	.56	9.00	.53	9.00	1.375	.3125 x .1562

(See Page 5 for footnotes.)

# Helical & Worm Primaries/Type HP & WP

- Increases Inventory & Application Flexibility.
- Choice of Ratios 2:1 through 60:1.
- Three Input Types:
  - Solid Input
  - Motorized Hollow Input
  - Motorized Solid Input/ Coupling
- Motor Frame

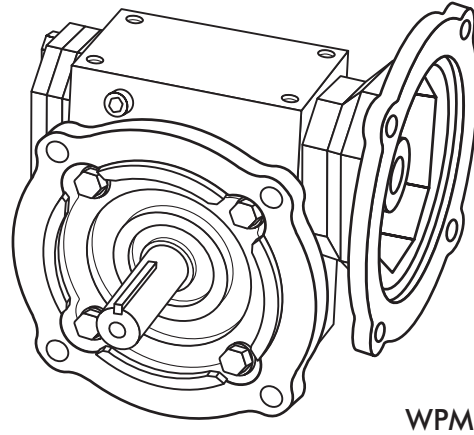
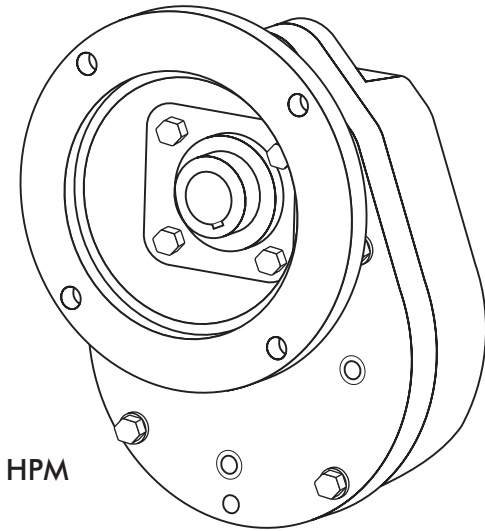

## Ratio Multipliers for Universal Mounting Between Any C-Face Motor & Drive

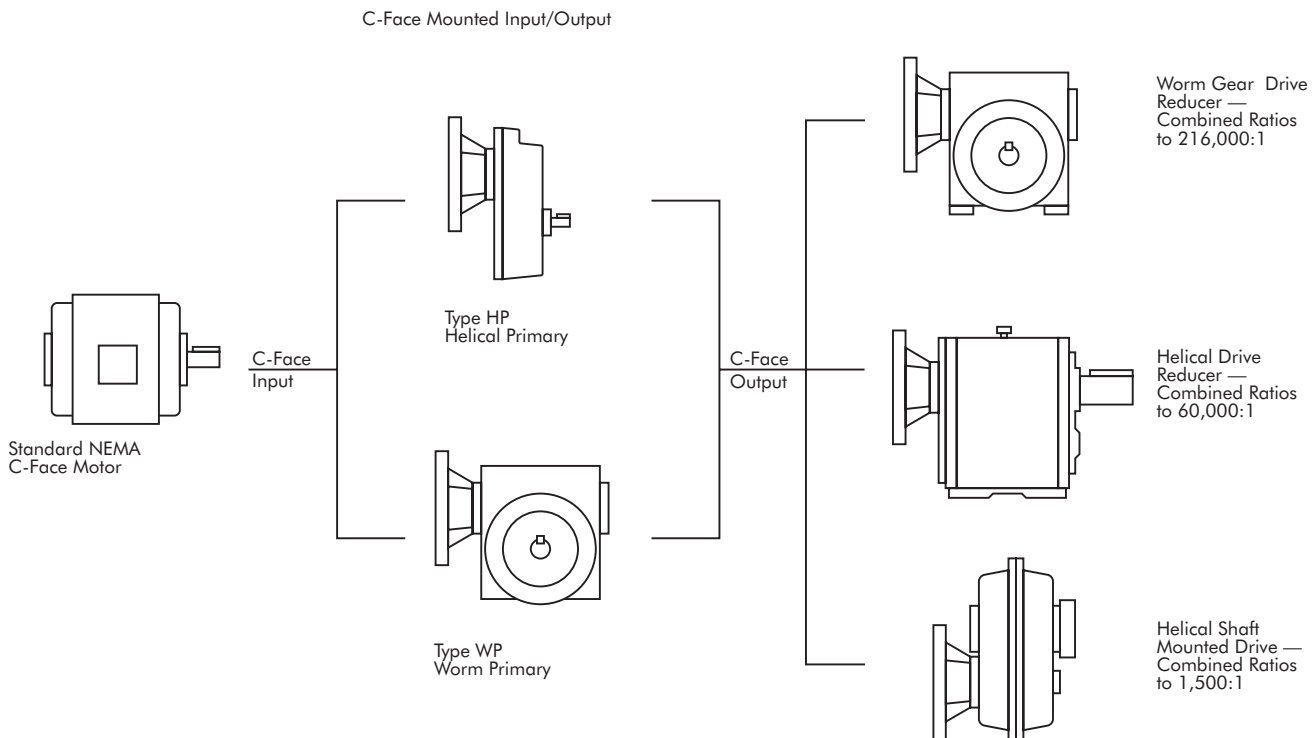

# Selection Procedure

1. Determine Service Factor (SF)
2. Determine Motor Horsepower (hp) Input rpm, Output rpm, & Overall Ratio

$$\text{Overall Ratio} = \frac{\text{Input RPM}}{\text{Output RPM}}$$

3. Calculate Equivalent Output Torque Rating

$$\frac{\text{HP} \times \text{SF} \times 6300}{\text{Output RPM}}$$

4. Select Secondary Size & Type.

$$\text{Input RPM} = \frac{\text{Motor RPM}}{\text{Primary Ratio}}$$

$$\text{Secondary Ratio} = \frac{\text{Overall Ratio}}{\text{Primary Ratio}}$$

Select the Secondary Size & Ratio at the Corresponding Input/Output rpm with an Output Torque Rating that Exceeds the Equivalent Output Torque

5. Check Overhung or Thrust Loads.
6. Select the Primary Size & Type.  
Select the Primary Size & Ratio at the Corresponding Input/Output rpm with an Equivalent H.P. Rating (SF x Motor hp) that Exceeds the drive Input hp Rating.  
Match the Primary C-Face Output to the Secondary C-Face Input Flange.  
NOTE: The Output Torque Delivered is a Function of the Overall Drive Combined Efficiency!
7. Check Drive Dimensions.

## EXAMPLE:

Select a Drive for a Uniformly Loaded, Hollow Shaft Connected Belt Conveyor with a Headshaft Speed of 17.5 rpm, Operating 16 Hours Per Day, Driven by a 1750 rpm, 3 hp Electric Motor.

1. Service Factor is 1.25 from Page 11.
2. Motor Horsepower is 3 hp.
3. Drive Output Speed is 17.5 rpm,  
$$\frac{1750 \text{ rpm Input}}{17.5 \text{ rpm Output}} = 100:1 \text{ Overall Ratio}$$

NOTE: When Using a Worm Gear Secondary, the Selection can be made from the WBW Worm-Worm Quick Selection Tables. After making the selection, substitute the WPM Worm Primary of the same size and ratio for the WBW standard primary, onto the secondary drive with a C-Face input sized to match the primary output.

4. Equivalent Output Torque Rating:  
$$\frac{3 \text{ HP} \times 1.25 \text{ SF} \times 63,000}{17.5 \text{ rpm}} = 3,500 \text{ in-lb}$$
5. Select Secondary Size & Type:  
$$\frac{100:1 \text{ Overall Ratio}}{\text{Primary Ratio}} = \text{Secondary Ratio}$$

$$\frac{1750 \text{ RPM}}{5:1 \text{ Primary Ratio}} = 350 \text{ RPM Secondary Input Speed}$$

Select the Secondary Size at 350 rpm input with 20:1 ratio and an output torque rating equal to or greater than 13,500 in-lb.

6. No Overhung or Thrust Loads.
7. Select Primary Size & Type: Equivalent hp rating = 3hp x 1.25 SF = 3.75 Ehp. Select the primary size at 1750 rpm input and 20:1 ratio with an input hp rating greater than 3.75 hp.
8. Check Drive Dimensions.

# Horsepower & Torque Ratings/Helical Primaries

Input Speed: 1750 rpm

(All capacity ratings based on AGMA Standards with a service factor of 1.0)

Primary Size	1				2				3											
Output Flange	56C				56C				140TC				180TC				210TC			
Nominal Ratio	Input hp	Output rpm	Output Torque (lb-in)	Max L.S. OHL (lb)	Input hp	Output rpm	Output Torque (lb-in)	Max L.S. OHL (lb)	Input hp	Output rpm	Output Torque (lb-in)	Max L.S. OHL (lb)	Input hp	Output rpm	Output Torque (lb-in)	Max L.S. OHL (lb)	Input hp	Output rpm	Output Torque (lb-in)	Max L.S. OHL (lb)
2:1	1.80	1.76	127	313	5.76	5.65	407	372	12.00	11.70	843	480	13.34	13.01	937	999	13.34	13.01	937	650
3:1	1.50	1.46	152	313	3.83	3.76	407	372	8.30	8.10	876	480	10.84	10.62	1121	999	10.84	10.62	1121	650
4:1	1.25	1.22	179	313	2.87	2.82	407	372	6.00	5.90	851	480	7.39	7.24	1040	999	7.39	7.24	1040	650
5:1	1.00	.98	177	313	2.30	2.26	407	372	5.30	5.20	931	480	6.10	5.98	1076	999	6.10	5.98	1076	650
Weight HPS	19				22				45											
Weight HPM	19				22				45											
Weight HPF	26				29				54											
Oil Capacity	10 oz				14 oz				14 oz											
Use as Primary on Omnibox Sizes:	1133-1206				1238-1325				1425-1600											
Exact Ratio	2.000 2.882 4.077 5.000				2.000 2.931 3.957 5.000				2.000 2.931 3.975 5.000											

## Nameplate Identification

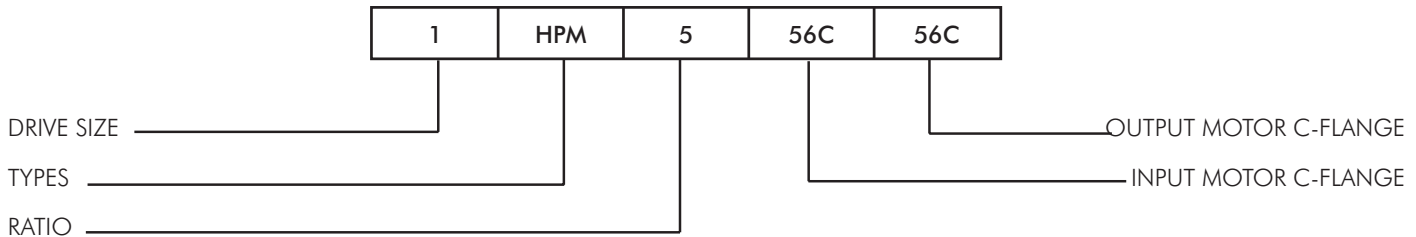

### Drive Size

1,2,3

### Types

HPM — Motorized Hollow Input  
 HPF — Motorized Solid Input/Coupling  
 HPS — Solid Input

### Ratio

2,3,4,5

### Input Motor C-Flange

48C to 210 TC

### Output Motor C-Flange

56C to 210 TC

# Horsepower and Torque Ratings/Worm Primaries

Input Speed: 1750 rpm

(For other input speed ratings refer to the worm drive rating section for single reduction drives. For all other capacity ratings based on AGMA Standards with a service factor of 1.0)

SIZE		1133			1175			1238		
Exact Ratio	Input hp	Output hp	Output Torque (lb-in)	Input hp	Output hp	Output Torque (lb-in)	Input hp	Output hp	Output Torque (lb-in)	
5	1.058	.966	172	1.073	1.560	281	3.889	3.626	653	
7.5	.871	.778	210	1.667	1.516	409	3.466	3.195	863	
10	.733	.634	228	1.368	1.227	442	3.083	2.809	1011	
15	.551	.452	244	1.026	.876	473	2.303	2.028	1095	
20	.437	.344	248	.814	.677	287	1.828	1.557	1121	
25	.375	.279	251	.665	.537	483	1.510	1.249	1124	
30	.328	.232	251	.597	.451	487	1.319	1.049	1133	
40	.260	.171	247	.469	.338	486	1.040	0.778	1121	
50	.211	.131	237	.377	.258	465	.847	0.502	1084	
60	.181	.104	226	.317	.204	442	.674	0.466	1007	
Weight (lb)	WPS	17			25			48		
	WPM	19			26			56		
	WPF	24			32			62		

## Nameplate Identification

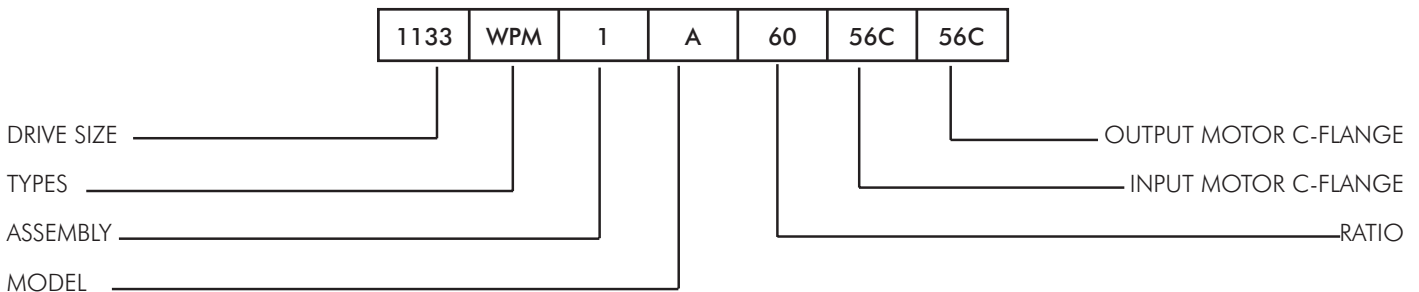

### Drive Size/Shaft Centers (In.)

1133 = 1.33  
 1175 = 1.75  
 1238 = 2.38

### Types

WPM — Flange Mounted Motorized Hollow Input  
 WPF — Flange Mounted Motorized Solid Input/Coupling  
 WPS — Solid Input

### Assembly

1 or 2

### Input Motor C-Flange

Refer to dimension pages

### Output Motor C-Flange

Refer to dimension pages

### Ratio

As shown above

# Helical Primary

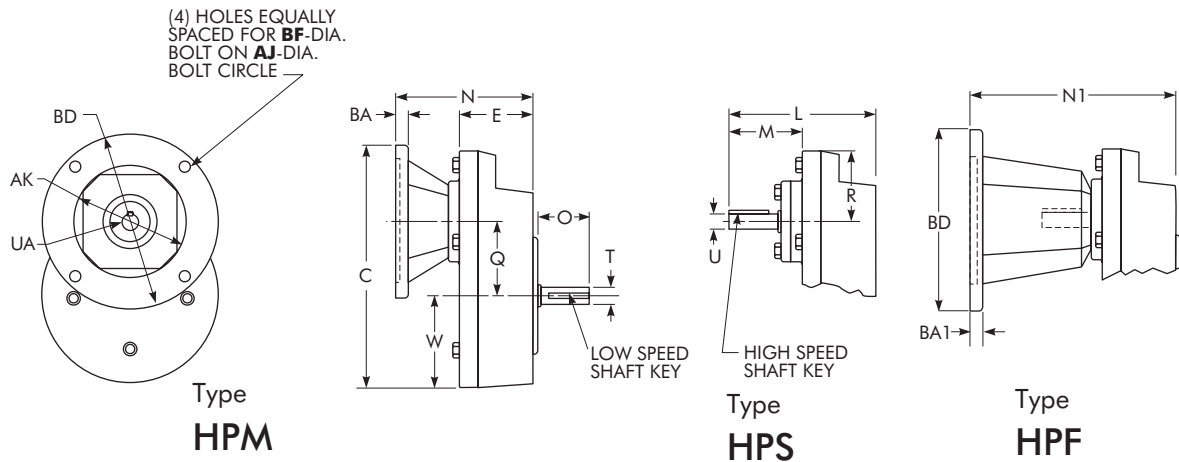

SIZE	Input-Output Frame	C	N	N1	O •	AJ	AK	BA	BA1	BD	BF ◊	Low Speed Shaft		High Speed Shaft		Hollow High Speed Shaft	
												T	Keyway	U	Keyway	UA	Keyway
1	56C	7.08	4.66	8.00	2.06	5.88	4.50	.50	.50	5.88	.406	.6250	.188 x .094 x 1.50	.5000	.125 x .062 x 1.25	.6250	.188 x .094
2	56C-56C	9.50	5.25	7.55	2.06	5.88	4.50	.50	.50	6.50	.410	.6250	.188 x .094 x 1.50	.6250	.188 x .094 x 1.25	.6250	.188 x .094
	56C-140TC	9.50	5.25	7.55	2.06	5.88	4.50	.50	.50	6.50	.410	.8750	.188 x .094 x 1.50	.6250	.188 x .094 x 1.25	.6250	.188 x .094
	140TC-56C	9.50	5.25	7.55	2.06	5.88	4.50	.50	.50	6.50	.410	.6250	.188 x .094 x 1.50	.6250	.188 x .094 x 1.25	.8750	.188 x .094
	140TC-140TC	9.50	5.25	7.55	2.06	5.88	4.50	.50	.50	6.50	.410	.8750	.188 x .094 x 1.50	.6250	.188 x .094 x 1.25	.8750	.188 x .094
3	56C-180TC	10.38	6.58	10.51	2.62	5.88	4.50	.50	.84	6.50	.410	1.1250	.250 x .125 x 1.80	.8750	.188 x .094 x 1.50	.6250	.188 x .094
	56C-210TC	10.38	6.58	10.51	3.12	5.88	4.50	.50	.84	6.50	.410	1.3750	.312 x .156 x 1.80	.8750	.188 x .094 x 1.50	.6250	.188 x .094
	140TC-180TC	10.38	6.58	10.51	2.62	5.88	4.50	.50	.84	6.50	.410	1.1250	.250 x .125 x 1.80	.8750	.188 x .094 x 1.50	.8750	.188 x .094
	140TC-210TC	10.38	6.58	10.51	3.12	5.88	4.50	.50	.84	6.50	.410	1.3750	.312 x .156 x 1.80	.8750	.188 x .094 x 1.50	.8750	.188 x .094
	180TC-180TC	11.63	...	...	2.62	7.25	8.50	...	...	9.00	.530	1.1250	.250 x .125 x 1.80	.8750	.188 x .094 x 1.50	1.1250	.250 x .125
	180TC-210TC	11.63	...	...	3.12	7.25	8.50	...	...	9.00	.530	1.3750	.312 x .156 x 1.80	.8750	.188 x .094 x 1.50	1.1250	.250 x .125
	210TC-180TC	11.63	...	...	2.62	7.25	8.50	...	...	9.00	.530	1.1250	.250 x .125 x 1.80	.8750	.188 x .094 x 1.50	1.3750	.312 x .156
	210TC-210TC	11.63	...	...	3.12	7.25	8.50	...	...	9.00	.530	1.3750	.312 x .156 x 1.80	.8750	.188 x .094 x 1.50	1.3750	.312 x .156

SIZE	E	L	M •	Q	R	W
1	2.62	5.56	1.58	1.68	1.37	2.46
2	2.83	5.25	1.48	2.88	2.73	3.37
3	3.44	7.76	1.96	2.88	1.75	4.25

(See Page 5 for footnotes.)

# Mounting Positions

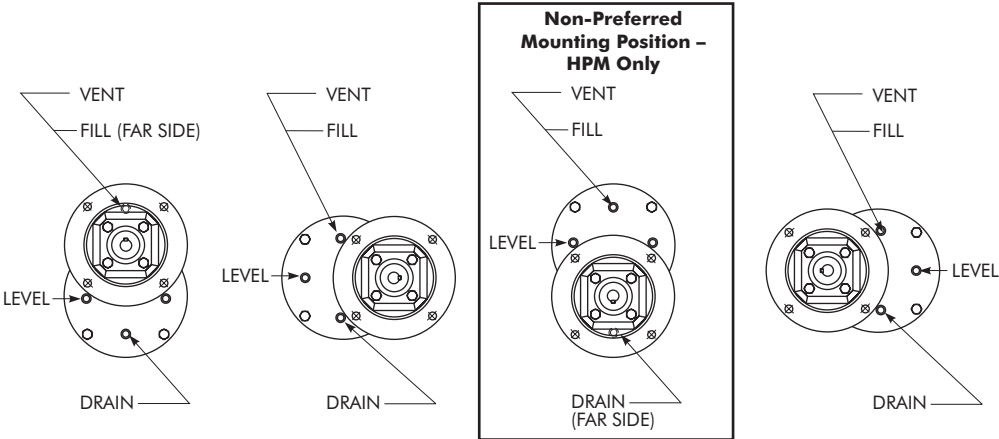

# Worm Primaries

Type  
WPM

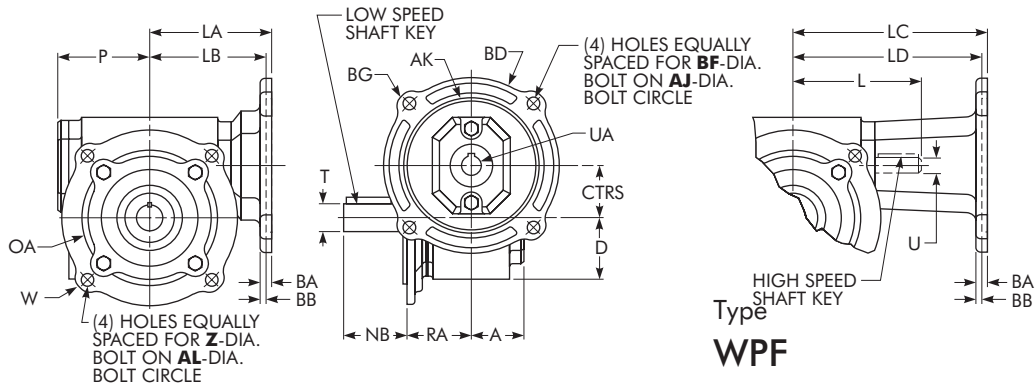

Type  
WPS

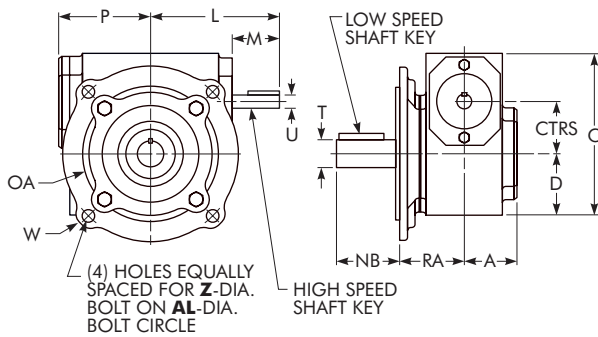

PRIMARY SIZE *	Motor Flange Output	CTRS	A	C	D	L	M	OA	P	RA
1133	56C	1.333	1.84	4.66	1.72	3.82	1.76	4.500	2.61	2.94
1175	140TC	1.750	1.81	5.44	2.06	4.45	1.76	4.500	3.24	2.15
1238	180TC	2.375	1.97	6.88	2.69	5.51	2.38	8.500	3.77	3.97

PRIMARY SIZE *	Motor Flange Output	Low Speed Shaft		High Speed Shaft		W	Z	AL	NB	Approx. Wt - lb		
		T -.0005 -.0015	Key	U -.0005 -.0015	Key					WPM	WPF	WPS
1133	56C	.6250	.188 x .188 x 1.44	.5000	.125 x .125 x 1.44	6.64	.3750-16	5.88	2.06	10	19	12
1175	140TC	.8750	.188 x .188 x 1.44	.6250	.188 x .188 x 1.50	6.63	.3750-16	5.88	2.58	13	23	16
1238	180TC	1.1250	.250 x .250 x 1.81	.7500	.188 x .188 x 1.75	9.00	.5000-13	7.25	3.14	22	30	25

(See Page 5 for footnotes.)



# Assemblies \*

Reverse all arrows for opposite rotation of high speed shaft.

WPM  
&  
WPF

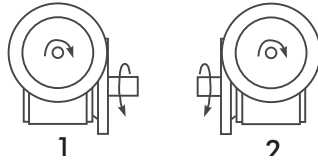

WPS

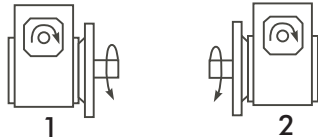

## Motor Data

### NEMA Motor Flange Face Locations — Inches

DRIVE	56C/140T		180TC		210TC
	LA	LC	LB	LD	LD
1133	3.46	6.07	...	...	...
1175	4.09	6.70	...	...	...
1238	4.63	7.76	5.06	8.76	8.76

### NEMA Motor Mounting Dimensions — Inches

FRAME SIZE	AJ	AK	BA	BB	BD	BF	BG	UA	Keyway
56C	5.88	4.50	.38	...	5.88	.41	6.64	.625	.1875 x .0938
140TC	5.88	4.50	.38	...	5.88	.41	6.64	.875	.1875 x .0938
180TC	7.25	8.50	...	.50	9.00	.53	...	1.125	.2500 x .1250
210TC	7.25	8.50	...	.50	9.00	.53	...	1.375	.3125 x .1562

### IEC B5 & B3/B5 Motor Flange Dimensions \* — Inches

DRIVE SIZE	D63D	D71D	D80D
	LA	LA	LA
1133	2.62	2.65	2.89
1175	3.25	3.28	3.52
1238	...	3.72	4.34

### IEC B5 & B3/B5 Metric Motor Mounting Dimensions — Millimeters

FRAME SIZE	AJ	AK	BA	BD	BF	BG	UA	Keyway
D63D	115	95	10	117	131	M8 x 1.25	11	4 x 2.0
D71D	130	110	11	132	146	M8 x 1.25	14	5 x 2.5
D80D	165	130	15	165	184	M10 x 1.50	19	6 x 3.0

(See Page 5 for footnotes.)

# Accessories

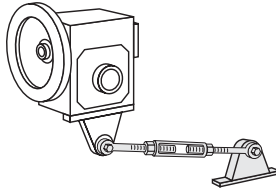

**Tie Rod (TRK)**

DRIVE SIZE	Number
1133	TRK 1133
1154	TRK 1154
1175	TRK 1175
1206	TRK 1206
1238	TRK 1238
1262	TRK 1262
1300	TRK 1300
1325	TRK 1325
1425	TRK 1425
1525	TRK 1525
1600	TRK 1600

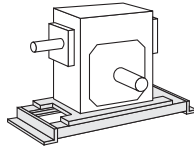

**Slide Base (SB)**

DRIVE SIZE	Number
1133	SB 1133
1154	SB 1154
1175	SB 1175
1206	SB 1206
1238	SB 1238
1262	SB 1262
1300	SB 1300
1325	SB 1325

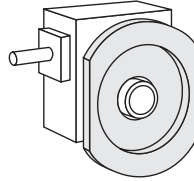

**Hollow Output Flange Kit (OFK)**

DRIVE SIZE	Number
1133	OFK 1133
1154	OFK 1154
1175	OFK 1175
1206	OFK 1206
1238	OFK 1238
1262	OFK 1262
1300	OFK 1300
1325	OFK 1325
1425	OFK 1425
1525	OFK 1525
1600	OFK 1600
1700	OFK 1700<
1800	OFK 1800<
11000	OFK 11000<

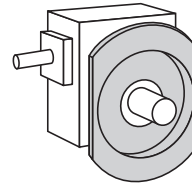

**Solid Output Flange Kit (OFK)**

DRIVE SIZE	Number
1133	OFK 1133
1154	OFK 1154
1175	OFK 1175
1206	OFK 1206
1238	✦
1262	✦
1300	✦
1325	✦
1425	✦
1525	✦
1600	OFK 1600
1700	✦
1800	✦
11000	✦

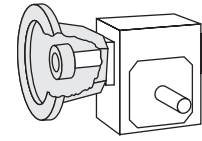

**Motor Flange & Coupling (MFK)**

DRIVE SIZE	Number
1133	MFK 1133-48 MFK 1133-56 MFK 1133-140
1154	MFK 1154-48 MFK 1154-56 MFK 1154-140
1175	MFK 1175-48 MFK 1175-56 MFK 1175-140
1206	MFK 1206-48 MFK 1206-56 MFK 1206-140
1238	MFK 1238-56 MFK 1238-140 MFK 1238-180 MFK 1238-210
1262	MFK 1262-56 MFK 1262-140 MFK 1262-180 MFK 1262-210
1300	MFK 1300-56 MFK 1300-140 MFK 1300-180 MFK 1300-180
1325	MFK 1325-56 MFK 1325-140 MFK 1325-180 MFK 1325-210
1425	MFK 1425-56 MFK 1425-140 MFK 1425-180 MFK 1425-210 MFK 1425-250
1525	MFK 1525-56 MFK 1525-140 MFK 1525-180 MFK 1525-210 MFK 1525-250
1600	MFK 1600-180 MFK 1600-210 MFK 1600-250
1700	MFK 1700-180 MFK 1700-210 MFK 1700-250
1800	MFK 1800-210 MFK 1800-250

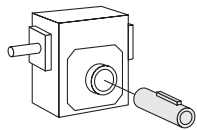

**Hollow Output Shaft Bushing Kit (HOSB)**

## Bushings

DRIVE SIZE	BORE DIA	Driven Shaft Keyway	Number
1175	.750	.188 x .094	HOSB-075
	.875	.188 x .094	HOSB-087
1206/1238	1.000	.250 x .125	HOSB-100
	1.125	.250 x .125	HOSB-112
	1.188	.250 x .125	HOSB-118
	1.250	.250 x .125	HOSB-125
1262	1.000	.250 x .125	HOSB-100
	1.125	.250 x .125	HOSB-112
	1.188	.250 x .125	HOSB-118
	1.250	.250 x .125	HOSB-125
1300	1.438	.375 x .188	HOSB-143
	1.500	.375 x .188	HOSB-150
1325	1.250	.250 x .125	HOSB-125
	1.438	.375 x .188	HOSB-143
	1.500	.375 x .188	HOSB-150
	1.750	.375 x .188	HOSB-175
1425	1.500	.375 x .188	HOSB-150
	1.938	.500 x .250	HOSB-193
	2.000	.500 x .250	HOSB-200
	1525/1600	2.000	.500 x .250
2.188		.500 x .250	HOSB-218
2.250		.500 x .250	HOSB-225
2.438		.625 x .313	HOSB-243
2.500		.625 x .313	HOSB-250
2.938		.750 x .375	HOSB-293
1700	2.438	.625 x .313	HOSB-243
	2.500	.625 x .313	HOSB-250
	2.688	.625 x .313	HOSB-268
	2.938	.750 x .375	HOSB-293
	3.000	.750 x .375	HOSB-300
1800	3.438	.875 x .438	HOSB-343
	3.938	1.00 x .500	HOSB-393
	4.188	1.00 x .500	HOSB-418
11000	3.438	.875 x .438	HOSB-343
	3.938	1.00 x .500	HOSB-393
	4.438	1.00 x .500	HOSB-443
	4.938	1.25 x .625	HOSB-493

(See Page 5 for footnotes.)

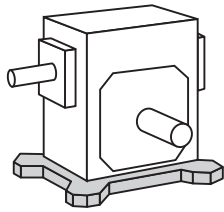

### Horizontal Output Foot Kit (HOFK)

DRIVE SIZE	Number
1133	HOFK 1133
1154	HOFK 1154
1175	HOFK 1175
1206	HOFK 1206
1238	HOFK 1238
1262	HOFK 1262
1300	HOFK 1300
1325	HOFK 1325
1425	HOFK 1425
1525	HOFK 1525
1600	HOFK 1600
1700	HOFK 1700
1800	HOFK 1800
11000	HOFK 11000

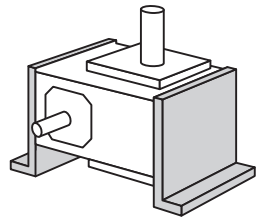

### Vertical Output Foot Kit (VOFK)

DRIVE SIZE	Number
1133	VOFK 1133
1154	VOFK 1154
1175	VOFK 1175
1206	VOFK 1206
1238	VOFK 1238
1262	VOFK 1262
1300	VOFK 1300
1325	VOFK 1325
1425	VOFK 1425
1525	VOFK 1525
1600	VOFK 1600
1700	VOFK 1700
1800	VOFK 1800
11000	VOFK 11000

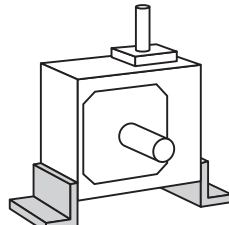

### Vertical Input Foot Kit (VIFK)

DRIVE SIZE	Number
1133	VIFK 1133
1154	VIFK 1154
1175	VIFK 1175
1206	VIFK 1206
1238	VIFK 1238
1262	VIFK 1262
1300	VIFK 1300
1325	VIFK 1325
1425	VIFK 1425
1525	VIFK 1525

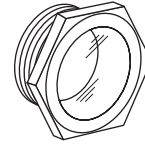

### Oil Level Sight Gauge (OLSG)

DRIVE SIZE	Number
1133	OLSG 1133
1154	OLSG 1154
1175	OLSG 1175
1206	OLSG 1206
1238	OLSG 1238
1262	OLSG 1262
1300	OLSG 1300
1325	OLSG 1325
1425	OLSG 1425
1525	OLSG 1525
1600	OLSG 1600
1700	OLSG 1700
1800	OLSG 1800
11000	OLSG 11000

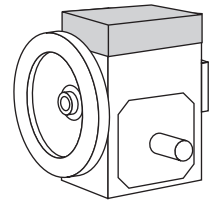

### Riser Block (RB)

DRIVE SIZE	Number	Height (inches)
1133	...	...
1154	RB 1154	2.00
1175	RB 1175	2.00
1206	RB 1206	2.00
1238	RB 1238	2.00
1262	RB 1262	1.50
1300	RB 1300	2.13
1325	RB 1325	2.13
1425	RB 1425	2.13
1525	RB 1525	1.25
1600	...	...
1700	...	...
1800	...	...
11000	...	...

### Bored to Size L.S. Shaft

DRIVE SIZE	BORE DIA	Driven Shaft Keyway
1133	.625	.188 x .094
1154	.625	.188 x .094
1175	.625	.188 x .094
	.688	.188 x .094
	.750	.188 x .094
	.875	.188 x .094
1.000	.250 x .125	
1206/ 1238	1.000	.250 x .125
	1.125	.250 x .125
	1.188	.250 x .125
	1.250	.250 x .125
1.438	.375 x .188	
1262	1.000	.250 x .125
	1.125	.250 x .125
	1.188	.250 x .125
	1.250	.250 x .125
1.438	.375 x .188	
1300	1.188	.250 x .125
	1.250	.250 x .125
	1.438	.375 x .188
	1.500	.375 x .188
	1.625	.375 x .188
	1.688	.375 x .188
1325	1.750	.375 x .188
	1.938	.500 x .250
	1.188	.250 x .125
	1.250	.250 x .125
	1.438	.375 x .188
	1.500	.375 x .188
1.625	.375 x .188	
1.688	.375 x .188	
1.750	.375 x .188	
1.938	.500 x .250	

### Bored to Size L.S. Shaft (continued)

DRIVE SIZE	BORE DIA	Driven Shaft Keyway
1425	1.438	.375 x .188
	1.500	.375 x .188
	1.625	.375 x .188
	1.688	.375 x .188
	1.750	.375 x .188
	1.875	.500 x .250
	1.938	.500 x .250
	2.000	.500 x .250
1525	2.188	.500 x .250
	2.000	.500 x .250
	2.188	.500 x .250
	2.250	.500 x .250
	2.438	.625 x .313
	2.500	.625 x .313
	2.688	.625 x .313
	2.938	.750 x .375
	3.000	.750 x .375
	3.188	.750 x .375
3.438	.875 x .438	

# Additional Product Offerings for Special Applications

## Pressure Equalization System

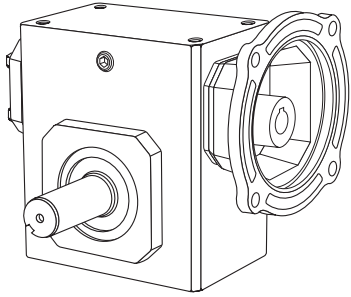

- Where a sealed drive is needed.
- Keeps internal pressure down, lubricant in the box and contaminants out.
- Very low maintenance.
- Synthetic lubricant is standard.
- Viton7 Seals are standard.

## Stainless Steel

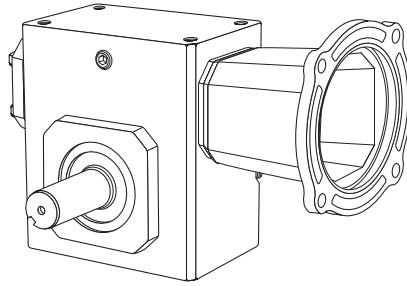

- Suitable for harsh environments and special wash-down applications.
- Housings and covers are 304 grade cast stainless steel, output shafts are 303 grade stainless steel.
- External hardware is all stainless steel.
- Includes Pressure Equalizing System
- Viton7 seals are standards.
- Synthetic Lube.
- Stainless Steel Nameplate.

## BISSC Certified

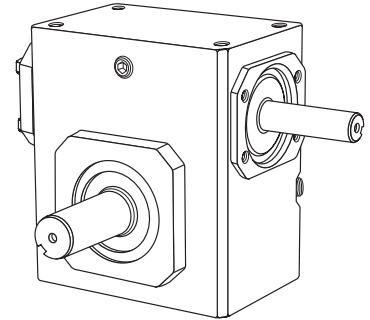

- Suitable for wash-down applications and are furnished with USDA approved paint, nickel plated shafts, Viton7 seals, smooth exterior surfaces, solid head plugs and bolts for easy cleaning, and a stainless steel nameplate.
- Certifications:
  - Baking Industry Sanitation Standard Committee (BISSC) Certified
  - Standard Lubrications us USDA h-2 Approved

## Size and Type Availability of Pressure Equalization System

All Sizes from 1133W (1.33" CD) through 1525W (5.25" CD).

All Types of Single Reductions and Double Reductions Worm-Worm Styles.

## Size and Type Availability of Stainless Steel

DRIVE SIZE	Single Reduction					Double Reduction		
	WBF	WBM		WBQM		WBWF	WBWM	WBWQM
	56/140	56/140	180/210	56/140	180/210	56/140	56/140	56/140
1133	X	X						
1154	X	X						
1238	.	X	X	X	X	X	X	X
1325	.	X	X	X	X	X	X	X

## Size and Type Availability of BISSC Certified

Sizes 1133- 1600 are available in the following types:

WB, WBF, WBM, WBM, WO, WOF, WOM, WU, WUF, WUM, WX, WXF, WXM, WJ, WJF, WJM, WBQ, WBQF, and WBQM

Sizes 1700 -11000 are available in the following types:

WB, WO, WU, WX, and WBQ

# Engineering Data- Bolt Circle

Dimensions — Inches

## Output Covers

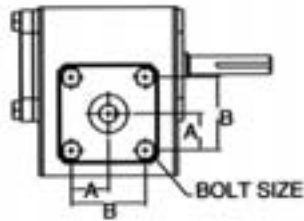

SIZE 1133-1525

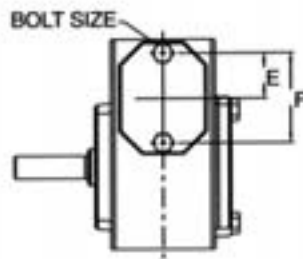

SIZE 1133

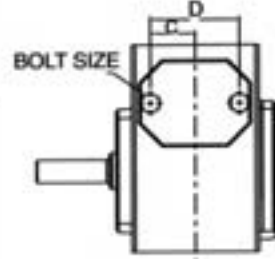

SIZE 1154-1206

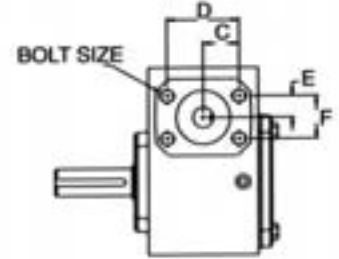

SIZE 1238-1800

## Output Cover

DRIVE SIZE	A	B	Bolt Size
1133	1.016	2.033	.312-18
1154	1.016	2.033	.312-18
1175	1.480	2.961	.312-18
1206	1.480	2.961	.312-18
1238	1.856	3.712	.312-18
1262	1.856	3.712	.312-18
1300	2.298	4.596	.375-16
1325	2.298	4.596	.375-16
1425	2.939	5.877	.438-14
1525	3.359	6.717	.438-14
1600	Consult Factory		.500-13
1700	Consult Factory		.500-13
1800	Consult Factory		.500-13
11000	Consult Factory		.500-13

## Input Cover

DRIVE SIZE	C	D	E	F	Bolt Size
1133	1.219	2.438	...	...	.312-18
1154	1.219	2.438	...	...	.312-18
1175	1.219	2.438	...	...	.312-18
1206	1.219	2.438	...	...	.312-18
1238	1.313	2.625	0.781	1.562	.312-18
1262	1.313	2.625	0.781	1.562	.312-18
1300	1.313	2.625	0.781	1.562	.312-18
1325	1.313	2.625	0.781	1.562	.312-18
1425	1.600	3.200	1.050	2.100	.438-14
1525	1.600	3.200	1.050	2.100	.438-14
1600	1.370	2.740	1.370	2.740	.438-14
1700	2.033	2.033	2.033	2.033	.438-14
1800	2.121	2.121	2.121	2.121	.500-13
11000		Consult Factory			.625-11

# Omnibox Interchangeability

## Component Interchangeability of Gear Drives & Accessories 100W Series & 1000W Series i

100W Series	100	133	154	175	206	238	262	300	325	425	525	600	700	800	1000		
1000W Series	NA	1133	1154	1175	1206	1238	1262	1300	1325	1425	1525	1600	1700	1800	11000		
<b>WB</b>	●	YES †									YES						
<b>WBM =</b>		YES							NA								
<b>WBQ</b>		YES †									YES						
<b>WBQM =</b>		YES							NA								
<b>HOFK</b>		YES															
<b>VOFK</b>		YES															
<b>VIFK</b>		YES										NA					
<b>Tie Rod</b>		YES										NA					
<b>Slide Base</b>		YES									NA						
<b>Oil Sight Gauge</b>		YES															
<b>WWAK</b>		NO											NA				
<b>MFK</b>		NO										YES				NA	
<b>Coupling For MFK</b>		YES							NA								
<b>Output Flange</b>		NO										YES					
<b>Riser Blocks</b>		YES										NA					
<b>Bushings</b>		YES *										YES					
<b>Fans</b>		NA							NO				YES				
<b>Scoop Mount</b>																	
<b>Top Motor Mount</b>																	
<b>Drywell</b>																	
<b>ADDED 1000 SERIES FEATURES</b>																	
<b>Pressure Equalizing System</b>	NA	Refer to Product Catalog for Specific Feature Availability															
<b>Stainless Steel Drives</b>	NA	Refer to Product Catalog for Specific Feature Availability															

★ NA = Not Available

Yes = Item is interchangeable between 100 & 1000 Series Drives.

No = Item is not interchangeable between 100 & 1000 Series Drives.

● Item or Size is Discontinued for 1000 Series.

◆ Distance from the end of the Input Shaft to the Centerline of the Drive is shorter on the 1000 Series Omnibox. All other Critical Dimensions are the same.

\* 100 Series Bushings may be used in 1000 Series Drives provided the set screw holes are redrilled.

† Sizes 1700 and 1800 are Types WBF or WBQF.

---

# Non-Preferred Mounting Positions

The mounting positions noted below are not recommended due to the increased probability of leakage from high speed shafts seals. Assembly position options also apply to motor flange drives.

## Single Reduction

All Types of Worm Drives mounted in the Worm-Under position or where the drive is rotated so the High Speed Solid Shaft is pointing Vertically Down.

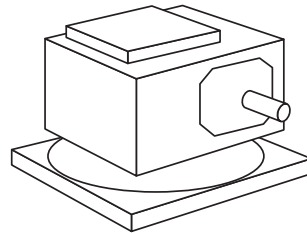
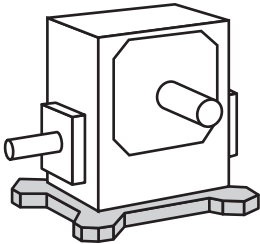

## Double Reduction/Worm-Worm

All Types of Worm Primaries where the primary is in the Worm-Under Position or where the Worm Primary is rotated so the High Speed Shaft is pointing vertically down.

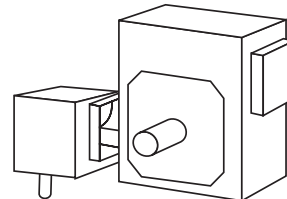
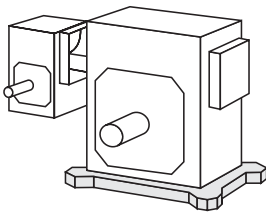

## Double Reduction/Helical Worm

All Types of Helical Primaries where the High Speed Shaft is in the six o'clock position (High Speed Shaft is beneath the Low Speed Shaft ) or where the Helical Primary is positioned with the High Speed Shaft pointing vertically down.

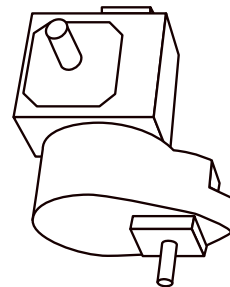
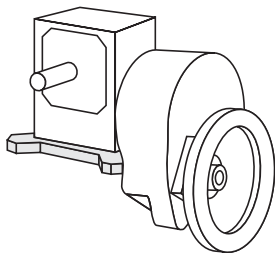

# Double Ended High Speed Shafts

Dimension — Inches

## Solid/Solid Size 1133-1325

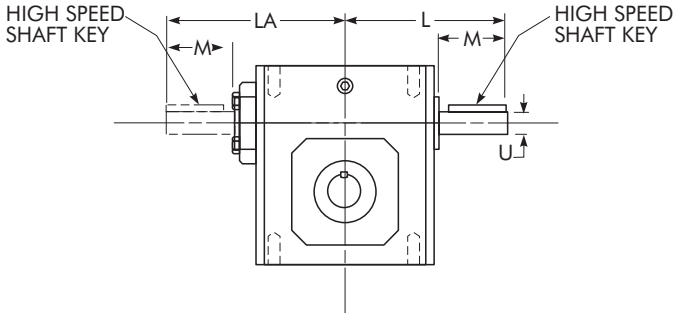

DRIVE	L	LA	M	U	Key
1133	3.82	4.37	1.76	.500	.1250 x 1.44
1154	4.35	4.90	1.76	.625	.1875 x 1.50
1175	4.45	5.00	1.76	.625	.1875 x 1.50
1206	4.82	5.37	1.76	.625	.1875 x 1.50
1238	5.51	6.15	2.38	.750	.1875 x 1.50
1262	6.07	6.72	2.38	.750	.1875 x 1.50
1300	6.57	7.22	2.38	.875	.1875 x 1.50
1325	6.76	7.40	2.38	.875	.1875 x 1.50

## Solid/Solid Size 1425-1525

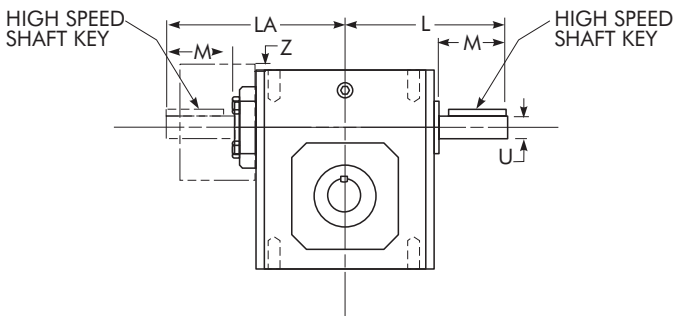

DRIVE	L	M	U	Key
1425	9.57	3.47	1.250	.2500 x 2.88
1525	10.88	3.38	1.250	.2500 x 3.00

## Solid/Solid Size 1600-11000

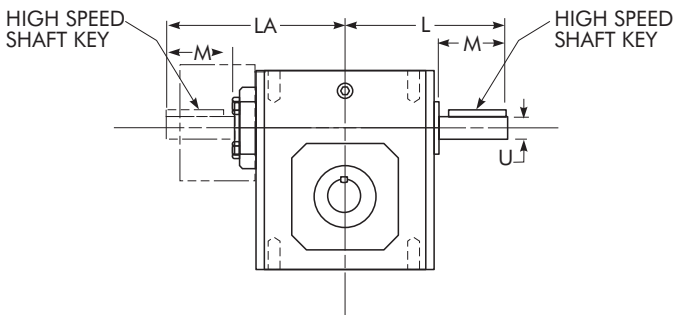

DRIVE	L	LA	M	MA	U	Key	Z
1600	11.78	14.55	3.41	3.41	1.500	.3750 x 3.00	.33
1700	11.50	13.88	2.97	2.51	1.625	.3750 x 2.81	.35
1800	12.50	15.50	2.84	2.98	1.875	.5000 x 2.81	.57
11000	15.50	18.82	3.76	4.13	2.250	.5000 x 3.69	.51

## Quill/Solid Size 1133-1600

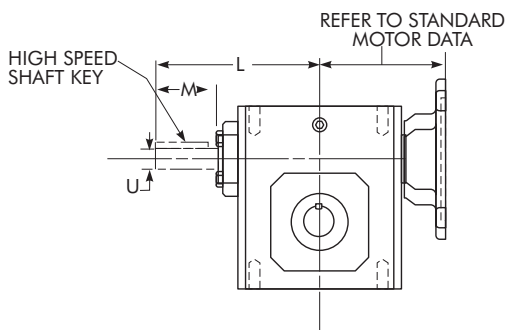

DRIVE	L	M	U	Key
1133	4.37	1.76	.500	.1250 x 1.44
1154	4.90	1.76	.625	.1875 x 1.50
1175	5.00	1.76	.625	.1875 x 1.50
1206	5.37	1.76	.625	.1875 x 1.50
1238	6.15	2.38	.750	.1875 x 1.50
1262	6.72	2.38	.750	.1875 x 1.50
1300	7.22	2.38	.875	.1875 x 1.50
1325	7.40	2.38	.875	.1875 x 1.50
1425	9.55	3.47	1.250	.2500 x 2.88
1525	10.88	3.39	1.250	.2500 x 3.00
1600	14.55	3.41	1.500	.3750 x 3.00

↔ Size 1600 comes standard with fan not shown.



**THIS PAGE INTENTIONALLY LEFT BLANK**

# World Class Customer Service

For more than 100 years, the dedicated people of Rexnord have delivered excellence in quality and service to our customers around the globe. Rexnord is a trusted name when it comes to providing skillfully engineered products that improve productivity and efficiency for industrial applications worldwide. We are committed to exceeding customer expectations in every area of our business: product design, application engineering, operations, and customer service.

Because of our customer focus, we are able to thoroughly understand the needs of your business and have the resources available to work closely with you to reduce maintenance costs, eliminate redundant inventories and prevent equipment down time.

Rexnord represents the most comprehensive portfolio of power transmission and conveying components in the world with the brands you know and trust.

Omnibox and Rexnord are registered trademarks of Rexnord Industries, LLC. Viton is a registered trademark of DuPont. Falk is a trademark of Rexnord. All rights reserved.

## WORLDWIDE CUSTOMER SERVICE

### AUSTRALIA

Rexnord Australia Pty. Ltd.  
Picton, New South Wales  
Phone: 61-2-4677-3811  
Fax: 61-2-4677-3812

### BRAZIL

Rexnord Correntes Ltda.  
Sao Leopoldo - RS  
Phone: 55-51-579-8022  
Fax: 55-51-579-8029

### CANADA

Rexnord Canada Ltd.  
Scarborough, Ontario  
Phone: 1-416-297-6868  
Fax: 1-416-297-6873

### CHINA

Rexnord China  
Shanghai, China  
Phone: 86-21-62701942  
Fax: 86-21-62701943

### EUROPE

Rexnord NV/SA  
Mechelen, Belgium  
Phone: 32-15-443811  
Fax: 32-15-443860

Rexnord Kette GmbH  
Betzdorf, Germany  
Phone: 49-2741-2840  
Fax: 49-2741-284-385

### LATIN AMERICA

Rexnord International, Inc.  
Milwaukee, Wisconsin  
Phone: 1-414-643-2366  
Fax: 1-414-643-3222  
E-mail: [international2@rexnord.com](mailto:international2@rexnord.com)

### MEXICO

Rexnord S.A. de C.V.  
Queretaro, Qro.  
Phone: 52-442-218.5000  
Fax: 52-.442-218-1090

### SINGAPORE

Rexnord International, Inc.  
Singapore City, Singapore  
Phone: 65-6338-5622  
Fax: 65-6338-5422

### UNITED STATES

Customer Service  
Phone: 1-866-REXNORD  
(1-866-739-6673)  
Fax: 1-614-675-1898  
E-mail: [rexnordcs\(state\)@rexnord.com](mailto:rexnordcs(state)@rexnord.com)  
Example: [rexnordcsohio@rexnord.com](mailto:rexnordcsohio@rexnord.com)

### ALL COUNTRIES NOT LISTED

Rexnord International  
Milwaukee, Wisconsin  
Phone: 1-414-643-2366  
Fax: 1-414-643-3222  
E-mail: [international1@rexnord.com](mailto:international1@rexnord.com)

